

Mechanical Seals Technical Manual

Garlock
SEALING TECHNOLOGIES®

an EnPro Industries company

INTRODUCTION

KLOZURE® is the leading manufacturer of bearing protection devices for the heavy duty industrial market. Our broad product line includes mechanical seals, radial lip seals and non-contact labyrinth bearing isolators.

KLOZURE® is a global company with installations worldwide, solving demanding applications big and small. We believe the best way to service the end user is through our strategic alliances with distribution partners. Our distribution partners are, ultimately, the quickest

way to constantly introduce new and innovative products at higher levels of performance and quality - products that will last longer and reduce overall maintenance costs.

With every KLOZURE® Seal, you can depend on receiving the backing of every KLOZURE® team member and their “can do” attitude, high-quality workmanship, and outstanding pride in a job done right. No matter what your difficult application may be, you can rest assured that KLOZURE® has a solution!

TECHNICAL MANUAL - HOW TO USE

The KLOZURE® Mechanical Seal Technical Manual is designed to facilitate product selection and to give you the most complete and relevant technical information you can find.

GARLOCK KLOZURE WARRANTY

All merchandise ordered shall be sold subject to SELLER'S standard warranty, viz: SELLER warrants that any product of its manufacture, which upon examination is found by a SELLER'S representative to be defective either in workmanship or material whereby it is not suitable under proper usage and service for the purpose for which designed, will be, at SELLER'S option, repaired or replaced free of charge including transportation charges but not cost of installation providing that SELLER receives written claim specifying the defect within one year after SELLER ships the product. ALL OTHER WARRANTIES EX-

PRESSED OR IMPLIED INCLUDING ANY WARRANTY OF MERCHANTABILITY ARE HEREBY DISCLAIMED. The foregoing expresses all of SELLER'S obligations and liabilities with respect to the quality of items furnished by it and it shall under no circumstances be liable for consequential damages.

Garlock
SEALING TECHNOLOGIES®

an EnPro Industries company

TABLE OF CONTENTS

Introduction	3
Mechanical Seal Types.....	7
Mechanical Seal Applications	11
Environmental Controls.....	15
KLOZURE® Mechanical Seal Styles	19
Component Seals	32
Appendix A - P/S-II for Viking Pumps	39
Appendix B - P/S-II for Blackmer Pumps	40
Appendix C - P/S-II for Tuthill Pumps	41
Appendix D - P/S-II for Desmi-Rotan Pumps	42
Appendix E-S - Dimensional Data.....	43
Glossary of Terms and Definitions	57
Damage Analysis and Troubleshooting	60
ROI Guidelines	68
Mechanical Seal Data Sheets	69
Surface Speed Chart	75

Introduction

Who Uses Mechanical Seals?

Everyone in the industrialized world uses mechanical seals. Various pieces of rotary or rotating equipment, pumps in particular, depend on mechanical seals to control leakage. Familiar rotary equipment devices include automobile water pumps, washing machines, dish washers, compressors, swimming pool pumps and farm service pumps. Mechanical seals are used anywhere that liquid and gases are transferred by rotating equipment.

Pumps are one of the most widely sold pieces of equipment in industry, second only to electric motors. Pumps are found in all industries, large buildings and households, farming operations, mining, construction and city services. Although some of the small, inexpensive pumps are disposable (i.e. automotive water pumps), most pumps require packing or mechanical seals to control leakage between the rotating elements and stationary housings. These packings and seals must be serviced to insure controlled leakage is maintained.

Maintenance of pumping systems is what we will focus on in the following sections. We will learn that some products are allowed to drip without concern, while others must not leak more than a few parts per million (PPM) and need to be monitored closely with electronic detection devices.

How Pumps Work

All rotary pumping systems (Fig. 1) contain a drive system. The driver is what makes the pump rotate. There are several types of drivers (i.e. electric motor, combustion engine or steam turbines, etc.). Often, but not always, pumping systems contain a coupling, which attaches the driver to the rotary shaft of the pump. A bearing arrangement supports the shaft. The bearings may be any of several types (i.e. sleeve bushings, ball, roller, etc.) Normally, there are two bearings that support the shaft (thrust bearing and radial bearing). Attached to the shaft is the impeller. A volute shrouds the impeller. Within the volute, the rotation of the impeller increases media velocity and pressure. The media being transported enters the pump through the suction inlet and exits the volute through the discharge outlet at a greater pressure and velocity. The rotating element extends through the stationary housing of the pump in which some type of sealing device has been or can be installed. This housing or cavity is known as the stuffing box for packing or seal chamber for mechanical seal applications.

Although somewhat simplified (there are all types of service variations and designs, some of which may contradict this description), the above can be considered a general description of how most rotary pumps function.

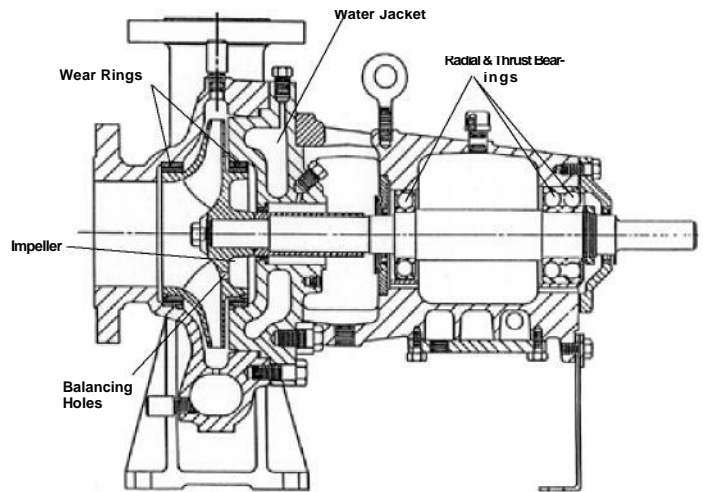

Figure 1 - Typical high pressure, high temperature process pump

Mechanical Seals vs. Packing

Although mechanical seals had been around for many decades, by 1955 industry had converted only a small percentage of pumps from packing to mechanical seals. This is due to various reasons:

- To install a seal, the pump would have to be taken off-line and disassembled.
- Packing could be installed quickly, or an extra ring added, without disassembly.
- Packing was, and is still thought to be, cheaper.
- Maintenance people were not informed/educated about mechanical seals and felt more comfortable with packing.
- Plant personnel gave little thought to the cost of product loss, energy, housekeeping, etc., because it had always been sealed the same way.
- There were few guidelines that dictated leakage control and few people seriously considered its dramatic cost.

Since Congress passed the Clean Air Act in 1955, and amended it in 1970, federal, state and local regulations have become increasingly strict regarding emissions control. Some regulation requirements are at the brink of or beyond current technology. These regulations have created an atmosphere where, in many cases, it is no longer an option for industry to make the packing choice.

Emissions Regulations

Today, mechanical seals are required by law to control emissions of many products. There is currently a list of 189 substances regulated by the Environmental Protection Agency as toxins under Section 112 of the Clean Air Act (Figure 2), and this list will continue to grow.

EPA Regulations forcing compliance has obligated industries to demand better seals from manufacturers which in turn, has made us do a better job. Industries' need for more efficient sealing systems has compelled seal companies to design seals that do not damage equipment, handle higher pressure or vacuum, provide a wide range of environmental control options and are able to seal a wider range of chemicals. In addition, these sealing units are more user friendly. Today, the seals industries used twenty years ago are being out-classed in every category by newer designs.

When handling volatile organic compounds (VOC), seal selection is often determined by specific gravity and maximum allowable emission levels. Lower specific gravity products, combined with parts per million VOC emissions allowable, dictate not only if a mechanical seal is required, but also if double mechanical seals are required. Federal law dictates that these emissions must be contained. Any VOC that has a specific gravity of 0.4 or less, requires a double mechanical seal (Figure 3).

These are the 189 substances to be regulated by the EPA as toxics under section 112 of the Clean Air Act. If you have any of these, we can help.

Acetaldehyde	3,3-Dichlorobenzidine	Methoxychlor	Titanium tetrachloride
Acetamide	Dichloroethyl ether	Methyl bromide(Bromomethane)	Toluene
Acetonitrile	(Bis(2-chloroethyl)ether)	Methyl chloride (Chloromethane)	2,4-Toluene diamine
Acetophenone	1,3-Dichloropropene	Methyl chloroform	2,4-Toluene diisocyanate
2-Acetylaminofluorene	Dichlorvos	(1,1,1-Trichloroethane)	o-Toluidine
Acrolein	Diethanolamine	Methyl ethyl ketone (2-Butanone)	Toxaphene (chlorinated camphene)
Acrylamide	N,N-Diethyl aniline	Methyl hydrazine	1,2,4-Trichlorobenzene
Acrylic acid	(N,N-Dimethylaniline)	Methyl iodide (Iodomethane)	1,1,2-Trichloroethane
Acrylonitrile	Diethyl sulfate	Methyl isobutyl ketone (Hexone)	Trichloroethylene
Allyl chloride	3,3-Dimethoxybenzidine	Methyl isocyanate	2,4,5-Trichlorophenol
4-Aminodiphenyl	Dimethyl aminozobenzene	Methyl methacrylate	2,4,6-Trichlorophenol
Aniline	3,3-Dimethyl benzidine	Methyl tert butyl ether	Triethylamine
o-Anisidine	Dimethyl carbamoyl chloride	4,4-Methylene bis(2-chloroaniline)	Trifluralin
Asbestos	Dimethyl formamide	Methylene chloride	2,2,4-Trimethylpentane
Benzene (including benzene from gasoline)	1,1-Dimethyl hydrazine	(Dichloromethane)	Vinyl acetate
Benzidine	Dimethyl phthalate	Methylene diphenyl diisocyanate (MDI)	Vinyl bromide
Benzotrifluoride	4,6-Dinitro-o-cresol, and salts	4,4-Methylenedianiline	Vinyl chloride
Benzyl chloride	2,4-Dinitrophenol	Naphthalene	Vinylidene chloride
Biphenyl	2,4-Dinitrotoluene	Nitrobenzene	(1,1-Dichloroethylene)
Bis(2-ethylhexyl) phthalate(DEHP)	1,4-Dioxane(1,4-Diethyleneoxide)	4-Nitrobiphenyl	Xylenes (isomers and mixture)
Bis(chloromethyl)ether	1,2-Diphenylhydrazine	4-Nitrophenol	o-Xylenes
Bromofom	Epichlorohydrin(1-Chloro-2,3-epoxypropene)	2-Nitropropane	m-Xylenes
1,3-Butadiene	1,2-Epoxybutane	N-Nitroso-N-methylurea	p-Xylenes
Calcium cyanamide	Ethyl acrylate	N-Nitrosodimethylamine	
Caprolactam	Ethyl benzene	N-Nitrosomorpholine	
Captan	Ethyl carbamate (Urethane)	Parathion	Antimony Compounds
Carbaryl	Ethyl chloride (Chloroethane)	Pentachloronitrobenzene (Quintobenzene)	Arsenic Compounds (inorganic including arsenic)
Carbon disulfide	Ethylene dibromide (Dibromoethane)	Pentachlorophenol	Beryllium Compounds
Carbon tetrachloride	Ethylene dichloride (1,2-Dichloroethane)	Phenol	Cadmium Compounds
Carbonyl sulfide	Ethylene glycol	p-Phenylenediamine	Chromium Compounds
Catechol	Ethylene imine (Aziridine)	Phosgene	Cobalt Compounds
Chloramben	Ethylene oxide	Phosphine	Coke Oven Emissions
Chlordane	Ethylene thiourea	Phosphorus	Cyanide Compounds ¹
Chlorine	Ethylidene chloride (1,1-Dichloroethane)	Phthalic anhydride	Glycol ethers ²
Chloroacetic acid	Formaldehyde	Polychlorinated biphenyls (Aroclors)	Lead Compounds
2-Chloroacetophenone	Heptachlor	1,3-Propane sultone	Manganese Compounds
Chlorobenzene	Hexachlorobenzene	beta-Propiolactone	Mercury Compounds
Chlorobenzilate	Hexachlorobutadiene	Propionaldehyde	Fine mineral fibers ³
Chloroform	Hexachlorocyclopentadiene	Propoxur (Baygon)	Nickel Compounds
Chloromethyl methyl ether	Hexachloroethane	Propylene dichloride (1,2-Dichloropropane)	Polycyclic Organic Matter ⁴
Chloroprene	Hexamethylene-1,6-diisocyanate	Propylene oxide	Radionuclides (including radon) ⁵
Cresols/Cresylic acid (isomers and mixture)	Hexamethyl phosphoramide	1,2-Propylenimine (2-Methyl aziridine)	Selenium Compounds
o-Cresol	Hexane	Quinoline	
m-Cresol	Hydrazine	Quinone	
p-Cresol	Hydrochloric acid	Styrene	
Cumene	Hydrogen fluoride(Hydrofluoric acid)	Styrene oxide	
2,4-D, salts and esters	Hydroquinone	2,3,7,8-Tetrachlorodibenzo-p-dioxin	
DDE	Isophorone	1,1,2,2-Tetrachloroethane	
Diazomethane	Lindane (all isomers)	Tetrachloroethylene (Perchloroethylene)	
Dibenzofurans	Maleic acylhydride		
1,2-Dibromo-3-chloropropane	Methanol		
Dibutylphthalate			
1,4-Dichlorobenzene(p)			

Figure 2

Seal Selection Can Be Based on the Fluid's Specific Gravity and the Maximum Allowable VOC Emission Levels

Size: < 6 in. (152 mm)
 Pressure: < 600 psig (40 bar)
 Speed: < 3,600 rpm

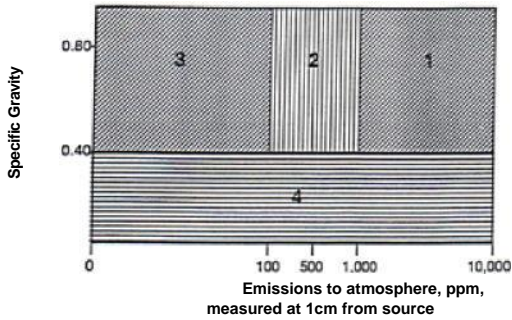

Chart Area	Acceptable Technology
1	Single, double or tandem seals are acceptable
2	Single seals may be acceptable depending on actual operating conditions, seal size, pressure, and temperature, tandem or double seals may be required to meet emission regulations
3	Tandem or double seals are acceptable
4	Double seals are required

Figure 3

Product Loss

Often, after a decision has been made to change from packing to a mechanical seal, a noticeable amount of product is saved. Almost without exception, the product savings alone will pay for all of the costs associated with the conversion. Typically product savings will pay for the mechanical seal many times over.

By taking a volume sample of leakage from a packed pump, measured in time, it is simple to calculate the amount of lost product each day. The next step is to multiply volume times the cost per unit and the number of pumps to find the astonishing cost of lost product when the numbers are calculated on a yearly basis (Figure 4). By using these calculations alone, most plants have realized the value of mechanical seals over compression packing.

	One Drop Per Second	Three Drops Per Second
1 Minute Loss	1/12 ουγγε	2 ουγγε
1 Hour Loss	6 ουγγε	12 ουγγε
Day Loss	1 γαλλον	3 γαλλον
Week Loss	8 γαλλον	24 γαλλον
Month Loss	34 γαλλον	102 γαλλον
	1/16" (1.6 mm)	3/16" (4.8 mm)
1 Minute Loss	7 ουγγε	21 ουγγε
1 Hour Loss	42 ουγγε	126 ουγγε
Day Loss	252 ουγγε	756 ουγγε
Week Loss	1764 ουγγε	5292 ουγγε
Month Loss	72 ουγγε	216 ουγγε
	1/4" (6.3 mm)	
1 Minute Loss	33 ουγγε	
1 Hour Loss	198 ουγγε	
Day Loss	1188 ουγγε	
Week Loss	8316 ουγγε	
Month Loss	3468 ουγγε	

Figure 4

Energy Cost

The amount of electricity it takes to drive a mechanical seal is dramatically less than what it takes to drive a pump with compression packing (see sample energy cost calculation, Figure 5). Add the cost of flush, if applicable (support systems).

Packing compresses against the shaft while controlling leakage, and requires more energy to drive the pump. The number of packing rings per set (4, 5 or 6 rings) increases the amount of energy required.

A single mechanical seal only has two very flat, very low friction/hydroplaning faces pressed together that must be driven. So, the resistance generated by a mechanical seal is dramatically less than a set of several packing rings and the energy/cost savings are significant.

A study was designed as follows:

1. Fifteen pumps were used, all powered by 100 horsepower Westinghouse electric motors.
2. Each style of packing was tested for three weeks.
3. The Bingham pumps all had a rated efficiency by the manufacturer based upon certain media at a certain specific quantity. They then installed mechanical seals.

Power Cost \$0.611 KW per hour \$1.460 KW per day \$525.60 KW per year			
Type of Packing	Additional H.P. Required	Additional KW Required	Cost/ Pump/ Year
TFE Asbestos	6.00	4.400	\$2,312.00
Synthepak Fiber #1	5.50	4.004	\$2,104.00
Synthepak #2	5.00	3.652	\$1,919.00
Carbon PTFE	4.50	3.300	\$1,734.00
Carbon	3.00	2.200	\$1,156.00
Graphite	2.00	1.452	\$763.00
Single Mechanical Seal	0.33	0.242	\$127.20
Power Cost based on:		Southwest Electric Power Company Texas Gas Utilities Company Texas Power & Light Company	

Figure 5

The results (Figure 5) show that a Pump with PTFE asbestos in the stuffing box and a 100 horsepower Westinghouse electric motor, operating 24 hours per day, 365 days per year, would total \$2,312^{*} per year in electric costs. The same pump operating with Graphite would cost \$773^{*}, a savings of \$1,539 per year. This study clearly shows that the “price” of the packing and “cost” of its use are two entirely different factors.

^{*}Note: These figures are the electric costs to drive the packing only. Electric costs to run the motor are not included.

In Figure 6 we see an example of calculations showing where savings are available by changing from packing to a mechanical seal. The example used is a standard paper stock pump, using cold (50°F) water for flush media. The rate of flush is two (2) gallons per minute (1,051,200 gallons per year). The flush water must be elevated from 50°F to 140°F for the system to function properly.

Energy Cost Packing flush water	
Power Cost	120 gal/hr @ 50°F
Seal flush water	2 gal/hr @ 50°F
Paper stock operating temperature	140°F
Cost of Energy	\$2.00/1,000,000 BTU

Based on this data, the following calculations apply:
 1 BTU = 1lb of water raised 1°F
 1 gal water = 8.34 lbs
 Temperature differential 140°F - 50°F = 90°F
 8.34x90 = 750 BTU's/gal raised 90°F

Packing cost calculation:

$$\frac{750\text{BTU's}}{\text{Gal}} \times \frac{120\text{ Gal}}{\text{hr}} \times \frac{24\text{ hrs}}{\text{day}} \times \frac{365\text{ days}}{\text{year}} \times \frac{\$2.00}{1,000,000\text{ BTU}} = 1,576.80$$

Seal cost calculation:

$$\frac{750\text{BTU's}}{\text{Gal}} \times \frac{2\text{ Gal}}{\text{hr}} \times \frac{24\text{ hrs}}{\text{day}} \times \frac{365\text{ days}}{\text{year}} \times \frac{\$2.00}{1,000,000\text{ BTU}} = 26.26$$

Figure 6

The chart in Figure 6 shows the estimated cost in British Thermal Unit dollars per year, to raise the flush water (50°F) to system temperature (140°F). This example does not address power for flush water transfer, evaporation costs or waste treatment.

A mechanical seal can run leak free with as little as two (2) gallons per hour flushing or 17,520 gallons of water per year. This could amount to a savings of 1,033,680 gallons of water per year, per pump. Even if the flush water volume was tripled on the mechanical seal, the savings would remain dramatic (998,640 gallons per year per pump).

Average Annual Cost of Packed Pumps

As an example of the operational costs using typical pumps in industry, we have chosen two paper mill applications and attached the cost study information (See Figure 7). This article is sourced from a December 1983 issue of Pulp and Paper magazine.

As you can see the cost of maintaining a packed pump is very expensive. The mechanical seal approach can save much of these costs by reducing the following:

- Eliminating or reducing flush volume
- Fewer bearing changes
- Newer seal designs eliminate need to change pump sleeves
- Reduce labor costs
- Dramatically reduce housekeeping
- Virtually stop product loss

Average Annual Cost of Packed Pumps for:

A. Titanium Dioxide Pump (30% solids)
 B. Paper Stock Pump (1.5% to 5% consistency)

	A	B
Effluent Treatment	\$50	\$2,100
Bearing Frame Rebuild	\$650	\$850
Packing Cost (Material)	\$75	\$100
Sleeve Cost	\$250	\$350
Seal Water	\$200	\$550
Product Loss	\$15,000	\$500
Millwright Labor	\$1,000	\$1,000
Housekeeping Labor	\$500	\$500
Oiler Labor	\$500	(\$500)
Totals	\$18,225	\$6,450

Note: INFORMATION TAKEN FROM PULP & PAPER, DECEMBER 1983 ISSUE, PAGE 68. Article written by Bruce Hoffenbecker Senior Maintenance Engineer Weyerhaeuser Co, Rothschild, WI.

Figure 7

Return on Investment

When one has interest in calculating the return on investment when changing from packing to mechanical seals, the form in Figure 8 is useful. Always work directly with the people in the plant who are interested in accurate numbers. Plant personnel must be included at every step, while collecting the cost for each line. This must be done because the final cost, versus savings, will be so dramatic that accuracy will otherwise be questioned. However, if you can run a mechanical seal for one year, with no maintenance, product loss, bearing change and no new sleeve, while using less energy and lower flush volume, the money saved is always dramatic (multiplied by the number of pumps converted). This approach can also be utilized to measure the savings when converting from one style of mechanical seal to another.

NOTE: Dollars saved in the maintenance department reflect on profits more dramatically than the same dollar amount in Sales. They are bottom line profit dollars.

Mechanical Seal Types

Face Seals

All face-type mechanical seals consist of a primary seal, secondary seal, and mechanical loading device. Mechanical seals must have two (2) flat faces that when pressed together form the primary seal. The flatness of these faces is the most precision-critical characteristic of any mechanical seal. Flatness is measured in helium light bands. One light band is 0.0000116" (0.000294mm). One of the two faces rotates (rotary) with the pump shaft and the other face does not rotate (stationary).

All face seals require a secondary seal, which can be some type of elastomeric compound or gasket material. The secondary seal closes leak paths between the rotary face and the shaft as well as between the housing/gland and the stationary face.

Because seal faces wear against each other and all pumps vibrate, requiring flexible seals, a mechanical loading device is needed to insure continuous face contact, even when the pump is shut off. The mechanical loading device is normally some type of spring(s) or metal bellows.

As the faces rub together, one rotating and one stationary, they operate with a fluid film migration between the faces to cool and lubricate (The faces hydroplane on this fluid film). Ideally the product being pumped will weep between the faces, entering as a liquid and remaining until vaporizing as it reaches atmosphere. The leakage that flows to the atmospheric side should not be visible. It must be understood that all mechanical seals leak some trace amounts of vapor.

Inside Seals

An inside seal (Figure 8) is mechanically designed in such a way that the rotary portion of the mechanical seal, when installed, is located inside the pump seal chamber.

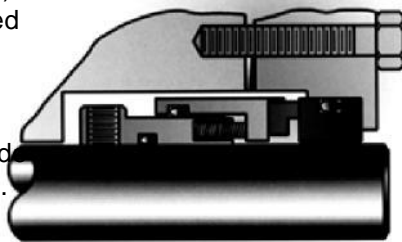

Figure 8

When using an inside mechanical seal, the fluid and pressure are on the outside diameter (O.D.) of the seal. The fluid pressure acts as a hydraulic closing force, and typically inside seals can be used in higher pressure applications than outside seals. Centrifugal force acts to expel solids away from the rotary and helps retard the flow/migration of liquid across the faces. The metal parts are in contact with the product being pumped, which must be compatible when sealing aggressive chemicals.

Outside Seals

An outside seal (Figure 9) is a mechanical seal designed in such a way that the rotary portion of the mechanical seal is located outside the pump seal chamber.

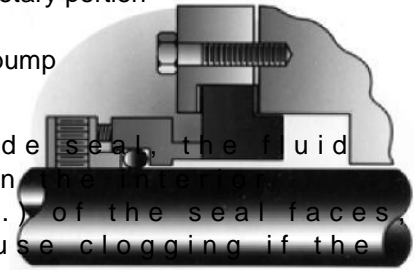

Figure 9

With an outside seal, the fluid pressure is on the inside diameter (I.D.) of the seal faces, which can cause clogging if the media contains solids.

With some outside designs, the product pressure can overcome the spring load. Centrifugal force acts to increase flow/migration of lubricating fluid across the seal faces which, combined with pressure, limits the outside seal's service pressure to 150 psi (FSA recommendation).

Set screw or clamp ring drives are options with some outside seals. Typically, outside seals are used for chemical service in non-metallic pumps, where set screws do not work well (too hard, or non metallic shafts). The fluid being pumped does not come in contact with the metal parts of the seal, which often eliminates the need for expensive and/or exotic metals.

Rotary Seals

A rotary seal (Figure 10) is a mechanical seal designed so the spring(s) or mechanical loading device rotates with the pump shaft.

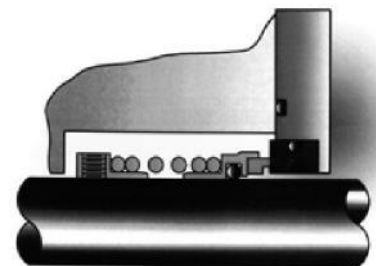

Figure 10

At high speed, the spring(s) can distort and their effectiveness is reduced. Also, rotary seal springs adjust for any misalignment, twice per revolution (3500 times per minute on a pump at 1750 rpm), which can cause fatigue and spring breakage. Rotary seals tend to expel solids away from the seal as it spins.

Pusher Seals

A pusher seal is a seal design that pushes a dynamic-secondary seal (o-ring, wedge, chevron, u-seal, etc.) along the shaft to compensate for face wear and/or shaft movement. As a result, a pusher seal will wear a groove in the shaft/sleeve surface. The area of wear created by the secondary seal is called a fret.

Stationary Seals

A stationary seal (Figure 11) is a mechanical seal designed in such a way that the spring(s) do not rotate with the pump shaft, but remain stationary. Because the springs do not rotate, they are unaffected by the pump speed.

The springs do not correct or adjust for each rotation. They adjust for misalignment only once, when installed, and are much less subject to fatigue or breaking. Stationary seals are preferred for high-speed service.

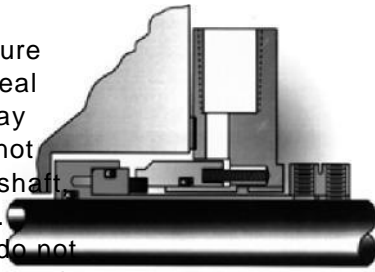

Figure 11

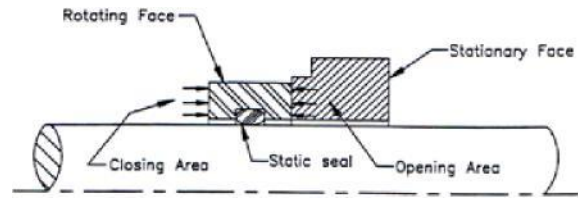

Figure 13a

Balanced Seals

A balanced seal (Figure 13b) is a mechanical seal geometrically designed in such a way that the hydraulic pressure, which acts to close the seal faces, is substantially reduced. The closing area, affected by hydraulic pressure, is reduced in comparison to the opening or neutralized area, which is also affected by hydraulic pressure.

Balanced seals generate less heat because of the reduced pressure forcing the faces together, hence they are designed to handle much higher pressure.

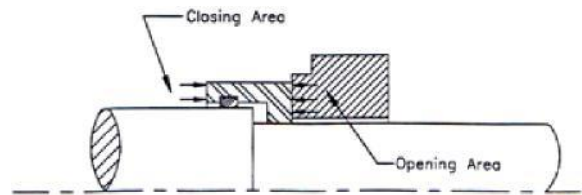

Figure 13b

Non-Pusher Seals

A non-pusher seal (Figure 12a) is a mechanical seal designed in a way that eliminates the dynamic secondary seal.

Normally, non-pusher seals are metal bellows or elastomeric bellow seals.

They cause no damage to the shaft, from a secondary seal's axial movement. They flex at the bellows.

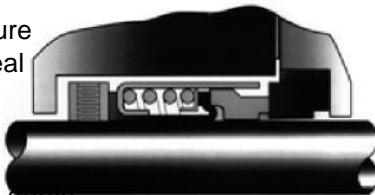

Figure 12a

Metal Bellows Seals

A metal bellows seal (Figure 12b) is a mechanical seal with a body made of several metal plates welded together, which act as a mechanical loading device (spring), and with the bellows also acting as a secondary seal (The bellows is dynamic and fluid

can not pass through it). The elastomeric secondary seal in a metal bellows driver is static (acts like a gasket) and does not damage the shaft. Metal bellows seals are always balanced, by design.

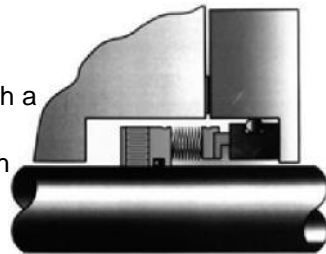
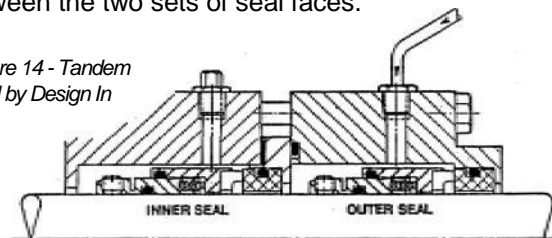

Figure 12b

Double Seals

A double seal (Figures 14, 15a & b) is an arrangement in which two (2) mechanical seals are utilized face to face, back to back or in tandem (facing the same direction), allowing a barrier/buffer fluid or gas to be introduced between the two sets of seal faces.

Figure 14 - Tandem Seal by Design In Line



Unbalanced Seals

Unbalanced seals (Figure 13a) are mechanical seals designed so that the full hydraulic pressure of the seal chamber acts to close the mechanical seal faces, without any proportion of that pressure being reduced or hydraulically balanced through the geometric design of the seal. Unbalanced seals are for use in low-pressure applications only (FSA recommends 50 psi (3.5 bar) service or less).

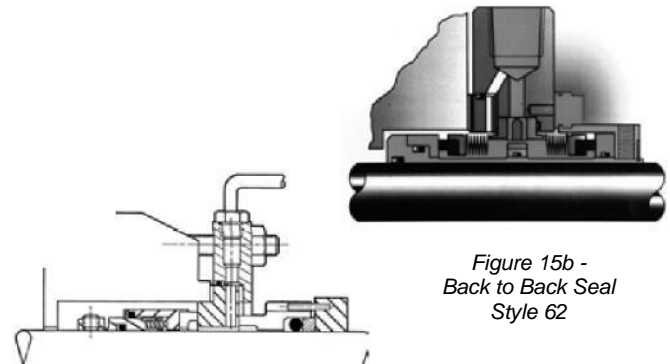

Figure 15b - Back to Back Seal Style 62

Figure 15a - Double In Line Seal

Face Seals

P/S®-I Seal Technology

Lip seals offer an alternative to face seals and packing for many applications, particularly those viscous, temperature-sensitive, salting, crystallizing products that drive face seal users crazy. As an alternative to face seals, Garlock FLUIDTEC® developed the P/S® thermal-plastic high performance lip seal. The P/S® seal can also be used to augment the service life of both packing and seals.

Because it is a lip seal, the P/S® seal has no moving parts to clog. It possesses good chemical resistance and high temperature (to 400°F (204°C) when used as a gasket and 300°F (149°C) for dynamic applications) and pressure performance (as high as 150 psi (10 bar) when properly backed).

A proprietary formulation developed by Garlock, GYLON® is a restructured PTFE compound that is available in eight different styles. From this family of GYLON® products have evolved two (2) thermal-plastic compounds used for the P/S® seal elements: Black (Graphite filled) and White (Food Grade) GYLON®. The P/S® GYLON® sealing elements have characteristics of memory behavior, elasticity, low friction and require no mechanical load to seal.

Because different applications demand different degrees of versatility, the P/S® seal has been engineered into various configurations (see Figure 16):

- Standard Configuration
- Reverse Lip (sealing element)
- Double Lip or Tandem (same direction)
- Double Opposing Lip (sealing elements)

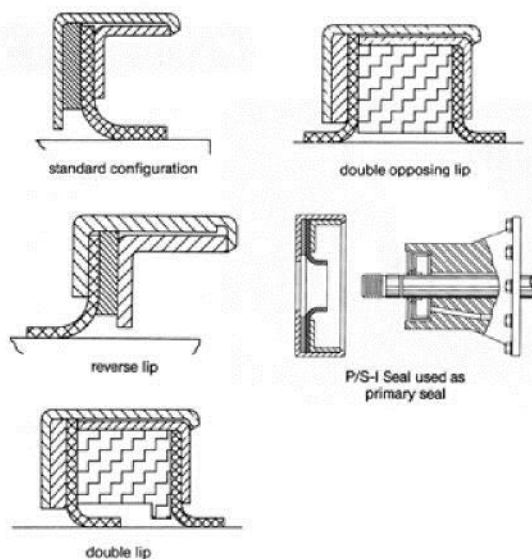

Note: See P/S®-I & P/S®-II engineering brochure for additional performance and installation data

Figure 16

P/S® sealing elements are formed to the size required, but not molded. As a result, expensive dies are not required. This allows for versatility when manufacturing special sizes.

P/S®-I Seal

Typical applications (see Figure 17):

- Product excluder with compression packing
- Restriction/excluder with a mechanical seal
- Primary seal
- Pressure and vacuum service (double opposing lips)
- Pressure with backup (double lip, tandem)

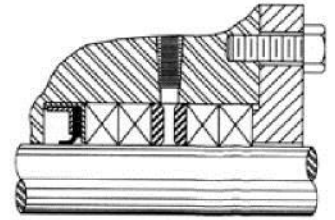

P/S®-I Seal used as product excluder with compression packing

Figure 17

P/S®-II Cartridge Multi-Lip Seal

Typical applications (see Figure 18):

- Positive displacement pumps
- Progressive cavity pumps
- Centrifugal pumps
- Rotary valves

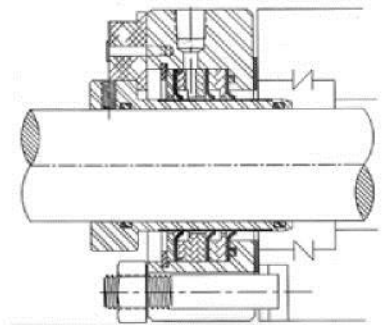

Figure 18

Typical Products Sealed by P/S®-II Seals

- Asphalt
- Fuel oil
- Glues
- Hot wax
- Raw bubble gum
- Resins
- Raw fiber glass
- Fruit pulp and seeds
- Caustic soda
- Surfactants
- Ammonia
- Chemical waste
- Soap and soap powder
- Black liquor
- Polymers
- Automotive under coating

P/S® Seals Performance Guidelines

Pressure: To 150 psig (10 bar) with positive backup to seal case.

Vacuum: To 0.054 inches of water (0.004 in. of Hg) with element facing vacuum source. Full vacuum when element is facing away from vacuum source.

Temperature: To 300°F (150°C)
Over 300°F (150°C), consult engineering

Surface Speed: 700 fpm dry running, 1800 fpm with proper environmental controls. (Consult engineering)

Runout: 0.005" TIR

Axial End Play: Not affected

Materials

Metal Parts: 316SS (other materials optional)

Set Screws: Hastelloy C*

O-Rings: Viton** Standard (other materials optional)

Sealing Surface Requirements

Shaft Finish: 4 to 6 Micro inches (0.10 to 0.15 micrometers)

Shaft Hardness: 50 to 70 Rockwell C

Bore Finish: 100 Micro inches (2.54 micrometers) or smoother

Sizes

Standard: 5/8" to 7" diameter shaft from standard production (smaller and larger sizes available)

Single element standard on P/S®-I;
multiple element designs on P/S®-II

For special applications, consult Garlock Applications Engineering.

Figure 19

P/S® Seals Limitations

P/S® technology is sensitive to radial shaft movement. It is recommended that no more than 0.005" of radial shaft movement be tested (see Figure 20).

* Hastelloy C is a registered trademark of Haynes International

** Viton is a registered trademark of DuPont Dow Elastomers

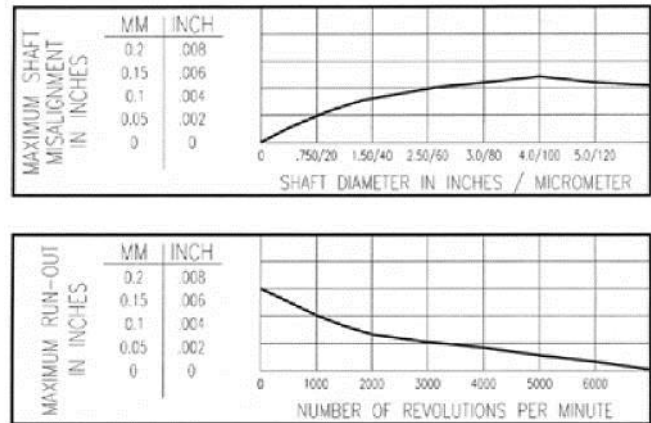

Figure 20

Note: P/S® sealing elements are not recommended for abrasive applications.

P/S® Cartridge Seal Installation Instructions

1. Place the seal onto the shaft
2. Assemble the pump equipment. Use flat washers under the gland nuts and lightly snug the gland to the face of the seal chamber.
3. Insure that the sleeve/drive collar is pressed forward and nested against the clip wings.
4. Check to insure all clips are positioned at 90° to the shaft, providing absolute centering of the drive collar.
5. Run each set screw in until it just touches the shaft. Tighten each set screw on the second rotation or cross torque. This will avoid pulling the sleeve off-center.
6. Insure that the clips are at 90° to the shaft and while rotating the shaft (by hand) insure that the drive collar is not rubbing or binding against one or two of the centering clips more than the rest. Use 0.001" or 0.002" feeler gage and test the gap between the clips and drive collar.

Note: The feeler gage should not pass between the clip(s) and the drive collar at any location. If it appears that a clip or two are tipped away from the drive collar, it indicates that the gland bolting is uneven. Tighten the bolt(s) on the opposite side from the tilted clip/gap and watch as the clip squares to the drive collar shoulder.

7. If an adjustment is required, loosen the gland nuts and move the gland slightly to achieve centering and re-tighten (gland nuts).
8. Repeat the process until you are satisfied the seal/shaft is centered.
9. Evenly tighten the gland nuts (cross torque).
10. Rotate the centering clips 90° and install environmental controls or plug the flush ports.

Mechanical Seal Application

These four steps must be taken with every application.

1. Choose materials that are chemically compatible with the product and will handle the temperature requirements and consistency (slurry, viscous, low specific gravity, etc.).
2. Choose the design/style, which is appropriate in size, to fit the equipment and engineered to handle the product.
3. Install the seal properly into a piece of equipment that is in good mechanical condition.
4. Apply environmental controls that will provide the best possible environment for the seal.

You may have the best design, installed properly in good equipment with the very best environmental controls, but if the gasket you choose is not compatible, it will leak and this will demonstrate that the job was not done properly.

Material Compatibility

Chemicals that Affect Chemical Grade Carbon

Most carbon grades should not be used in the presence of strong oxidizing agents. Following is a list of common chemicals that affect chemical grade carbon.

- *Aqua Regia* - nitric acid and hydrochloric acid, used for dissolving metals.
- *Calcium Chlorate* - greater than 5%, used in photography and pyrotechnics.
- *Chloric Acid* - at 200°F (93°C) and over 10% concentration will ignite organic materials on contact.
- *Chlorous Acid* - 200°F (93°C) greater than 10% concentration.
- *Ferric Chloride* - in excess of 200°F (93°C) and greater than 50% concentration.
- *Fluorine* - rocket fuel oxidizer.
- *Hydrofluoric Acid* - over 200°F (93°C) at 40% concentration or more. Used in pickling, etching, cleaning stone and brick, dissolving ore, cleaning castings, fermentation and purification.
- *Iodine* - 200°F (93°C) with 5% or more concentration, used in soap, dyes, salt, medicine and lubrication.
- *Nitric Acid* - 250°F (121°C) and 20% or more concentration, used in fertilizer, dyeing, explosives, drugs and etching.
- *Oleum or fuming sulfuric acid* - used to manufacture detergent and explosives.
- *Perchloric Acid* - used in making esters, explosives and medicine.

- *Sulfuric Acid* - 75% at 250°F (121°C) or more, most widely used of all chemicals.
- *Sodium Chlorate* - 5% or more concentration, used as bleach in paper processing, textiles, medicine and tanning leather.
- *Sodium Peroxide* - used in dyeing, paper bleaching and oxygen generation.
- *Sodium Hypochlorite* - 5% or more, used in paper pulp bleaching process and water purification.
- *Sulfur Trioxide* - used to manufacture sulfuric acid.

Chemicals that Abrade Carbon

The following liquids cause abrasive wear to carbon face material when carbon is used as a mechanical seal face.

- Chromic Acid
- Chromic Oxide (Aqueous)
- Chrome Plating Solutions
- Potassium Dichromate (Aqueous)
- Sodium Chromate
- Sodium Dichromate

Chloride Stress Corrosion

Chloride stress corrosion is a condition that causes cracks in stainless steel, when subjected to the following:

- Tensile Stress (Near yield point)
- Temperature (above 140°F (60°C))
- Chlorides

There are two (2) types of stress, tensile and compression. We, in the mechanical seal world, are interested in tensile stress because it acts to stretch or open the metal surface at the point of stress. Weak spots are first formed as small pits, followed by cracks. As temperature and stress are increased the cracking process is accelerated.

Chlorides, second only to water, are the most common substances in industry. Our only concern about our mechanical seal parts and chloride stress corrosion is the spring and/or metal bellows material. One should always resist using stainless steel springs or bellows, unless they are not in contact with chlorides. This is why Garlock Kloxure's standard spring material is Hastelloy C.

There is a much longer scientific explanation for the electrochemical process having to do with the action of chloride ions being destroyed and the formation of micro-anodes, etc. Our primary concern here is chloride stress corrosion. When stainless steel is subjected to heat, stress and chlorides, cracked springs or bellows are the common results.

Products that Change State

Almost any product changes state and, when considering seal design and environmental controls, we must anticipate the conditions that will occur (i.e. water will turn to steam at a given temperature and pressure). Following is a list of products that can change state dramatically with atmospheric contact or change in temperature. This is not intended to be a complete list.

Corrosive Acids and Bases

Corrosives often become twice as aggressive with as little as a 15 F (9 C) increase in temperature.

- Try to cool the seal by using a double seal with cool barrier/buffer fluid.
- Quench and drain or flush with cool product.
- Use a seal designed for chemical service.

Cryogenics

Liquid oxygen and nitrogen tend to freeze elastomers and moisture from atmosphere outboard.

- Use a double seal with buffer fluid between the product and atmosphere.
- Use a quench and drain to keep atmosphere isolated from the faces and prevent freezing.

Crystallization

Products that crystallize include sugar, caustics, brine, etc. These kinds of products tend to clog seals on the atmospheric side of seals. Clogging occurs when the product passes across the faces and moisture vaporizes, leaving a crystallized residue on the atmospheric side of the seal faces. Over time the crystals will continue to build up and restrict the seal's ability to adjust for movement, stalling O-rings and clogging springs or bellows. Crystals formed between seal faces are very abrasive and can cause abrasion of the faces.

- Use a quench and drain to control temperature and clean the debris from the atmospheric side of the seal.
- Use a double seal with barrier fluid to control the temperature and insulate/isolate atmosphere from the product.

Dangerous Products

These products include carcinogens, explosives, radiation, toxins and other lethal products, which are hazardous to plant workers and the environment, where leakage can not be tolerated. Even if the seal fails, fumes and liquid must be contained.

- Use a double seal as a tandem and provide containment for liquids and vapor recovery system (i.e. convection system).

Dry Running

Compressors, gases and vacuum service—seals that run in these applications require cooling to protect faces and elastomers from over heating.

- Use a double seal with good lubrication and compatibility characteristics. Also, pressurize the barrier fluid at least one atmosphere (15 psi (1 bar)) greater than seal chamber pressure.

Dry Solids

Cake mix, granulated soap, powder, etc., clog seals and cause excessive heat at elevated speed.

- Use double seal approach.

Film Producing

Plating solutions, hard water, hot oil, etc., form a layer of film across seal faces and often stick and tend to roll up, causing the faces to separate.

- Use double seals, with the barrier fluid at least 15 psi (1 bar) greater than seal chamber pressure.
- Quench and drain.

Hot Products

Hot oil, liquid sulfur, heat transfer products coke, become film building, and also build up on the atmospheric side of seals, much like crystallization residue, only sticky.

- Use restriction bushing
- Use hi-temp metal bellows
- Flush with cool product
- Double seal with cool barrier fluid 15 psi (1 bar) greater than seal chamber pressure).
- In some cases, flush, quench and drain, flush with cool fluid, quench with steam.

Non-Lubricants

Liquefied petroleum gas, solvents, products with low specific gravity, boiler feed water should be cooled, in some cases, to avoid flashing and abrasion.

- Cooling can be achieved by using a pumping ring with double seals
- Use coolers (heat exchangers) for cool barrier
- Quench and drain, depending on the situation and availability, to isolate product from atmosphere and prevent freezing (liquefied petroleum gas) and quench to drain.

NOTE: Always use carbon as one of the face materials if compatibility is not a problem (Carbon vs. Silicon Carbide is the coolest running face combination).

Slurries

Raw product, lime slurry, dirty water, and sewage are the kinds of products that clog seals, abrade metal parts and damage faces.

- Use hard faces against product.
- Use a double seal with the barrier fluid at least 15 psi greater than seal chamber pressure.
- Use a quench and drain, with some single seals, to avoid clogging on atmospheric side by quenching debris to drain.
- Flush from an outside source and use a restriction device in the bottom of seal chamber to control the flush volume required for cooling while isolating the seal from the dirty product.
- Use a GPA seal, which is designed for slurry applications.

Solidification

Glue, polymers, asphalt, latex, paints, etc., will glue seal faces together resulting in seal damage at start up. These products also restrict the flexibility of mechanical seals.

- Double seal with appropriate barrier fluid can help and is historically the way most seal companies choose.
- Quench with steam or hot water can often control solidification, depending on the product.
- This is normally an area that calls for a P/S[®]-II seal, with proper environmental controls.
- Steam jackets are often

used. Vaporizing Products

Hot water, propane, liquefied petroleum gas and Freon cause flashing between the faces, which blows the faces apart, causing leakage and damage to the faces as they crash together (chips on face O.D. is most common sign).

- Use cool running faces (CBN vs. SC)
- Double seals are often used
- A cool flush may help prevent flashing
- Quench and drain to control temperature on the atmospheric side of the faces and prevent freezing in the case of some light gases.
- Control the pressure with a discharge return to seal chamber, this raises pressure above the flash point.

Viscous

Asphalt, cold oil, sugar and syrups are some products that are thick and viscous. Therefore, they create problems much the same as solidification.

- The P/S[®]-II Seal can be used to overcome most problems. Often environmental controls are required.

NOTE: Protect the integrity of the environmental controls as if it were the process itself, because the process reliability is almost always directly dependent on a specified environmental control. If they were not important, they would not be prescribed.

Design/Style

Advantages of O-Ring Secondary Seals

These are some of the advantages of O-rings used as secondary sealing devices.

- Easy to install.
- Impossible to install backwards.
- Seal in both directions (pressure or vacuum)
- They flex and roll.
- Takes longer to fret a shaft than other options.
- Readily available.
- Wide range of elastomeric compounds.
- Controlled loading by machined slots and hydraulic/pneumatic pressures.
- Compensate for misalignment better than other types (U-seal, wedge, etc.)
- Relatively low cost.

Installation

NOTE: Each mechanical seal must be installed at its proper operating length/working length.

A mechanical seal's operating length, also referred to as working length, is the proper axial length of the seal, when it is installed for service. If the seal's mechanical loading device (spring or springs) is not properly compressed, the sealing unit is not at its proper operating length. The proper operating length depends on the type of mechanical seal and type of springing device (multiple, single, wave spring, etc.). In addition, there are component and cartridge types, which dictate different methods of achieving the proper operating length. It is important to read the installation instructions, before installation proceeds.

Common Causes for Wrong Working Length Setting

1. No print available or mechanic did not use installation print.
2. Impeller adjustment is made after the seal is secured to the shaft.
3. Measurements for reference marks were made without gaskets in place and/or equipment was not bolted together tightly.
4. Failure to properly locate drive pin into keyway slot of the pump sleeve.
5. Did not make sure the gasket thickness was consistent (it affects the setting length measurements).
6. Scribe marks are too wide, which can cause inaccuracy.
7. Did not use stuffing box face for first line of reference.
8. For seals that are set on a sleeve or against the impeller, the working length is changed, in a negative way, if the seal chamber face is altered or an impeller adjustment is made.
9. If impeller adjustments are routinely made, without disassembling the pump, a cartridge seal should be used, which allows the seal to be reset after impeller adjustment.
10. Misinterpretation of print, between a recess and a protruding seat, when making reference/interface line (Figure 21).

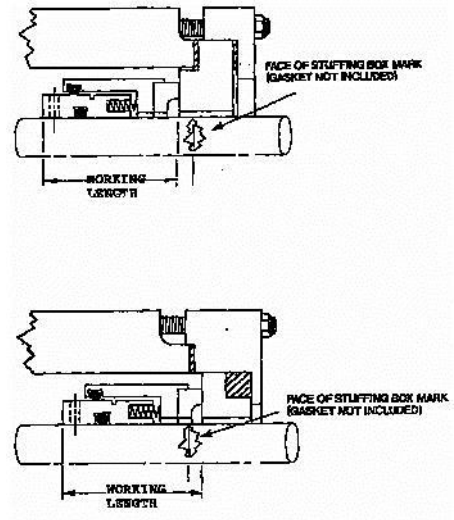

Figure 21

Environmental Controls

Double Seals by Application

A double seal by application (Figure 26) is comprised of two (2) mechanical seals applied to a single seal chamber for the purpose of sealing a product that is a VOC, dirty, non-lubricating, or very viscous. Also, they are used for products that solidify or otherwise change state.

The reason for a double seal is to stop the migration of the sealed media from crossing the primary seal faces. Products that damage the faces, or glue them together, can not be permitted to migrate across the faces. To work properly, the barrier fluid must be maintained at a pressure no less than 15 psi (1 bar) greater than the seal chamber pressure (One atmosphere 14.7 psi (1 bar) at sea level).

When the primary seal leaks, the barrier fluid will leak into the product; so the barrier fluid must be compatible with the product and non-hazardous to the environment. In addition, it must be clean and non-foaming.

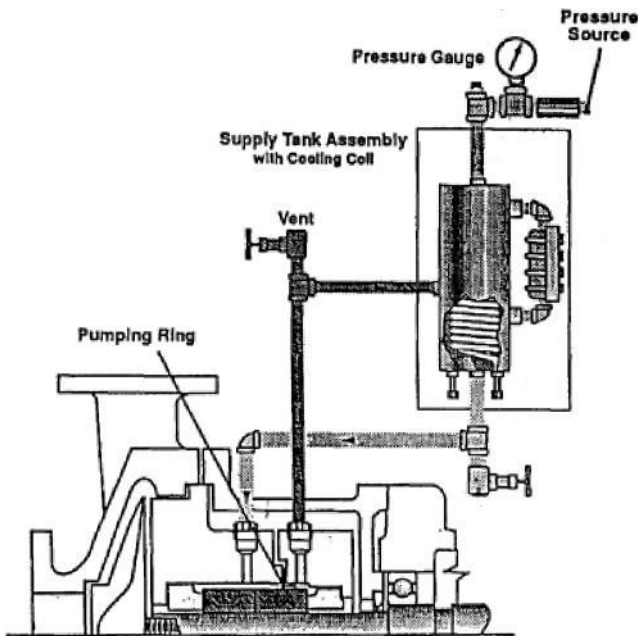

Figure 22 - Typical double seal with forced circulation style

Tandem Seals by Application

A double seal used as a tandem seal by application (Figure 27) is much the same as a standard double seal, except for the pressure of the barrier fluid. Tandem seals are used to seal dangerous VOC and VHAP products or any media producing emissions that must not escape to the atmosphere. Often this kind of arrangement will include a vapor recovery system.

The barrier fluid will be maintained at atmospheric pressure, low pressure or non-pressurized. The barrier fluid's low pressure will allow the leaked product to enter the

buffer system when the primary seal leaks. The buffer fluid must be compatible with the pumped media and atmosphere.

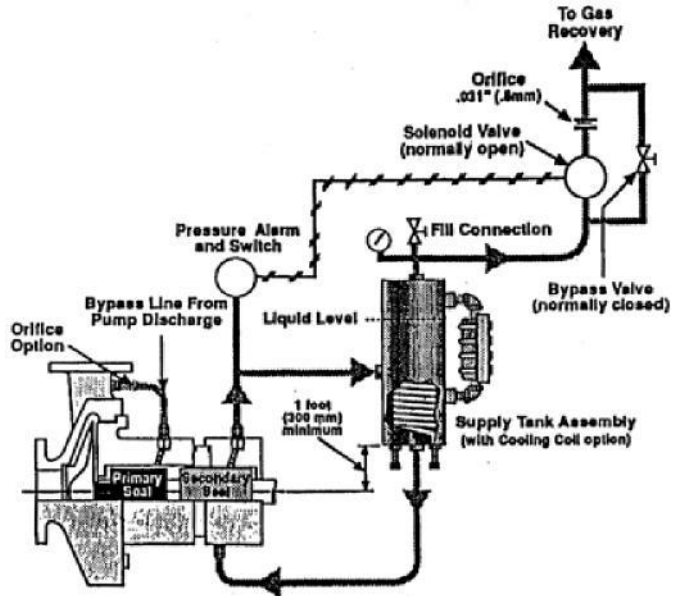

Figure 23 - Typical tandem seal and system

Tandem seals by design (Figure 23) are in line and facing the same direction. These seals are double seals designed for high pressure (greater than 150 psi (10 bar)). If they were not facing in the same direction, and acting as two independent inside seals (fluid does not come to the I.D of the seal), they would be limited to 150 psi (10 bar) —the pressure limit of an outside seal by design (Figure 10). When the first (inside mounted design) seal leaks, the product will migrate into the buffer area and be sealed by the outboard seal, which is designed and positioned in the same direction as the inboard seal. In the tandem design, both the inboard and outboard seals are designed to seal 300 psi (21 bar) or more because the pressure is on the outside of the seal (see Figure 14).

NOTE: Barrier fluid pressure is important. Barrier fluid is pressurized where buffer fluid is not pressurized. If the pressure of the barrier fluid is at atmospheric pressure, the pumpage can migrate from the seal chamber across the faces, lubricating them, and vaporizing into the buffer area, between the inboard and outboard seals. Conversely, if the barrier fluid is 15 psi (1 bar) greater than the seal chamber, the barrier fluid will migrate across the faces vaporizing into the seal chamber.

Never allow the product and barrier fluid to be at equal pressure with the pumped product. If both the product and the barrier fluid are at equal pressure, each will migrate to the center of the seal faces, the dynamic faces will generate heat and vaporization will occur between the faces (flashing). At the point of flash, the faces will

separate causing leakage, damaging the faces, and the seal will fail (Figure 24).

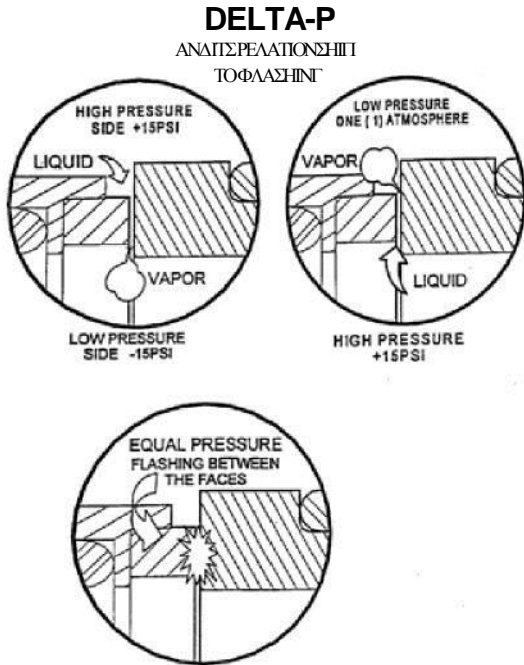

Flush

A flush (Figure 26) introduces a small amount of fluid into the seal chamber, in close proximity to the sealing faces, and usually used for cooling or other protection of the faces. Flush can come from an outside source or recirculated from the pump discharge, and often recirculated through filters and/or a heat exchanger. Any liquid used for flush is introduced into the product and can cause dilution or contamination in excessive amounts. Choose carefully.

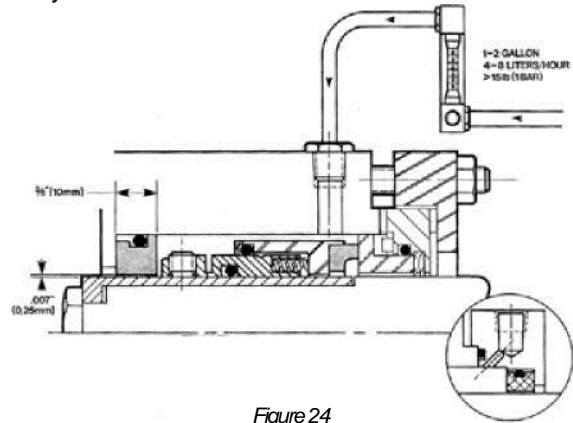

Figure 24

Figure 26 - Flush From An Outside Source and Metered

Barrier Fluid

Barrier fluid or buffer fluid (Figure 25) is a liquid or gas introduced between two (2) seals. Care must be taken when choosing barrier fluid for an application. A barrier/buffer fluid should be:

- Clean
- Lubricating
- Compatible
- Non-hazardous
- Non-foaming

Water, propylene glycol, propyl alcohol, automatic transmission fluid, kerosene, No. 2 diesel fuel, mineral oil and synthetic oils are a few of the most common barrier fluids.

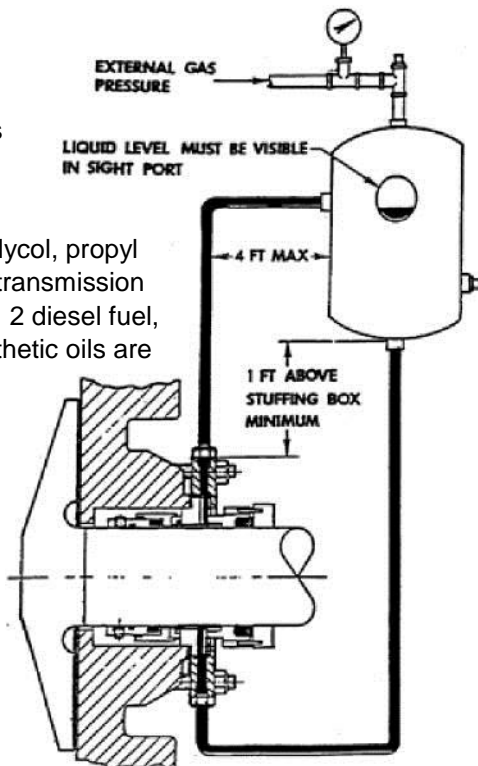

Figure 25

Vent and Drain

The vent/quench and drain (Figure 27) introduces a neutral fluid, gas or steam through the gland plate on the atmospheric side of a seal. The purpose of this fluid or gas is to dilute product that may have precipitated across the seal faces to atmosphere and/or quench debris from the underside of the seal faces while cooling the seal or heating the seal.

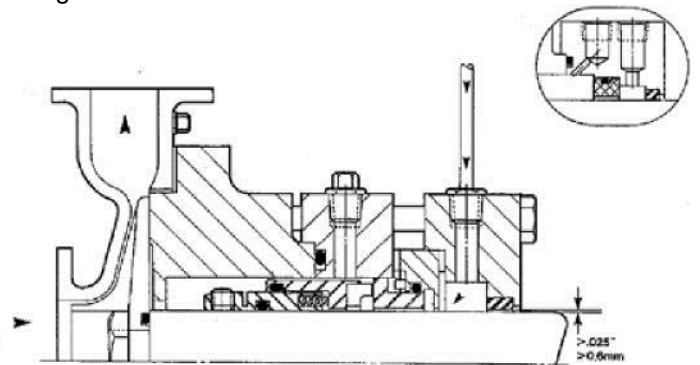

Figure 27 - Quench / Vent & Drain

Dangerous products can be quenched, diluted and drained to a collection point or flair stack (API process). If the product creates residue under the seal faces, it can be washed away to drain and minimize build-up. If a product is heat sensitive, quenching can control temperature and alleviate the problem, be it heating or cooling.

Jacketed Stuffing Box with Restriction Bushing

This method (Figure 28) is used to control temperature in the seal chamber. Jacketed seal chambers may be used for cooling or heating. In this arrangement, a heat transfer fluid is normally introduced through the jacket void and returns to its source or, less often, to a drain. This heat transfer fluid is not introduced into the system media. Always use a restriction bushing in the bottom of the seal chamber. Because of the restriction bushing's close clearance to the pump sleeve/shaft (0.006" to 0.008" (0.15mm to 0.20mm)), it isolates the seal chamber from the system temperature. By doing this, temperature control is more manageable, since the flow is limited and the temperature of the heat transfer fluid can be cooled or heated, depending on the application requirements. When using this arrangement, it is imperative to vent or bleed all air from the seal chamber before start up (Figure 29).

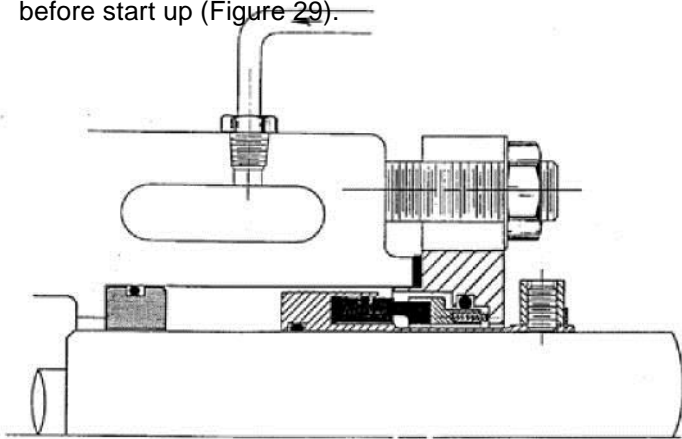

Figure 28 - Jacketed Seal Chamber with Restriction Bushing

To Vent Air from the Seal Chamber:

1. Install the seal, then the pump, to the piping.
2. Install a bleed valve at the top of the seal chamber, with a line directed to a collection vessel.
3. Install flush, quench and drain as required.
4. With the discharge closed, open the suction valve slowly.
5. Using the bleed valve, carefully bleed the air from the seal chamber until a constant flow of product is discharged into the collection vessel.
6. Close the bleed valve.
7. Remove the bleed valve handle and tag the valve.
8. Proceed with proper pump activation procedures.

NOTE: Actual testing has proven it possible, with a cooling jacket, to cool an ANSI Group II Pump pumping hot oil, from 650°F (343°C) to 250°F (121°C), by using this method. Reducing temperature improves seal life, in the following ways:

1. Reduces flashing between faces.
2. Prevents coking.
3. Protects o-rings from overheating.
4. Reduces harmful heat related face damage.

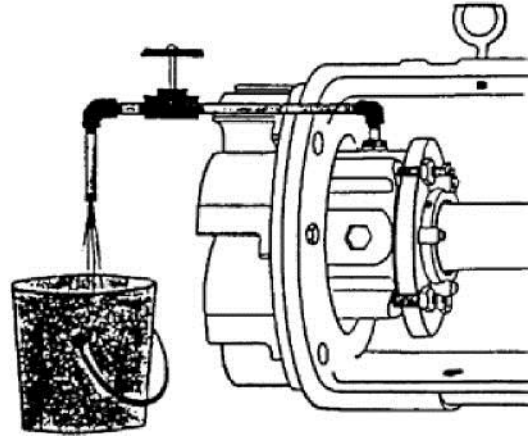

Figure 29 - Vent air from seal chamber

Heat Exchangers

Heat exchangers are used to add or remove heat from the seal area, depending on the application requirements. Best results are achieved when used in conjunction with a restriction bushing pressed into the base of the seal chamber, which isolates the seal from the process fluid by increasing pressure in the seal chamber and increasing velocity of the flush through the close clearance bushing (Figure 30). Normal bushing clearance is 0.006" to 0.008" (0.15mm to 0.20mm) on each side of the pump shaft/sleeve.

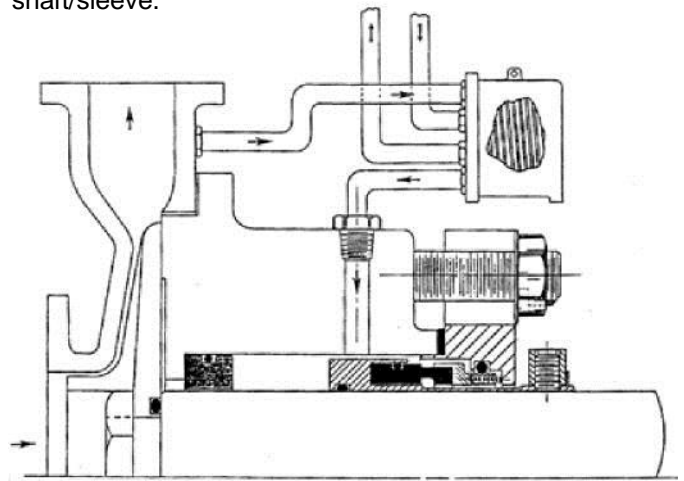

Figure 30 - Discharge Return Flush Through Heat Exchanger

Recirculation, Suction Return

Most pumps have lower gage pressure at suction and higher pressure at discharge. The seal chamber pressure is normally higher than or equal to suction pressure, but lower than discharge pressure. Flow between the seal chamber and suction can be created by attaching a tube from the seal chamber to the suction line. When both suction and discharge valves are open, the connecting tube will ensure that fluid is in the seal chamber, even if the horizontal pump is not running. This arrangement also acts to vent air from the seal chamber of vertical pumps (Figure 31).

While the pump is running, the media will circulate from higher pressure to lower pressure or from the seal chamber to the suction line. This creates circulation through the seal chamber, transfers heat generated by the faces, and lowers the pressure in the seal chamber without diluting the product.

When using a suction return, and debris is present in the fluid, it is often a good idea to place the flush port on the bottom, facing down. As the pump runs, the recirculation between the seal chamber and suction will act as a vacuum line. By evacuating debris to suction, it will prevent build-up of particulates, which could settle to the bottom of the seal chamber when the pump is shut off, and bind against the seal at start-up, causing the seal faces to open.

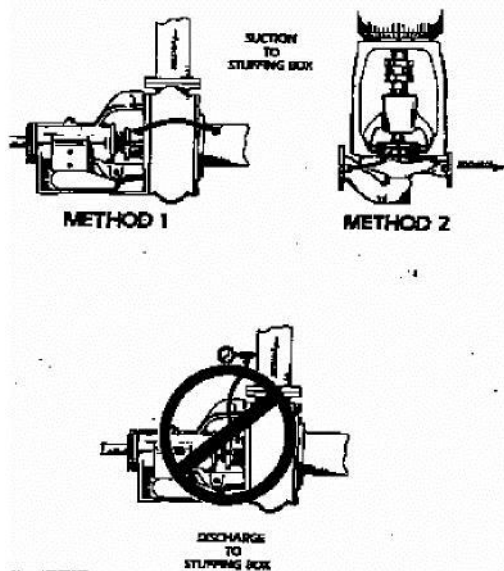

Figure 31 - Recirculation Suction Return

NOTE: The suction return method should not be used if the seal chamber pressure and temperature are within one atmosphere of the flash point range of the product being pumped or if the seal chamber and the suction are the same pressure.

Recirculation, Discharge Return

A discharge return (Figure 36) is simply a circulation tube from the discharge line to the seal chamber, which creates flow. This method is used to circulate the heated media, generated by the seal faces, out of the seal chamber. Often it is used to keep product from flashing by raising the seal chamber pressure above the flash point.

The discharge return type recirculation can also cause problems for mechanical seals by raising the seal chamber pressure, which in turn can increase heat, blast debris at the seal, causing erosive wear, and can erode the circulation tube.

NOTE: Ask yourself, "What will happen in the seal chamber if I use discharge return or suction return?" Then choose, using sound logic.

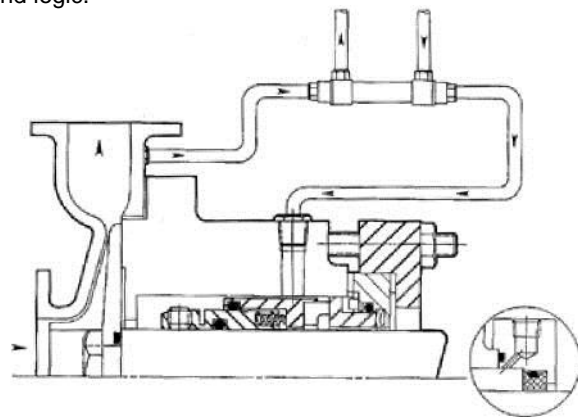

Figure 32 - Recirculation Discharge Return

Other Types of Environmental Controls

These include:

- Flush using heat exchanger
- Flush through cyclone separator or filter
- Double seal using convection system
- Double seal with outside forced circulation
- Double seal with internal pumping ring

If, for some reason, the environmental control on a given system stops working, the life of the seal will be shortened. In some cases failure will be quick, such as double seals running at high speed. In other cases, a problem will not occur until the system is shut down and started again, such as asphalt, which will solidify if not properly heated.

Typical causes of failure with environmental controls include:

- Improper installation
- Improper maintenance
- Poor operational practices

Mechanical Seal Styles

P/S®-II Flexible GYLON® Element Cartridge Seal

Effectively seals dense and viscous fluids

The P/S-II seal is a cartridge mounted multi-lip seal, which is designed to seal those thick, viscous, temperature sensitive products that create problems for face seals. The P/S-II seal is extremely successful sealing positive displacement and centrifugal pumps, within the published operating limits. The seal is not recommended in applications where the sealed product contains solids. Simple repair kits available.

Benefits

- ◆ GYLON® sealing elements
 - Are non-clogging/non-sticking in viscous fluids
 - Offer excellent chemical resistance and dry running capability
- ◆ Unique multi-lip cartridge design
 - Is unaffected by axial end play, intermittent operation or torque
 - Permits pump reversal
- ◆ Machined gland is very versatile; designed to fit the equipment
- ◆ Hard coated sleeve prevents damage to equipment
- ◆ Rebuild kit available for easy in-field repair
- ◆ One moving part, no springs to clog

Ideal for

- ◆ Positive displacement pumps:
 - Viking
 - Moyno
 - Blackmer
 - Roper
 - Tuthill
 - Many others
- ◆ Centrifugal pumps:
 - Durco
 - Many others
 - Goulds
- ◆ Mixers
- ◆ Conveyors
- ◆ Rotary valves



Materials

- ◆ Metal parts: 316SS (other materials available)
- ◆ Set screws: Hastelloy C*
- ◆ O-rings: Fluoroelastomer standard (other materials optional)
- ◆ Sealing elements: GYLON®
- ◆ Sleeve coating: Chrome oxide standard (other coatings optional)

*Hastelloy C is a registered trademark of Haynes International. Other materials available. Consult Garlock Klosure.

Typical Applications

- | | |
|-------------|------------------|
| ◆ Adhesive | ◆ Oil |
| ◆ AFFF | ◆ Paints |
| ◆ Asphalt | ◆ Paper coatings |
| ◆ Chocolate | ◆ Polymer resins |
| ◆ Emulsions | ◆ Sealants |
| ◆ Fats | ◆ Soaps |
| ◆ Fructose | ◆ Starch |
| ◆ Fuels | ◆ Syrups |
| ◆ Glue | ◆ Tallow |
| ◆ Ink | ◆ Tar |
| ◆ Latex | ◆ Varnish |
| ◆ Molasses | ◆ Wax |

P/S[®]-II (continued)

Specifications

Pressure	To 150 psi (10 bar)
Vacuum:	28" (711mm) Hg with proper design
Temperature:	To 300°F (-149°C); Over 300°F, consult Garlock Klozure Mechanical Seals
Surface Speed:	To 700 fpm (3.5 m/s) dry; to 2,500 fpm (12.7 m/s) with lubrication
Runout:	Up to 0.005" (0.13 mm) TIR
Axial motion:	± 0.125" (3.2 mm)

Standard 3-lip Design with Quench Ports

Round, elliptical and other special gland
configurations available

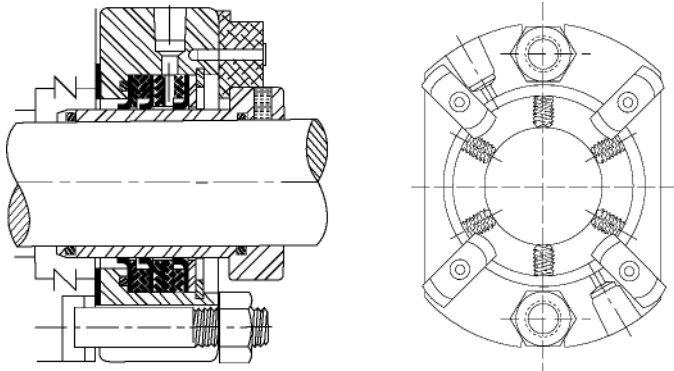

Style 85

(P/S®-I MILL-RIGHT® Machined)

The Style 85 seal is similar to the P/S-I seal in that it is a single, or multiple-lip seal in a single casing. Because each seal is machined, it can be manufactured in various sizes and configurations, without special tooling requirements. Because the Style 85 is o-ring mounted, it can be installed and removed without damage. Repair of Style 85 must be performed at a certified Garlock repair center.

Benefits

- Can be machined to fit special sizes and configurations, without special tooling
- Can be extracted without damage to the seal housing
- Can be made into single or multiple sealing element units within a single body
- Environmental control between multiple sealing elements
- Can be rebuilt (at Garlock)

Construction

- Stainless steel (machined inner and outer housing)
- GYLON® used as gasket sealing element
- O-ring mounted (o-ring compound is determined by the application)
- O-ring to bore installation
- Anti-rotation pins, snap-ring or clamping plate to prevent seal rotation in bore



Specifications

Pressure	150 psi (10 bar) with cover plate, 75 psi (5 bar) without
Vacuum:	Full vacuum with lip facing away from source
Temperature:	-40°F (-40°C) to 400°F (205°C); Over 400°F consult Garlock Klosure Mechanical Seals
Surface Speed:	700 fpm (3.5 m/s) dry; to 1,800 fpm (9.1 m/s) with lubrication
Max. Runout:	0.005" (0.13 mm)
Shaft finish:	4 to 8µ in. Ra (0.10 to 0.20 µm Ra)
Shaft hardness:	50 to 70 Rockwell C recommended
Bore finish:	100µ in. Ra (2.54µm Ra)

GYLON®, P/S® and MILL-RIGHT® are registered trademarks of Garlock Inc.

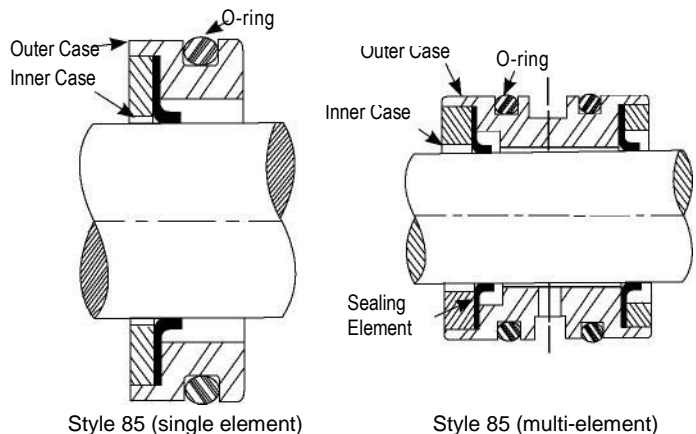

Style 3-D Mixer/Agitator Seal

The 3-D Mixer/Agitator seal is design to operate in equipment where shaft movement, in all directions, is excessive and where the shaft must be sealed. The 3-D seal will accommodate up to 1.00" (25.4MM) shaft movement. The 3-D seal uses P/S technology as a sealing set, a bearing to maintain a state of parallelism between the seal body and the shaft. An expansion joint acts as a flexible member and absorbs the movement. NOTE: Larger expansion joints will accommodate more movement than smaller ones. Repair kits are available for easy repair.



Specifications

Pressure	28" Hg (711 mm Hg) to 150 psi (10 bar)
Vacuum:	Full vacuum with lip facing away from source
Temperature:	300 F (135 C)
Surface Speed:	2,500 fpm (12.7 m/s)
Sleeve finish:	4 to 6μ in.
Sleeve hardness:	50 to 70 Rockwell C
Sleeve coating:	Specified based on application
Sleeve and seal housing material:	316SS, 20SS, Hastelloy, titanium
Flexible housing material:	PTFE, 316SS, Hastelloy C 276
Movement Capability:	1" Total Indicated Runout (TIR) 1" Total Axial Movement (TAM) (specific movements calculated per application)

*Above 150 psi, consult KLOZURE®

Types of Shaft Movement

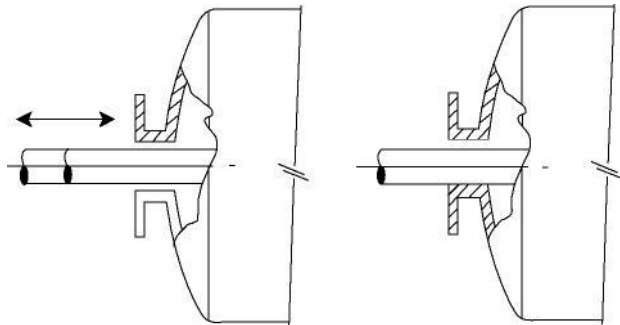

Axial Movement

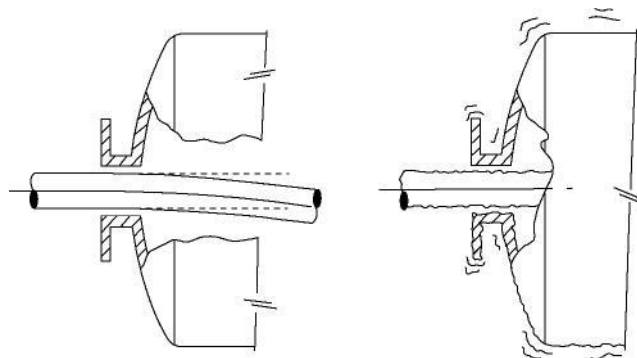

Shaft Deflection

Vibration

Detailed View

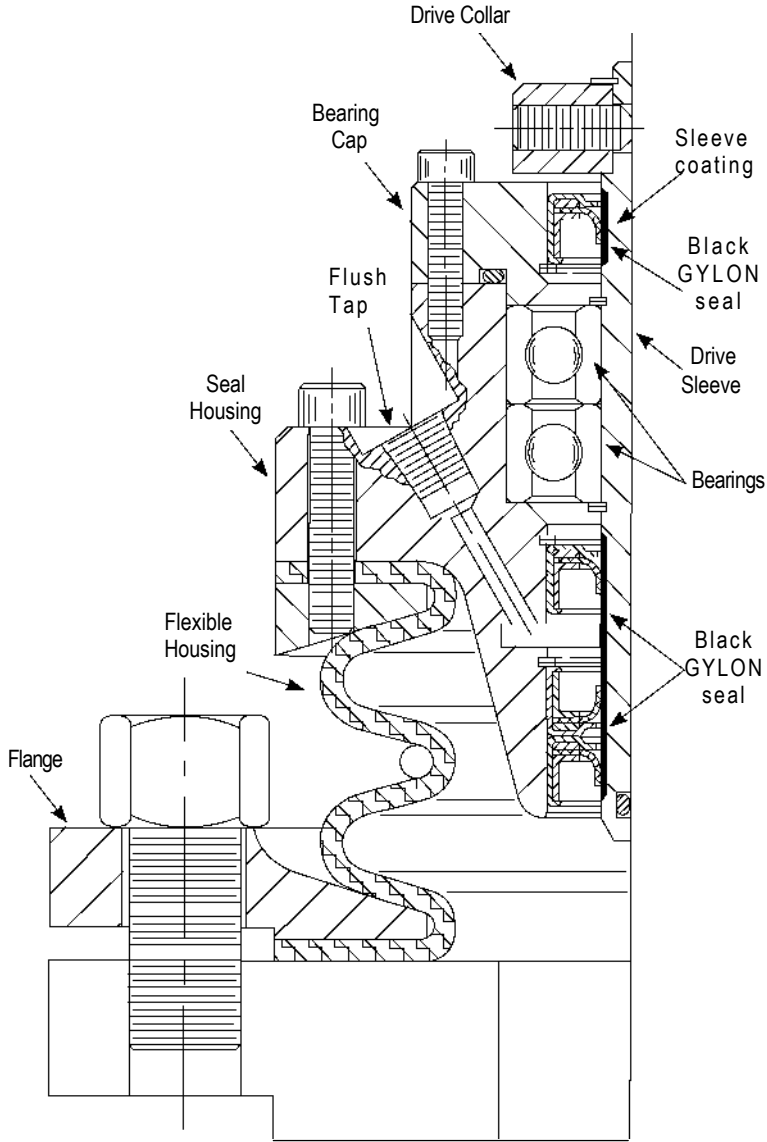

Typical Seal Arrangements

Tandem	Double	Vacuum & Double	Staged Lips	Date End Face Seal

Cartridge Face Seals

GMP-I Single Cartridge Seal

Cost-effective and versatile balanced seal

A single cartridge mounted face seal, which has a stationary balanced design, for service in higher pressures and higher speeds than typical unbalanced alternatives. The GMP-I is for use in clean general service and moderate abrasive service. The GMP-I seal is available in a wide range of materials to accommodate application requirements. Its balanced design allows it to perform in pressure and vacuum service. Repair kits are available for easy repair.

Benefits

- Preassembled cartridge is easy to install
- Balanced internal design runs cooler and provides longer seal life
- Fits standard ANSI pumps — no modification required
- Rebuild kit available for easy in-field repair and reduced downtime
- Attached setting clips prevent lost parts or damage to equipment
- Minimal distance to first obstruction; dimensionally compatible with a wide range of bearing protectors
- Stationary springs allow better face/seat alignment

Materials

- Metallurgy: 316SS and Alloy 20
- Rotary face: Silicon carbide (SA)
- Stationary face: Chemical grade carbon; tungsten carbide
- Springs: Hastelloy C*
- O-rings: Fluoroelastomer standard, Aflas** or Kalrez*** offered as alternative

*Hastelloy C is a registered trademark of Haynes International.

**Aflas is a trademark of Asahi Glass Company

***Kalrez is a registered trademark of DuPont.

Other materials available. Consult Garlock.



Specifications

Pressure	To 300 psi (20 bar)
Vacuum:	28" (711 mm Hg)
Temperature:	To 400 F (204 C)
Surface Speed:	5,000 fpm (25.4 m/s)
Runout:	Consult Garlock Klozure
Axial Motion:	Consult Garlock Klozure

Other Versatile Seals

- GMP-II Double Balanced Cartridge Seal
 - Ideal for a wide range of rotary equipment
 - Fits all standard ANSI pumps
 - Compact design, easy to install and repair
 - Balanced configuration runs cooler
- P/S®-II Flexible Element Cartridge Seal
 - Effectively seals dense and viscous fluids
 - GYLON® sealing elements are chemically resistant and allow dry running
 - Easy in-field repair reduces costly downtime

Standard Configuration

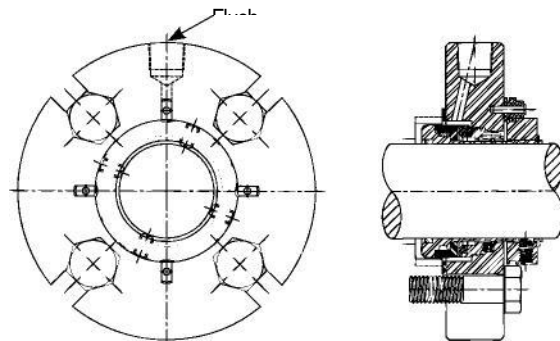

GMP-II Double Cartridge Seal

High-quality, cost effective balanced seal

A double cartridge mounted face seal which is both stationary and balanced which can be used in higher pressures and at higher speeds than unbalanced alternatives. It can be used with a pressurized barrier fluid (double seal applications) or unpressurized buffer fluid (tandem applications).. The GMP-II seal is available in a wide range of materials to suit the application requirements. Repair kits are available for easy repair.

Benefits

- Easy-to-install double cartridge design
- Balanced configuration runs cooler and lasts longer
- Cost-effective rebuild kits for easy in-field repair and reduced downtime
- Fits standard ANSI pumps — no modification required
- Stationary compression units offer improved face alignment and extended seal life
- Minimal distance to first obstruction; fits a wide range of pumps

Materials

- Metallurgy: 316SS and Alloy 20
- Rotary face: Silicon carbide (SA)
- Stationary faces: Inboard: chemical grade carbon; tungsten carbide; Outboard: chemical grade carbon
- Springs: Hastelloy C*
- O-rings: Fluoroelastomer standard, Aflas** or Kalrez*** offered as alternative

*Hastelloy C is a registered trademark of Haynes International.

**Aflas is a trademark of Asahi Glass Company

***Kalrez is a registered trademark of DuPont.

Other materials available. Consult Garlock.

Specifications

Pressure To 300 psi (20 bar)



Vacuum: 28" (711 mm Hg)
Temperature: To 400°F (204°C)
Surface Speed: 5,000 fpm (25.4 m/s)
Runout: Consult Garlock Klozure
Axial Motion: Consult Garlock Klozure

Other Versatile Seals

- GMP-I Single Balanced Cartridge Seal
 - Ideal for a wide range of rotary equipment
 - Fits all standard ANSI pumps
 - Compact design, easy to install and repair
 - Balanced configuration runs cooler
- P/S® -II Flexible Element Cartridge Seal
 - Effectively seals dense and viscous fluids
 - GYLON® sealing elements are chemically resistant and allow dry running
 - Easy in-field repair reduces costly downtime

GYLON® and P/S® are registered trademarks of Garlock Inc.

Standard Configuration

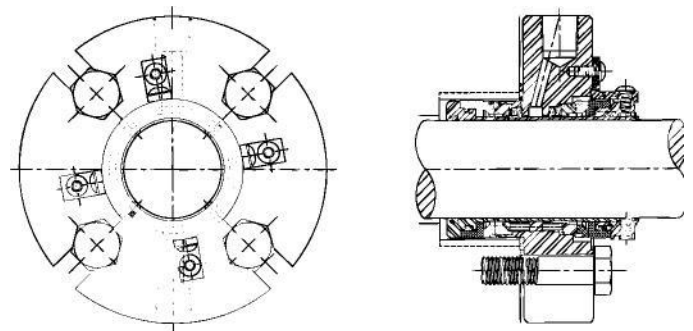

Style 35/35FS

Heavy duty single cartridge seal

The type 35-seal is a heavy duty single spring cartridge seal designed for thick or abrasive slurry service. The large single spring acts as an auger and resists clogging in applications that are difficult for multiple spring seals. Repair kits are available for simple repair.

Style 35FS is a unique seal utilizing a P/S-I lip seal as an excluder. The P/S-I fits into the bore of the seal chamber and rides on a replacement stub sleeve. The result is a seal combination that operates in slurries with a minimum of flush water. Repair kits are available for easy repair.

Benefits

- Easy installation
- No shaft/sleeve fretting
- Superior clogging resistance
- No pump/sleeve modification
- Simple in-field repair

Features

- Preset cartridge seal
- Static shaft O-ring
- Heavy duty single spring
- Designed to fit ANSI pumps
- Cost-effective repair kit

Materials

- Metallurgy: 316SS
- Set screws: Hastelloy C
- Rotary face: chemical grade carbon or tungsten carbide
- Stationary face: Silicon carbide (SA)
- Spring: 316SS
- O-rings: Fluoroelastomer standard

*Hastelloy C is a registered trademark of Haynes International.



Specifications

Pressure	150 psi (10 bar)
Temperature:	400 °F (204 °C)
Speed:	1,500 fpm (7.6 m/s)

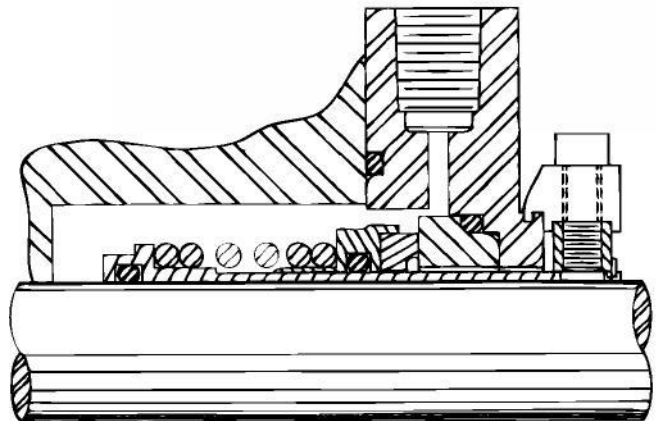

Style 35

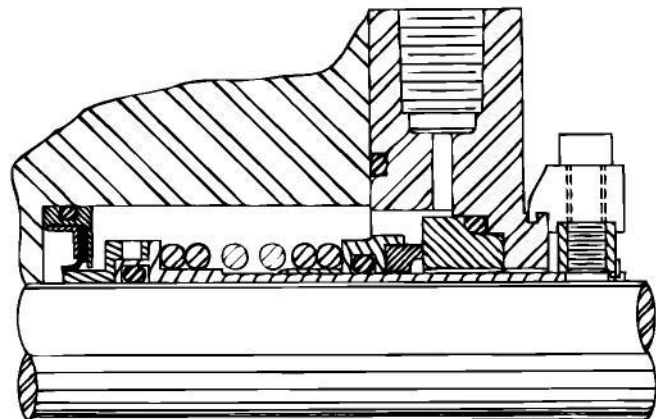

Style 35FS

Style 19/20

Compact seal for vertical pumps, mixers and agitators

The type-19 seal is a double concentric face seal designed for mixers and agitators or equipment where radial shaft movement is beyond accepted limits for typical face seals. The Type-19 will accommodate up to 1/8" (03.18MM) of radial shaft movement. Its concentric face design allows it to be mounted to equipment and requires no counter-bore for mounting. Because of its stationary design, it will accommodate high speed. This seal requires a barrier or buffer fluid to be used between the inner and outer faces. The Type-19 is available in materials to suit most application requirements. Repair must be done at Garlock's certified repair center.

The type-20 seal is a single balanced cartridge seal that is (similar to the Type-19), capable of accommodating 1/8" (03.18MM) of radial shaft movement. The Type-20 is a stationary design and can operate at higher speed and pressures than many other alternatives. Because it is a single seal, the faces must be flooded while in service. Repair must be performed at Garlock's certified repair center.

Benefits

- Can withstand .125" TIR
- No stuffing box required
- Fits a wide variety of equipment
- Minimizes vibration and harmonic distortion
- Easy installation
- Services a wide variety of applications
- Field repairable

Features

- Wide rotary face design
- External seal
- Compact axial length
- Stationary design
- Cartridge seal
- Single/double design
- Repair kit available



Materials

- Metallurgy: 316SS
- Set screws: Hastelloy C
- Rotary face: Silicon carbide (SA) or tungsten carbide
- Stationary face: chemical grade carbon or tungsten carbide
- Springs: Hastelloy C
- O-rings: Fluoroelastomer standard

*Hastelloy C is a registered trademark of Haynes International.

Specifications

Pressure	Style 19: 300 psi (21 bar) - double Style 20: 400 psi (28 bar) - single
Temperature:	-40°F (40°C) to 350°F (175°C)
Speed:	4,000 fpm (20 m/s)

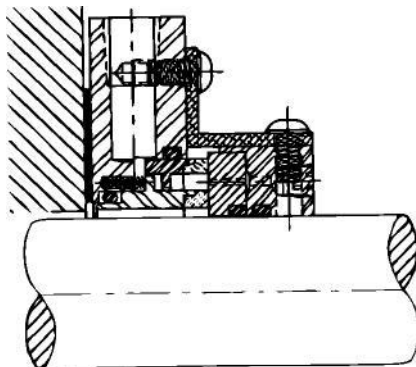

Style 19 — Double seal

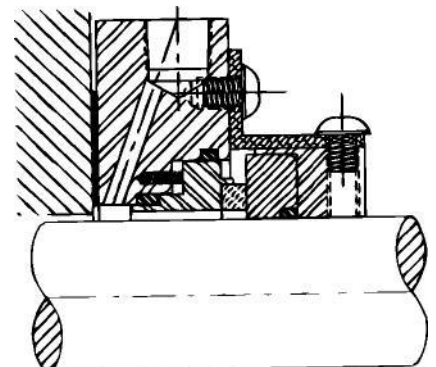

Style 20 — Single seal

Syntron® RP Mechanical Shaft Seals

Compact cartridge double seal ideal for sealing gases and fluids

A double seal utilized as the critical seal in a broad range of equipment in the industrial market including industrial fans and autoclaves. The Syntron RP seal has also proven to be highly effective on propeller shafts and thrusters in the marine industry.

Features and Benefits

- Cartridge design for ease of installation
- Fully repairable on site with repair kits available reducing the cost of ownership
- Available in a broad range of materials for a variety of applications
- Excluder available for mildly abrasive services

Materials

Depending on the process and the fluid to be pumped, the Garlock Klozure engineering staff will assist you in selecting the best materials for the following key components: Metallurgy: 316SS

- Housing: Brass (Standard) - 316SS, C-20, Hastelloy C and others optional
- Seal Faces: Carbon/Bronze (Standard)
- Elastomers: Hycar (Standard) - Neoprene, Viton, and others optional

*Hastelloy C is a registered trademark of Haynes International

Specifications

Pressure	Up to 150 psi
Temperature:	10 F (-12 C) to 300 F (149 C)
Speed:	Up to 3600 rpm
Shaft Size:	1.000" to 6.000"



Abrasive excluders can be installed on either end of the seal..

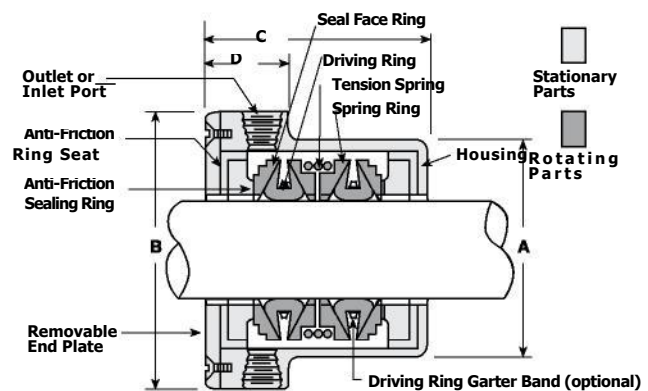

Syntron® RP Mechanical Shaft Seals (continued)

RP Mechanical Shaft Seal Installation

Syntron® RP Mechanical Shaft Seals are simple to install by performing the following instructions.

- (1) Make certain the RP shaft seal being installed is the correct size for the shaft being fitted.
- (2) Inspect shaft surface for defects, correct if necessary and polish shaft.
- (3) Coat shaft lightly with clean oil or grease.
- (4) Fit seal on the shaft and press into place with a slight wobbling motion. **Important: DO NOT FORCE!**
- (5) Position seal against gasket and secure to casing.

Caution: Syntron® RP Mechanical and Roll Neck Shaft Seals must be installed, operated and maintained in accordance with accompanying Garlock Klozure® Service Instructions. Failure to follow these instructions can result in serious personal injury, property damage or both. Garlock Klozure® Service Instructions accompany the shipment of equipment.

Fig. 1. Cooling by means of vented driving ring, using liquid being sealed. Flush connection ports plugged with pipe plugs.

Vent openings in the face of the driving ring permit the liquid being handled to enter the housing. In order that the vented ring can be placed in its correct location, seal mounting information must be furnished. This method can be used on slow speed (less than 2,000 rpm.) applications. Note: if liquid level drops below top of seal housing, all entrapped air must be purged.

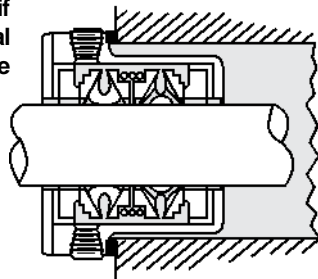

Fig. 2. Forced cooling by connections to inlet and outlet ports, using liquid being sealed.

The "RP" Seal Flush Connection feature consists of inlet and outlet ports in the housing flange, tapped for standard 1/8" pipe. Thus, either the liquid being sealed or an outside liquid, depending upon conditions enters the seal housing and provides forced cooling. Abrasive-laden or reactive liquids cannot be used as the cooling element.

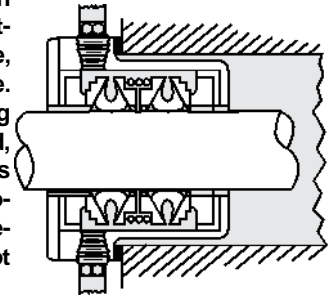
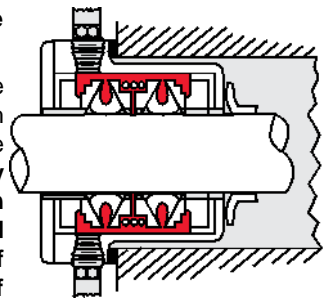
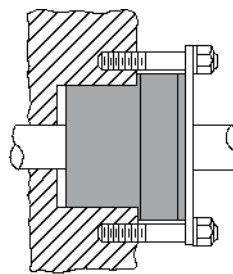

Fig. 3. Forced cooling by connections to inlet and outlet ports, using outside liquid.

The addition of the Abrasive Excluder to the "RP" Seal with Flush Connection permits the handling of abrasive liquids by making a positive seal between the shaft and seal. It is installed on the rotating shaft, forward of and in contact with either face of the seal. Abrasive-laden or active liquids cannot be used as the cooling element.



Typical Mountings of RP Mechanical Shaft Seals



When the gland space is large enough, the seal housing can be applied internally.

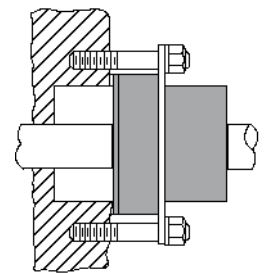

External application is made when the gland space is too small to take the seal housing.

GPA® Seals

Versatile design for a wide range of services

The GPA is an ideal seal utilized in a broad range of abrasive applications found in the Mining, Processing and Pulp & Paper industries. With its simple, sturdy, and proven design the GPA can be adapted to almost any industrial pump, mixer or agitator. The GPA is available in a wide range of materials and configurations to suit the specific application requirements.

Features and Benefits

- Does not require a flush thus minimizing the overall operating cost
- Designed to eliminate the risk of clogging which leads to seal failure
- Flexible design which allows the seal to be adapted to a variety of equipment
- Available in a cartridge design for ease of installation
- The GPA can be refurbished when needed



Materials

Depending on the process and the fluid to be pumped, the Garlock Klozure engineering staff will assist you in selecting the best materials for the following key components:

- | | |
|------------|--|
| Seal Faces | <ul style="list-style-type: none">• U5: Tungsten carbide with Cobalt• U6: Tungsten carbide with Nickel• U8: Silicon Carbide• C4: Siliconized Graphite |
| O-RINGS | <ul style="list-style-type: none">• B: Buna• E: Ethylene polypropylene• V: Viton• N: Neoprene |
| MEMBRANE | <ul style="list-style-type: none">• N: Neoprene• M5: PTFE coated• P1: Therban® (HNBR)• E: Ethylene polypropylene |
| SLEEVES | <ul style="list-style-type: none">• D: Carbon Steel• E: Chrome Steel• G: 316 L Stainless steel• T: Cr-Ni-Mo-Cu steel for phosphoric service |

Specifications

Pressure	To 300 psi (20 bar)
Temperature:	32 F (0 C) to 310 F (160 C)
Shaft Size:	0.788" (20 mm) to 7.085" (180 mm)
Speed:	5,000 fpm (25.5 m/s)

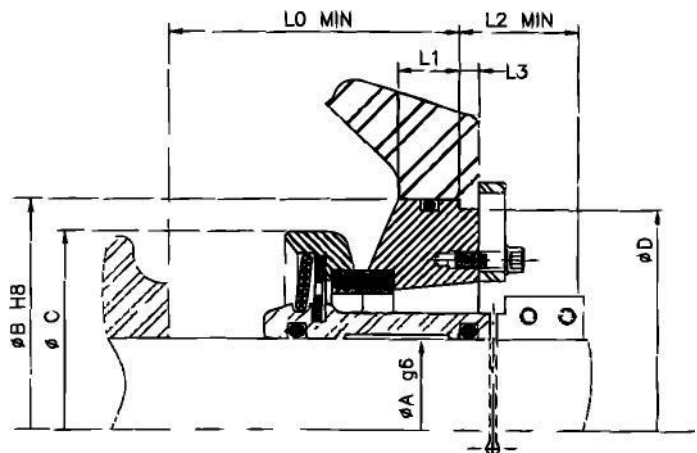

GPA® Seals (continued)

Design Options

The GPA® was the first mechanical seal specifically designed to handle highly abrasive slurries. GPA® seals are very forgiving because of their simple design. There are currently two options available:

- Threaded type, where the sleeve is threaded on one end, allowing the compression on the spring diaphragm to be adjusted precisely by moving it along the mating thread on the shaft or shaft sleeve. The threaded type allows for some fine tuning in the field.
- Cartridge type, which is preset at the factory and can be installed without further adjustment. It does not require special machining of the shaft or shaft sleeve for installation. The ease of installation of the cartridge type seal makes it ideal for the first time user. As your maintenance personnel become familiar with the operation of the GPA® seal, the threaded type should be considered.



Simplicity and Precision

The GPA® seal is basically comprised of two components: The Fixed Ring (a) inserted in a housing (c) integral with the pump body. The Rotating Seal Sleeve Assembly (RSSA) consisting of a rotating ring (b) inserted in a housing (d). Special drive rings (g) force the rotating housing to rotate integral to the seal sleeve (e). The spring diaphragm or membrane (f) connecting the rotating ring to the sleeve has three key functions:

- Acts as a static seal between the seal sleeve and the rotating housing
- Ensures consistent load between the fixed and rotating rings
- Aligns the housing to ensure that the rotation is perfectly parallel to the shaft and perpendicular to the shaft axis

As shown on the diagram, there is adequate clearance between the outside of the seal sleeve and the inside of the rotating housing to prevent any risks of clogging of the membrane and damage by loose crystals. A water flush port can be added on all seal types if desired.

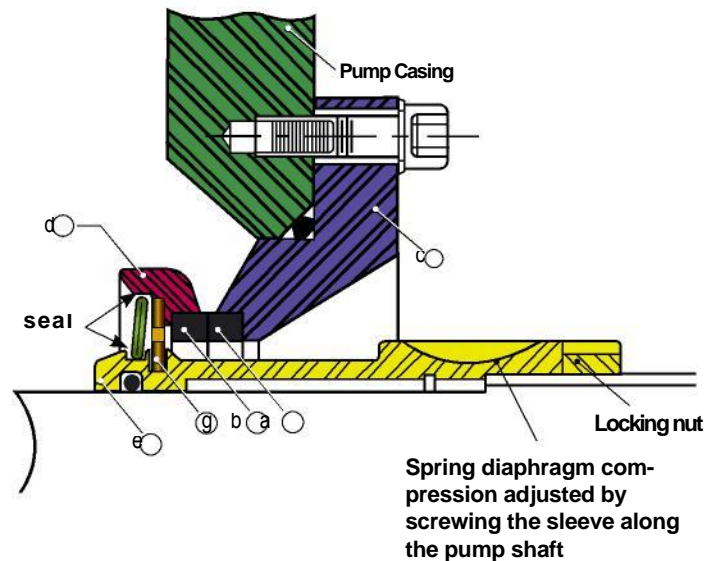

Component Seals

PK Mechanical Seal

High temperature metal bellows rotary

The PK seal provides economic and efficient sealing. The PK features a proven single spring, rubber bellows design protected by a stainless steel shell, which also allows the seal to turn in either direction. The PK seal is not a repairable seal.

Benefits

- Reliable, economical performance
- Unitized construction means simple installation, no loose parts to inventory
- Rubber bellows won't wear shaft or sleeve
- Fits in shallow stuffing boxes
- Won't clog in dirty environments
- Flexible rotary face floats to compensate for misalignment



Applications

- Centrifugal pumps
- Gear boxes
- Speed reducers
- Other rotating equipment

Specifications

Pressure	To 150 psi (10 bar)
Vacuum	To 28" Hg (711 mm Hg)
Temperature:	To 400° F (204° C)
Speed:	To 2,500 fpm (12.7 m/s)
Runout:	Consult Garlock Klozure
Axial Motion:	Consult Garlock Klozure

Materials

- Metallurgy: 316SS
- Springs: Stainless steel
- Bellows: Fluoroelastomer or nitrile
- Faces: chemical grade carbon and ceramic; silicon carbide and tungsten carbide optional. (see price list for other options)

Dimensions

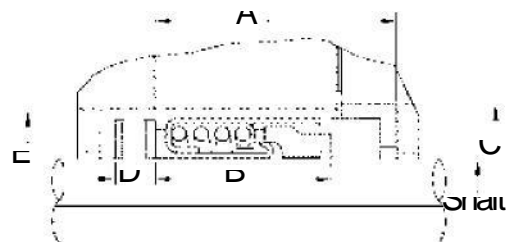

Style 80

Single inside rotary

The Type-80 is a balanced multi-spring single face rotary component seal, designed for a wide range of applications, including water, oils, chemicals and light slurry. It can be manufactured from a wide range of materials for face and seal body. The type-80 will seal pressure to 400 psi and vacuum. Repair kits are available for easy repair.

Benefits

- High psi capability
- Prevents clogging
- No shaft/sleeve wear
- No pump modification

Features

- Balanced design
- Isolated springs
- Static shaft O-ring
- Fits all ANSI pumps

Materials

- Metallurgy: 316SS
- Rotary face: chemical grade carbon, tungsten carbide
- Set screws: Hastelloy C*
- Springs: Hastelloy C*
- O-rings: Fluoroelastomer standard

*Hastelloy C is a registered trademark of Haynes International.



Specifications

Pressure	28" Hg (700mm Hg) vacuum to 400 psi (28 bar) depending on speed and pressure
Temperature:	-20° F (-30° C) to 400° F (204° C) with fluoroelastomer O-ring standard; -65° F (-55° C) to 300° F (150° C) with EPR O-ring; 0° F (-20° C) to 500° F (260° C) with Kalrez® O-ring (optional)
Surface Speed:	5,000 fpm (25.4 m/s)

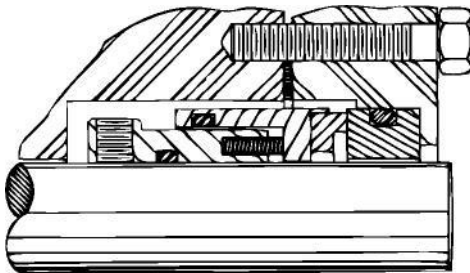

Standard O-Ring Seat

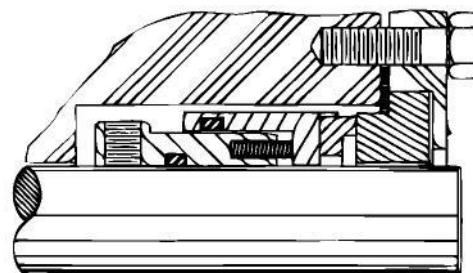

Standard "L" Shape Seat

Style 10

Versatile design for a wide range of services

The Style 10 is a multi-spring single faced rotary component seal. It can be mounted inside or outside the seal chamber or as a single or double seal arrangement. The Style 10 is not a repairable seal.

Benefits

- For use in small stuffing boxes or where multiple seals are needed
- Adaptable to many applications
- Reusable seal components
- Capable of handling a wide range of chemical applications

Features

- Compact construction
- Can be used inside or outside stuffing box, single or double
- Factory repairable
- Interchangeable secondary seals, Viton or TFE

Materials

- Metallurgy: 316SS
- Set screws: 316SS
- Springs: Hastelloy C*
- O-rings: fluoroelastomer standard
- Rotary face: chemical grade carbon standard, tungsten carbide optional

*Hastelloy C is a registered trademark of Haynes International.



Specifications

Pressure	To 250 psi (17 bar) mounted inside To 50 psi (3 bar) mounted outside
Temperature:	-20 F (-30 C) to 400 F (204 C)
Speed:	5,000 fpm (25.5 m/s)

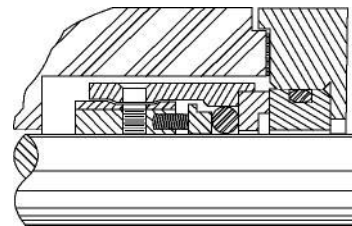

Style 10 inside mount

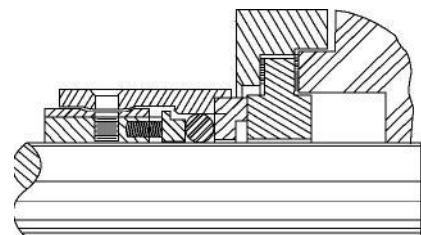

Style 10 outside mount

Style 16

Single outside rotary

The Type-16 is a balanced multi-spring outside mounted rotary seal. This design provides sealing without product contact with the metal seal parts. It is often used in chemical applications where the seal must be mounted on a non-metallic shaft. In these cases the Type-16 can be provided with a clamp type drive collar, otherwise a set-screw type driver is the standard. Repair kit available for easy repair.

Benefits

- Accessible for cleaning and resetting
- No measuring required
- Withstands up to 150 psi
- Suitable for plastic coated shafts
- Eliminates corrosion

Features

- Outside mounted
- Preset
- Balanced design
- Split drive collar option
- Metal parts isolated from media

Materials

- Metallurgy: 316SS
- Rotary face: chemical grade carbon, other options available
- Set screws: Hastelloy C*
- Springs: Hastelloy C*
- O-rings: Fluoroelastomer standard

*Hastelloy C is a registered trademark of Haynes International.



Specifications

Pressure	150 psi (10 bar)
Temperature:	400°F (204°C)
Speed:	2,500 fpm (12.7 m/s)

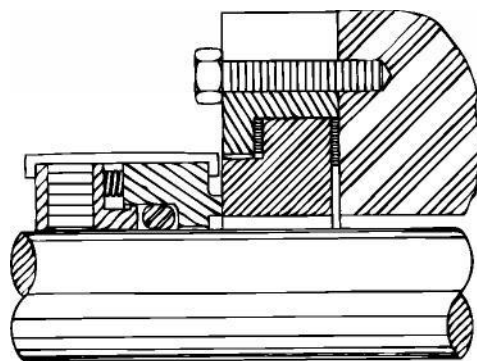

Style 60

Metal bellows rotary

The Type-60 is a single face metal bellows rotary seal designed for general service applications in chemical and light slurry applications. The Type-60 is available in various face and bellows materials, depending on the application requirements. Typically the metal bellows seal is not repairable.

Benefits

- Less heat generated at seal face
- No springs to clog
- Eliminates seal hang-up and fretting
- Optional metallurgies satisfy wide range of applications
- Compatible with most existing stuffing box designs

Features

- Inherently balanced
- Self-cleaning design
- No dynamic secondary seal
- Choice of bellows
- Small cross section

Materials

- Metallurgy: 316SS
- Rotary face: chemical grade carbon, other options available
- Set screws: Hastelloy C*
- Springs: Hastelloy C*
- O-rings: Fluoroelastomer standard

*Hastelloy C is a registered trademark of Haynes International.



Specifications

Pressure	300 psi (20 bar)
Vacuum	To 30" Hg (750mm Hg)
Temperature:	400°F (204°C)
Speed:	5,000 fpm (25.5 m/s)

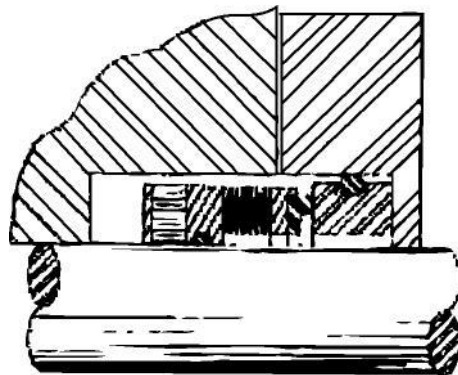

Style 65

High temperature metal bellows rotary

The Style 65 is similar to the Style 60, however it is designed to seal applications that exceed 400°F (204°C). It is able to seal high temperature primarily because it uses a graphite wedge as a secondary seal rather than an O-ring elastomer. Special metallurgy is often required for these kinds of applications. Typically the Style 65 is not repairable.

Benefits

- Less heat generated at seal face
- No springs to clog
- Eliminates seal hang-up and fretting
- Optional metallurgies satisfy wide range of applications
- Compatible with most existing stuffing box designs
- High temperature capability

Features

- Inherently balanced
- Self-cleaning design
- No dynamic secondary seal
- Choice of bellows
- Small cross section
- GRAPH-LOCK® secondary seal

Materials

- Metallurgy: 316SS, AM-350 bellows, Hastelloy C*
- Rotary face: chemical grade carbon, tungsten carbide optional
- Set screws: Hastelloy C*

*Hastelloy C is a registered trademark of Haynes International.

** GRAPH-LOCK is a registered trademark of Garlock, Inc.



Specifications

Pressure	300 psi (20 bar)
Vacuum	To 30" Hg (750mm Hg)
Temperature:	800 F (425 C)
Speed:	5,000 fpm (25.5 m/s)

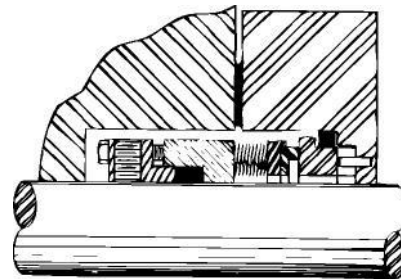

Stationaries

Klozure® offers a full range of stationery seats, including all standard designs, sizes and materials. In addition, Klozure offers non-standard shapes and sizes as well as additional materials including stainless steel, ni-resist, bronze and coated faces.

Type 01 Stationary

The o-ring stationary seats are designed to press-fit into a machined counter bore in a gland or pump housing. Before installing the o-ring, the gland counter bore and o-ring should be lubricated.

Type-02, Stationary “T” shaped stationary seat

The Type-02 seat is designed to be clamped into place by the gland follower against the pump housing. It is supplied with a gasket for each side of the hard stationary. The faces are available in a wide range of materials.



Type 04 Stationary (Cup-mounted) Seat

The Type-04 stationary seat is a cup-mounted stationary face. When installing the Type-04 seat, the cup and counter bore of the gland should be lubricated. The Type-04 is available in a wide range of face materials, however the material selection for elastomers is limited to Viton and Nitrile only.

Type-08 Stationary “L” Seat

The Type-08 stationary is a clamp mounted face. It has two gaskets provided, one for each side of the face, and should be clamped between the gland follower and the equipment housing. The Type-08 can be provided in a wide range of materials depending on the application requirements.



Materials

Silicon Carbide

Silicon carbide is the standard for Klozure in the majority of applications. Silicon carbide offers the widest range of chemical resistance of any face material readily available today. Additionally, it is extremely hard, giving it excellent abrasion resistance. Silicon carbide also offers the highest heat transfer characteristics essential for effective sealing of high temperature liquids. Available in three grades.

Ceramic

Ceramic has two advantages that make it the most commonly used seat material. It is nearly chemically inert and costs substantially less than other materials. Ceramic performs well in many applications. Other materials should be considered for thermally variable service such as hydro-carbon process applications or where elevated temperatures tend to vaporize media.

Tungsten Carbide

This is recommended for those hydro-carbon process applications destructive to ceramic materials. With good thermal shock properties, tungsten carbide also transmits heat well, minimizing media vaporization at seal faces. A hard, strong, metallic material, it easily withstands abrasive service.

Viking Pump Model No.	Shaft Size (Inches)	Seal Code No.	Adapter Code No.	P/S®-II Seal w/ Adapter Code No.	Adapter
G125	0.750	06-012-050-	JZ-012-001-	06-012-002-	Mandatory
H-HL 124	1.125	06-018-050-	JZ-018-002-	06-018-003-	Mandatory
H-HL 125	1.125	06-018-050-	JZ-018-004-	06-018-004-	Mandatory
H-HL 225	1.125	06-018-050-	JZ-018-004-	06-018-004-	Mandatory
J32	1.125	06-018-050-	JZ-018-004-	06-018-004-	Recommended
K-KR 32	1.125	06-018-050-	JZ-018-004-	06-018-004-	Recommended
HHL724	1.125	06-018-001	N/A	N/A	N/A
UNIV.H-HL	1.125	06-018-051-	JZ-018-003-	06-018-002-	Optional
L-LL/K-KK 4124/5	1.437	06-023-050-	JZ-023-005-	06-023-028-	Mandatory
L-LL-LQ 124	1.437	06-023-050-	JZ-023-006-	06-023-003	Mandatory
L-LL-LO 724	1.437	06-023-050-	JZ-023-003-	06-023-003-	Mandatory
L-LL 125	1.437	06-023-050-	JZ-023-003-	06-023-002-	Mandatory
L-LL 225	1.437	06-023-050-	JZ-023-003-	06-023-002-	Mandatory
LL 32	1.437	06-023-050-	JZ-023-003-	06-023-002-	Recommended
L-LO 32	1.437	06-023-050-	JZ-023-003-	06-023-002-	Recommended
LO 34	1.437	06-023-050-	JZ-023-003-	06-023-002-	Recommended
L-LL UNIV.	1.437	06-023-051-	JZ-023-002-	06-023-004-	Mandatory
K-KK 124	1.437	06-023-050-	JZ-023-006-	06-023-003-	Mandatory
K-KR 125	1.437	06-023-050-	JZ-023-003-	06-023-002-	Mandatory
K-KK 225	1.437	06-023-050-	JZ-023-003-	06-023-002-	Mandatory
K-KK 724	1.437	06-023-050-	JZ-023-003-	06-023-002-	Mandatory
K-KR UNIV.	1.437	06-023-051-	JZ-023-002-	06-023-004-	Mandatory
AK-AL 125	1.437	06-023-050-	JZ-023-003-	06-023-002-	Mandatory
LS 124	1.625	06-026-050-	JZ-026-001-	06-026-001-	Mandatory
LS 125	1.625	06-026-050-	JZ-026-001-	06-026-001-	Mandatory
LS 225	1.625	06-026-050-	JZ-026-001-	06-026-001-	Mandatory
LS UNIV.	1.625	06-026-051-	JZ-026-001-	06-026-002-	Optional
Q-M 34	1.937	06-031-050-	JZ-031-001-	06-031-001-	Optional
MR 124	2.437	06-039-050-	JZ-039-001-	06-039-001-	Mandatory
M 125	2.437	06-039-050-	JZ-039-001-	06-039-001-	Mandatory
M 225	2.437	06-039-050-	JZ-039-001-	06-039-001-	Mandatory
N 32	2.437	06-039-050-	JZ-039-002-	06-039-002-	Optional
N 34	2.437	06-039-050-	JZ-039-002-	06-039-002-	Optional
Q 124	2.437	06-039-010-	N/A	N/A	Piloted Gland
QR 124	2.437	06-039-050-	JZ-039-001-	06-039-001-	Mandatory
Q 125	2.437	06-039-050-	JZ-039-001-	06-039-001-	Mandatory
Q 4125	2.437	06-039-050-	JZ-039-001-	06-039-001-	Mandatory
Q 225	2.437	06-039-050-	JZ-039-001-	06-039-001-	Mandatory
Q-QS UNIV.	2.437	06-039-051-	JZ-039-001-	06-039-003-	Optional
N-R 333;335;337	3.437	06-055-050-	JZ-055-002-	06-055-002-	Optional
N-R 4335	3.437	06-055-050-	JZ-055-001-	06-055-001-	Optional
P 333;335;337	4.500	06-072-050-	JZ-072-001-	06-072-001-	Optional

Ordering P/S®-II seals for Viking Pumps

- Identify the pump model and from the table determine if a seal chamber adapter is optional or mandatory.
- If a seal chamber is required, use the product code in the "P/S®-II seal w/Adapter Code No." column.
- If the P/S®-II seal and seal chamber are ordered separately, use product codes in "Seal Code No." and "Adapter Code No." columns respectively.

Material Codes for Standard P/S®-II Seals

- | | | |
|---|---|---|
| <p>G060</p> <ul style="list-style-type: none"> • Black GYLON® Elements • PTFE Spacers • Fluoroelastomer O-rings • 316 Stainless Steel <p>G061</p> <ul style="list-style-type: none"> • Black GYLON® Elements • PTFE Spacers • EPR O-rings • 316 Stainless Steel | <p>G062</p> <ul style="list-style-type: none"> • Black GYLON® Elements • PTFE Spacers • KALREZ** O-rings • 316 Stainless Steel <p>G064</p> <ul style="list-style-type: none"> • Black GYLON® Elements • PTFE Spacers • AFLAS* O-rings • 316 Stainless Steel | <p>G936</p> <ul style="list-style-type: none"> • Black GYLON® Elements • PTFE Spacers • KALREZ/Fluoroelastomer O-rings • 316 Stainless Steel <p>G954</p> <ul style="list-style-type: none"> • Black GYLON® Elements • PTFE Spacers • KALREZ/AFLAS* O-rings |
|---|---|---|

*AFLAS is a trademark of Asahi Glass Company
 **KALREZ is a registered trademark of DuPont

Blackmer Pump Model No.	Pump Revision	Shaft Size (Inches)	Seal Code No.	P/S®-II Seal w/ Adapter Code No.	Transition Plate Code No.
SNP 1-1/4 & 1-1/2	-	0.875/1.000	06-014-052-	-	-
SNP2	-	1.000	06-016-052-	-	-
NP 1-1/2 [†]	-	1.062	06-017-006-	06-017-052-	6V-017-001-
NP 1-1/2 [†]	A & B	1.062	06-017-006-	06-017-052-	GV-017-001-
NP2 [†]	C & E	1.125	06-018-052-	-	-
SNP 2-1/2 ^{**}	-	1.125/1.375	06-018009-	-	-
NP2	A & B	1.187	06-019-002-	06-019-052-	GV-019-001-
NP 2-1/2	C & E	1.375	06-022-052-	-	-
NP3	C & E	1.375	06-022-052-	-	-
SNP3	A	1.375	06-022-052-	-	-
SNP3	-	1.375	06-022-052-	-	-
NP 2-1/2 [†]	A&B	1.437	06-023-052-	-	-
NP3	A & B	1.437	06-023-052-	-	-
MLN4 ^{**}	A&B	1.750/2.164	06-028-052-	-	-
NP4	C & E	2.125	06-034-052-	-	-
NP4	A & B	2.187	06-035-052-	-	-
SLN4	-	2.250	06-036-052-	-	-

*Transition plate must be used for these pump models. Select the P/S®-II seal with transition plate in the "P/S®-II Seal w/ Adapter Code No." column.

** Shaft is stepped.

Ordering P/S®-II seals for Blackmer Pumps

1. Identify the pump model and pump revision level.
2. Select the P/S®-II product code in "Seal Code No. column."
3. Seals showing a transition plate in "P/S®-II Seal w/ Trans. Plate Code No." column must be ordered this way the first time.

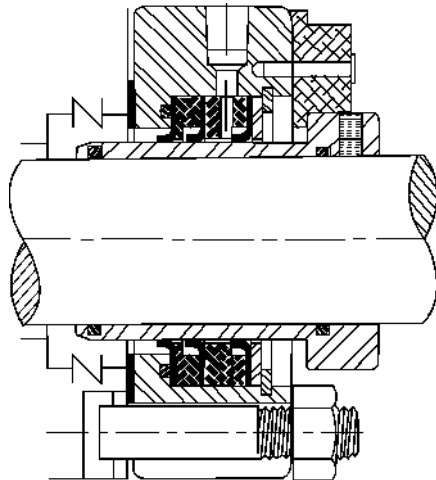

Material Codes for Standard P/S®-II Seals

G060

- Black GYLON® Elements
- PTFE Spacers
- Fluoroelastomer O-rings
- 316 Stainless Steel

G061

- Black GYLON® Elements
- PTFE Spacers
- EPR O-rings
- 316 Stainless Steel

G062

- Black GYLON® Elements
- PTFE Spacers
- KALREZ† O-rings
- 316 Stainless Steel

G064

- Black GYLON® Elements
- PTFE Spacers
- AFLAS†† O-rings
- 316 Stainless Steel

G936

- Black GYLON® Elements
- PTFE Spacers
- KALREZ/Fluoroelastomer O-rings
- 316 Stainless Steel

Material Codes for Transition Plate

- S000 316 Stainless Steel
- H000 HASTELLOY C‡
- A002 Alloy 20

†KALREZ is a registered trademark of DuPont

††AFLAS is a trademark of Asahi Glass Company

‡HASTELLOY C is a registered trademark of Haynes International.

Tuthill Global Gear Pump Model No.	Shaft Size (Inches)	P/S®-II Seal Code No.
GG 015	1.125"	06-018-025-
GG 030	1.125"	06-018-025-
GG 050	1.375"	06-022-027-
GG 070	1.375"	06-022-027-
GG 080	1.375"	06-022-027-
GG 090	1.375"	06-022-027-
GG 120	1.750"	06-028-029-
GG 130	1.750"	06-028-029-
GG 200	1.750"	06-028-029-
GG 210	1.750"	06-028-029-
GG 250		
GG 500		
GG 550		

Ordering P/S®-II seals for Tuthill Pumps

1. Identify the pump model and pump revision level.
2. Select the P/S®-II product code in "Seal Code No. column.

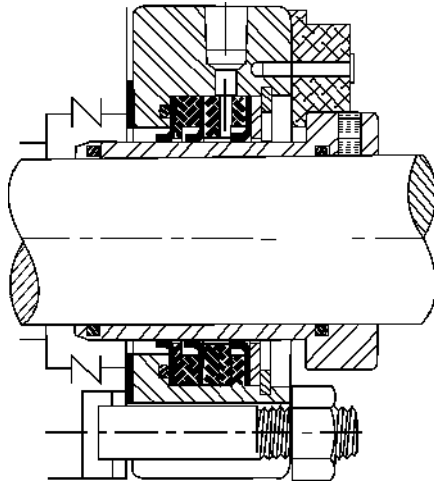

Material Codes for Standard P/S®-II Seals

- G060**
- 316 Stainless Steel
 - Black GYLON® Elements
 - PTFE Spacers
 - Fluoroelastomer O-rings
 - 316 Stainless Steel

- G061**
- Black GYLON® Elements
 - PTFE Spacers
 - EPR O-rings

- G062**
- Black GYLON® Elements
 - PTFE Spacers
 - KALREZ† O-rings
 - 316 Stainless Steel

Material Codes for Transition Plate

- S000 316 Stainless Steel
- H000 HASTELLOY C‡
- A002 Alloy 20

†KALREZ is a registered trademark of DuPont
 ††AFLAS is a trademark of Asahi Glass Company
 ‡HASTELLOY C is a registered trademark of Haynes International.

G064

- Black GYLON® Elements
- PTFE Spacers
- AFLAST†† O-rings
- 316 Stainless Steel

G936

- Black GYLON® Elements
- PTFE Spacers
- KALREZ/Fluoroelastomer O-rings
- 316 Stainless Steel

Desmi-Rotan Pump Model No.	Shaft Size (Inches)	P/S®-II Seal Code No.
26	20 MM	
33	20 MM	
41	25 MM	
51	35 MM	06-535-004-
66	36 MM	06-535-004-
81	50 MM	06-550-003-
101	50 MM	06-550-003-
126	60 MM	06-560-
151	60 MM	06-560-
152	70 MM	06-570-004-
201	85 MM	06-585-002-

Ordering P/S®-II seals for Desmi-Rotan Pumps

1. Identify the pump model and pump revision level.
2. Select the P/S®-II product code in "Seal Code No. column.

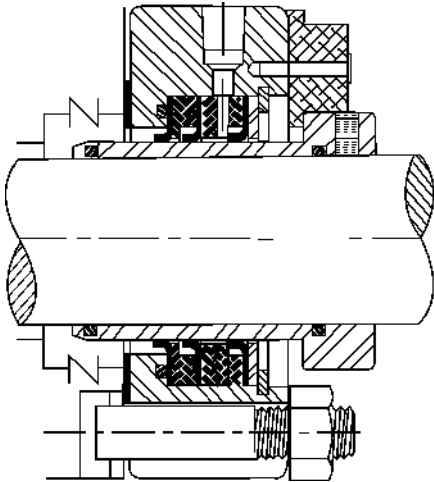

Material Codes for Standard P/S®-II Seals

- G060**
- 316 Stainless Steel
 - Black GYLON® Elements
 - PTFE Spacers
 - Fluoroelastomer O-rings
 - 316 Stainless Steel

- G061**
- Black GYLON® Elements
 - PTFE Spacers
 - EPR O-rings

- G062**
- Black GYLON® Elements
 - PTFE Spacers
 - KALREZ† O-rings
 - 316 Stainless Steel

Material Codes for Transition Plate

- S000 316 Stainless Steel
- H000 HASTELLOY C‡
- A002 Alloy 20

†KALREZ is a registered trademark of DuPont
 ††AFLAS is a trademark of Asahi Glass Company
 ‡HASTELLOY C is a registered trademark of Haynes International.

G064

- Black GYLON® Elements
- PTFE Spacers
- AFLAS^{††} O-rings
- 316 Stainless Steel

G936

- Black GYLON® Elements
- PTFE Spacers
- KALREZ/Fluoroelastomer O-rings
- 316 Stainless Steel

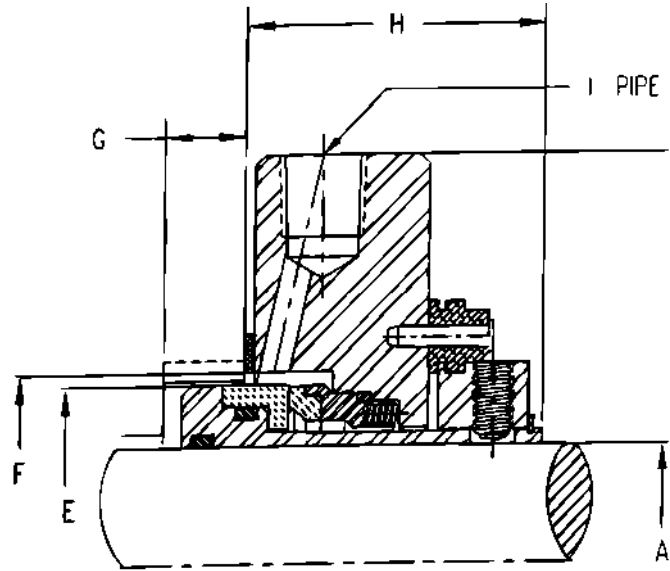
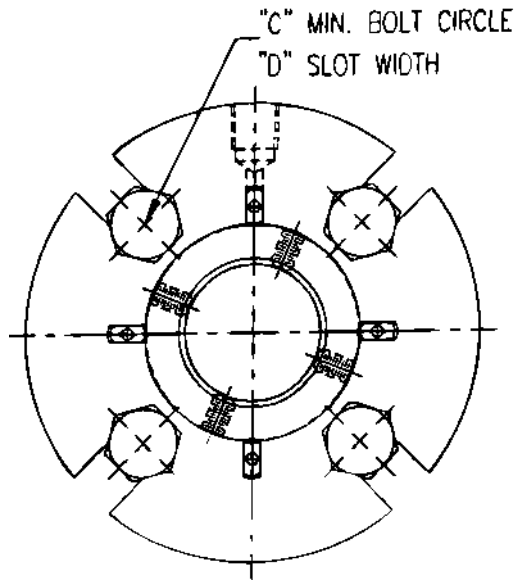

A Shaft Diameter +.000 - .002	B Gland OD	C Minimum Diameter Bolt Circle	D Slot Width	E GMP Rotary OD	F Box Bore		G Minimum Box Bore Depth	H Minimum First Obstr.	I Pipe Port
					Min.	Max.			
1"	4.000	2.750	0.437	1.575	1.625	2.000	0.500	1.875	1/4 NPT
1-1/8"	4.000	2.875	0.562	1.700	1.750	2.062	0.500	1.875	1/4 NPT
1-1/4"	4.000	3.000	0.562	1.825	1.875	2.187	0.500	1.875	1/4 NPT
1-3/8"	4.000	3.250	0.562	1.950	2.000	2.312	0.500	1.875	1/4 NPT
1-1/2"	5.000	3.375	0.562	2.200	2.250	2.500	0.500	1.875	1/4 NPT
1-5/8"	5.000	3.500	0.562	2.325	2.375	2.625	0.500	1.875	3/8 NPT
1-3/4"	5.500	3.625	0.562	2.450	2.500	2.750	0.500	1.875	3/8 NPT
1-7/8"	5.500	3.750	0.562	2.575	2.625	2.875	0.500	1.875	3/8 NPT
2"	5.500	3.875	0.562	2.700	2.750	3.000	0.500	1.875	3/8 NPT
2-1/8"	6.000	4.250	0.687	2.825	2.875	3.187	0.500	1.875	3/8 NPT
2-1/4"	6.500	4.500	0.687	2.950	3.000	3.375	0.500	1.875	3/8 NPT
2-3/8"	6.500	4.750	0.687	3.187	3.250	3.687	0.500	2.000	3/8 NPT
2-1/2"	6.500	5.000	0.687	3.312	3.375	3.937	0.500	2.000	3/8 NPT
2-5/8"	6.500	5.500	0.687	3.437	3.500	4.437	0.500	2.000	3/8 NPT
2-3/4"	7.000	6.000	0.687	3.625	3.750	4.875	0.500	2.000	3/8 NPT
2-7/8"	7.500	6.000	0.687	3.750	3.875	4.875	0.500	2.000	3/8 NPT
3"	7.500	6.000	0.812	3.875	4.000	4.812	0.500	2.000	3/8 NPT
3-1/4"	7.500	6.250	0.812	4.125	4.250	4.937	0.500	2.000	3/8 NPT
3-1/2"	8.500	6.500	0.812	4.375	4.500	5.187	0.500	2.000	3/8 NPT
3-3/4"	8.500	6.750	0.812	4.625	4.750	5.437	0.500	2.000	3/8 NPT
3-7/8"	8.500	6.750	0.812	4.750	4.875	5.437	0.500	2.000	3/8 NPT
4"	9.000	7.000	0.812	4.875	5.000	5.750	0.500	2.312	3/8 NPT
4-1/4"	9.000	7.250	0.812	5.125	5.250	6.000	0.500	2.312	3/8 NPT
4-1/2"	9.000	7.500	0.812	5.375	5.500	6.250	0.500	2.312	3/8 NPT
4-3/4"	9.250	8.000	0.812	5.625	5.750	6.562	0.500	2.312	3/8 NPT
5"	9.500	8.250	0.812	5.875	6.000	6.687	0.500	2.312	3/8 NPT

APPENDIX F — STYLE G M P - II DIMENSIONS

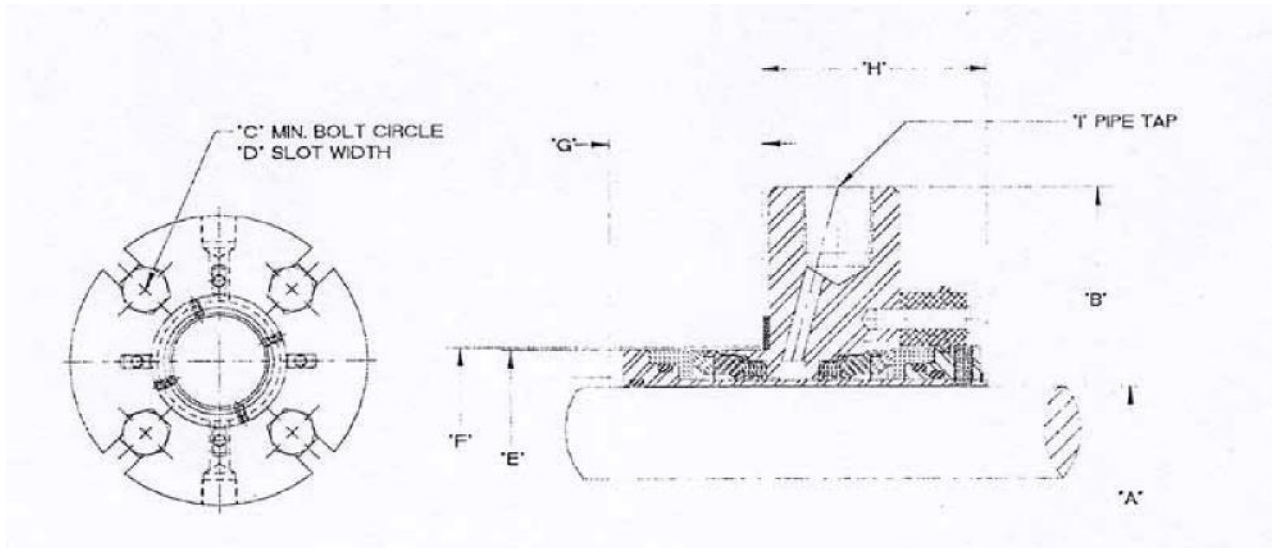

A Shaft Diameter +.000 - .002	B Gland OD	C Minimum Diameter Bolt Circle	D Slot	E GMP Rotary OD	F Box Bore		G Minimum Box Bore Depth	H Minimum First Obstr.	I Pipe Port
					Min.	Max.			
					Width				
1"	4.000	2.750	0.437	1.575	1.625	2.000	1.500	2.125	1/4 NPT
1-1/8"	4.000	2.875	0.562	1.700	1.750	2.062	1.437	2.125	1/4 NPT
1-1/4"	4.000	3.000	0.562	1.825	1.875	2.187	1.437	2.125	1/4 NPT
1-3/8"	4.000	3.250	0.562	1.950	2.000	2.312	1.437	2.125	1/4 NPT
1-1/2"	5.000	3.375	0.562	2.200	2.250	2.500	1.437	2.125	1/4 NPT
1-5/8"	5.000	3.500	0.562	2.325	2.375	2.625	1.437	2.125	3/8 NPT
1-3/4"	5.500	3.625	0.562	2.450	2.500	2.750	1.437	2.125	3/8 NPT
1-7/8"	5.500	3.750	0.562	2.575	2.625	2.875	1.437	2.125	3/8 NPT
2"	5.500	3.875	0.562	2.700	2.750	3.000	1.437	2.125	3/8 NPT
2-1/8"	6.000	4.250	0.687	2.825	2.875	3.187	1.437	2.125	3/8 NPT
2-1/4"	6.500	4.500	0.687	2.950	3.000	3.375	1.437	2.125	3/8 NPT
2-3/8"	6.500	4.750	0.687	3.187	3.250	3.687	1.687	2.250	3/8 NPT
2-1/2"	6.500	5.000	0.687	3.312	3.375	3.937	1.687	2.250	3/8 NPT
2-5/8"	6.500	5.500	0.687	3.437	3.500	4.437	1.687	2.250	3/8 NPT
2-3/4"	7.000	6.000	0.687	3.625	3.750	4.875	1.687	2.250	3/8 NPT
2-7/8"	7.500	6.000	0.687	3.750	3.875	4.875	1.687	2.250	3/8 NPT
3"	7.500	6.000	0.812	3.875	4.000	4.812	1.625	2.562	3/8NPT
3-1/4"	7.500	6.250	0.812	4.125	4.250	4.937	1.625	2.562	3/8 NPT
3-1/2"	8.500	6.500	0.812	4.375	4.500	5.187	1.625	2.562	3/8 NPT
3-3/4"	8.500	6.750	0.812	4.625	4.750	5.437	1.625	2.562	3/8 NPT
3-7/8"	8.500	6.750	0.812	4.750	4.875	5.437	1.625	2.875	3/8 NPT
4"	9.000	7.000	0.812	4.875	5.000	5.750	1.625	2.875	3/8 NPT
4-1/4"	9.000	7.250	0.812	5.125	5.250	6.000	1.625	2.875	3/8 NPT
4-1/2"	9.000	7.500	0.812	5.375	5.500	6.250	1.625	2.875	3/8 NPT
4-3/4"	9.250	8.000	0.812	5.625	5.750	6.562	1.625	2.875	3/8 NPT
5"	9.500	8.250	0.812	5.875	6.000	6.687	1.625	2.875	3/8 NPT

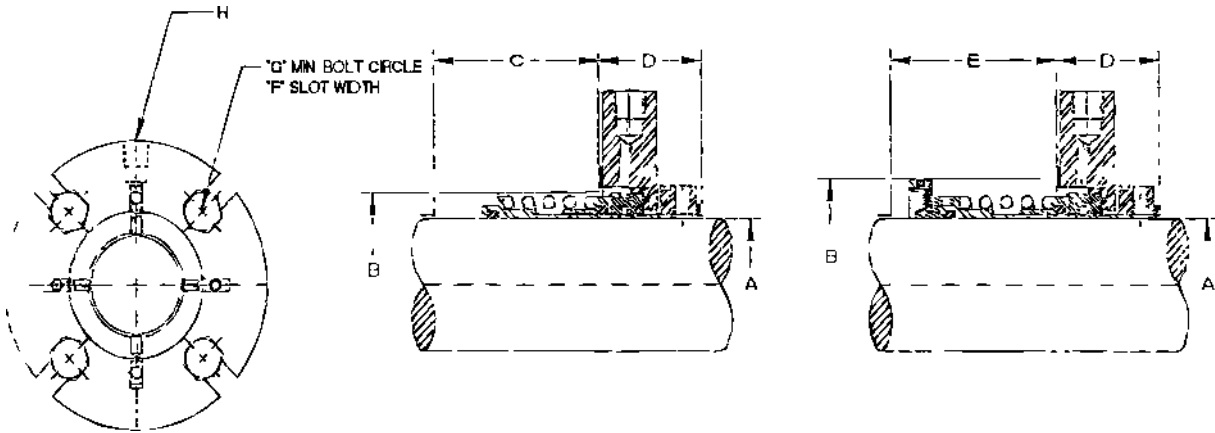

A	B	C	D	E	F	G	H
Shaft Diameter +.000 - .005	Minimum Bore Diameter	Minimum Box Depth	Minimum First Obstruction	Minimum Box Depth for "FS"	Slot Width	Minimum Bolt Circle	Pipe Port
1"	1.750	1.375	1.437	1.875	0.437	2.750	
1-1/8"	1.750	1.437	1.437	1.937	0.562	2.875	
1-1/4"	2.000	1.562	1.437	2.062	0.562	3.000	
1-3/8"	2.000	1.625	1.437	2.125	0.562	3.250	
1-1/2"	2.250	1.687	1.437	2.187	0.562	3.375	
1-5/8"	2.375	1.750	1.437	2.250	0.562	3.500	
1-3/4"	2.500	1.812	1.437	2.316	0.562	3.625	
1-7/8"	2.625	1.875	1.437	2.375	0.562	3.750	
2"	2.812	2.000	1.437	2.500	0.562	3.875	
2-1/8"	2.937	2.000	1.437	2.625	0.687	4.250	
2-1/4"	3.125	2.125	1.437	2.750	0.687	4.500	
2-3/8"	3.250	2.125	1.437	2.750	0.687	4.750	
2-1/2"	3.375	2.250	1.437	2.875	0.687	5.000	
2-5/8"	3.500	2.250	1.437	3.000	0.687	5.500	
2-3/4"	3.625	2.437	1.687	3.187	0.687	6.000	
2-7/8"	3.750	2.500	1.687	3.250	0.687	6.000	
3"					0.812		
3-1/8"					0.812		
3-1/4"					0.812		
3-3/8"					0.812		
3-1/2"					0.812		-
3-5/8"					0.812		
3-3/4"					0.812		
3-7/8"					0.812		
4"	3.875	2.500	1.687	3.250	0.812	6.000	

APPENDIX H — STYLE 1 9 / 2 0 DIMENSIONS

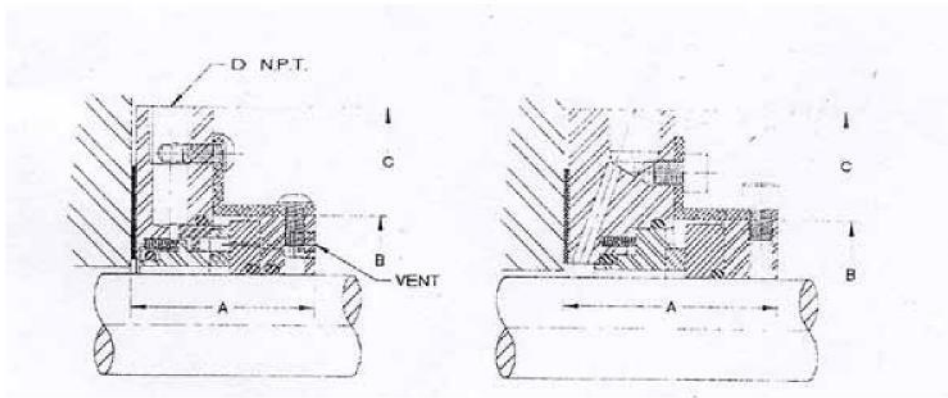

Shaft Diameter	A	B	C	D	E	F
	Operating Length	Rotary OD	Gland OD	Slot Width	Minimum Diameter Bolt Circle	Pipe Fitting
1/2"	2.250	1.875	3.980	0.437	2.625	1/4 NPT
5/8"	2.250	2.000	3.980	0.437	2.750	1/4 NPT
3/4"	2.250	2.125	3.980	0.437	2.875	1/4 NPT
7/8"	2.250	2.250	3.980	0.437	3.000	1/4 NPT
1"	2.250	2.375	4.980	0.437	3.125	1/4 NPT
1-1/8"	2.250	2.500	4.980	0.562	3.500	1/4 NPT
1-1/4"	2.250	2.625	4.980	0.562	3.625	1/4 NPT
1-3/8"	2.250	2.750	5.480	0.562	3.750	1/4 NPT
1-1/2"	2.250	2.875	5.480	0.562	3.875	1/4 NPT
1-5/8"	2.250	3.000	5.480	0.562	4.000	3/8 NPT
1-3/4"	2.250	3.125	5.980	0.562	4.125	3/8 NPT
1-7/8"	2.250	3.250	5.980	0.562	4.250	3/8 NPT
2"	2.250	3.375	5.980	0.562	4.375	3/8 NPT
2-1/8"	2.250	3.500	6.480	0.562	4.500	3/8 NPT
2-1/4"	2.250	3.625	6.480	0.687	4.875	3/8 NPT
2-3/8"	2.250	3.750	6.480	0.687	5.000	3/8 NPT
2-1/2"	2.250	3.875	6.480	0.687	5.125	3/8 NPT
2-5/8"	2.250	4.000	6.980	0.687	5.250	3/8 NPT
2-3/4"	2.250	4.125	6.980	0.687	5.375	3/8 NPT
2-7/8"	2.250	4.250	6.980	0.687	5.500	3/8 NPT
3"	2.375	4.375	7.980	0.812	5.625	3/8 NPT
3-1/8"	2.375	4.500	7.980	0.812	5.875	3/8 NPT
3-1/4"	2.375	4.625	8.480	0.812	6.000	3/8 NPT
3-3/8"	2.375	4.750	8.480	0.812	6.125	3/8 NPT
3-1/2"	2.375	4.875	8.980	0.812	6.250	3/8 NPT
3-5/8"	2.375	5.000	8.980	0.812	6.375	3/8 NPT
3-3/4"	2.375	5.125	9.480	0.812	6.500	3/8 NPT
3-7/8"	2.375	5.250	9.480	0.812	6.625	3/8 NPT
4"	2.375	5.375	9.980	0.812	6.750	3/8 NPT
4-1/8"	2.375	5.500	9.980	0.812	6.875	3/8 NPT
4-1/4"	2.375	5.625	10.480	0.812	7.000	3/8 NPT
4-3/8"	2.375	5.750	10.480	0.812	7.125	3/8 NPT
4-1/2"	2.375	5.875	10.980	0.812	7.250	3/8 NPT
4-5/8"	2.375	6.000	10.980	0.812	7.375	3/8 NPT
4-3/4"	2.375	6.125	11.480	0.812	7.500	3/8 NPT
4-7/8"	2.375	6.250	11.480	0.81215	7.625	3/8 NPT

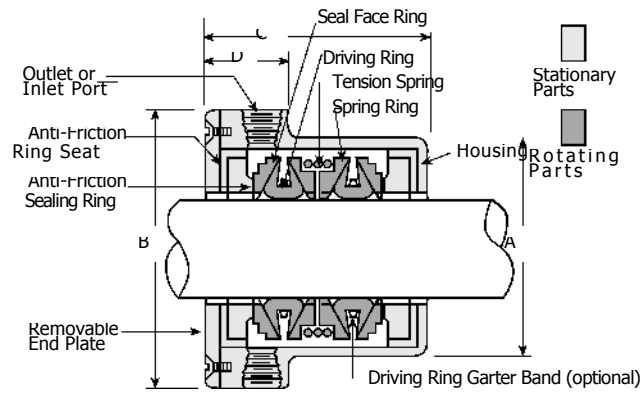

Dimensions (in.) and Weight (lbs)

Shaft Size Range	A	B	C	D	Unit Weight
1/2 to 11/16	1-1/2	2	1-3/4	13/16	1
3/4 to 15/16	1-3/4	2-1/4	2-1/8	13/16	1-1/4
1 to 1-3/16	2	2-1/2	2-1/8	13/16	1-1/2
1-1/4 to 1-7/16	2-1/4	3	1-1/8	13/16	1-3/4
1-1/2 to 1-11/16	2-1/2	3-1/4	2-1/8	13/16	2
1-3/4 to 1-15/16	3	3-3/4	2-1/4	13/16	2-1/2
2 to 2-3/16	3-1/4	4	2-3/8	13/16	3
2-1/4 to 2-7/16	3-1/2	4-1/4	2-3/8	13/16	3-1/4
2-1/2 to 2-11/16	3-3/4	4-1/2	2-7/16	13/16	3-1/2
2-3/4 to 2-15/16	4	5	2-1/2	13/16	4
3 to 3-3/16	4-3/8	5-1/2	2-3/4	13/16	5-3/4
3-1/4 to 3-7/16	4-3/4	5-3/4	2-3/4	7/8	6
3-1/2 to 3-11/16	5	6	2-3/4	7/8	6-1/2
3-3/4 to 3-15/16	5-3/8	6-3/8	2-7/8	7/8	7-1/2

APPENDIX J – STYLE P K DIMENSIONS

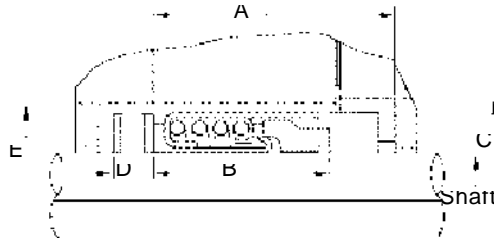

Shaft Diameter and Seal Size		A		B		C		D		E	
		Complete Seal Operating Length		Rotary Unit Operating Length		Gland Counter Bore		Stop Collar*		Min. Box Diameter	
Inches	mm	Inches	mm	inches	mm	inches	mm	inches	mm	inches	mm
3/8	9.5	1-1/4	31.8	7/8	22.2	1.000	25.4	5/16	7.9	1	25.4
7/16	11.1	1-1/4	31.8	7/8	22.2	1.125	28.6	5/16	7.9	1-1/16	27.0
1/2	12.7	1-1/4	31.8	7/8	22.2	1.125	28.6	5/16	7.9	1-1/16	27.0
9/16	14.3	1-1/4	31.8	7/8	22.2	1.250	31.8	5/16	7.9	1-1/4	31.8
5/8	15.9	1-1/4	31.8	7/8	22.2	1.250	31.8	5/16	7.9	1-3/16	33.3
11/16	17.5	1-1/4	31.8	7/8	22.2	1.375	34.9	5/16	7.9	1-3/8	34.9
3/4	19.1	1-1/4	31.8	7/8	22.2	1.375	34.9	5/16	7.9	1-3/8	34.9
13/16	20.6	1-1/4	31.8	7/8	22.2	1.500	38.1	5/16	7.9	1-1/2	38.1
7/8	22.2	1-1/4	31.8	7/8	22.2	1.500	38.1	5/16	7.9	1-1/2	38.1
15/16	23.8	1-3/8	34.9	1	25.4	1.625	41.3	5/16	7.9	1-5/8	41.3
1	25.4	1-3/8	34.9	1	25.4	1.625	41.3	5/16	7.9	1-5/8	41.3
1-1/16	27.0	1-3/8	34.9	1	25.4	1.750	44.5	5/16	7.9	1-21/32	42.1
1-1/8	28.6	1-3/8	34.9	1	25.4	1.750	44.5	5/16	7.9	1-21/32	42.1
1-3/16	30.2	1-9/16	39.7	1-3/16	30.2	2.000	50.8	5/16	7.9	1-15/16	49.2
1-1/4	31.8	1-9/16	39.7	1-3/16	30.2	2.000	50.8	5/16	7.9	2	50.8
1-5/16	33.3	1-9/16	39.7	1-3/16	30.2	2.125	54.0	3/8	9.5	2-1/16	52.4
1-3/8	34.9	1-9/16	39.7	1-3/16	30.2	2.125	54.0	3/8	9.5	2-1/8	54.0
1-7/16	36.5	1-5/8	41.3	1-1/4	31.8	2.250	57.2	3/8	9.5	2-3/16	55.6
1-1/2	38.1	1-5/8	41.3	1-1/4	31.8	2.250	57.2	3/8	9.5	2-1/4	57.2
1-9/16	39.7	1-5/8	41.3	1-1/4	31.8	2.375	60.3	3/8	9.5	2-5/16	58.7
1-5/8	41.3	1-5/8	41.3	1-1/4	31.8	2.375	60.3	3/8	9.5	2-3/8	60.3
1-11/16	42.9	1-5/8	41.3	1-1/4	31.8	2.500	63.5	3/8	9.5	2-7/16	61.9
1-3/4	44.5	1-5/8	41.3	1-1/4	31.8	2.500	63.5	3/8	9.5	2-1/2	63.5
1-13/16	46.0	1-5/8	41.3	1-1/4	31.8	2.625	66.7	3/8	9.5	2-9/16	65.1
1-7/8	47.6	1-5/8	41.3	1-1/4	31.8	2.625	66.7	3/8	9.5	2-5/8	66.7
1-15/16	49.2	1-3/4	44.5	1-3/8	34.9	2.750	70.0	3/8	9.5	2-11/16	68.3
2	50.8	1-3/4	44.5	1-3/8	34.9	2.750	70.0	3/8	9.5	2-3/4	70.0
2-1/8	54.0	1-3/4	44.5	1-3/8	34.9	2.875	73.0	3/8	9.5	2-7/8	73.0
2-1/4	57.2	1-3/4	44.5	1-3/8	34.9	3.000	76.2	3/8	9.5	3	76.2
2-3/8	60.3	1-3/4	44.5	1-3/8	34.9	3.125	79.4	3/8	9.5	3-1/8	79.4
2-1/2	63.5	1-3/4	44.5	1-3/8	34.9	3.250	82.6	3/8	9.5	3-1/4	82.6
2-5/8	66.7	1-7/8	47.6	1-1/2	38.1	3.375	85.7	3/8	9.5	3-3/8	85.7
2-3/4	70.0	1-7/8	47.6	1-1/2	38.1	3.500	88.9	3/8	9.5	3-1/2	88.9
2-7/8	73.0	1-7/8	47.6	1-1/2	38.1	3.625	92.1	3/8	9.5	3-5/8	92.1
3	76.2	1-7/8	47.6	1-1/2	38.1	3.750	95.3	3/8	9.5	3-3/4	95.3

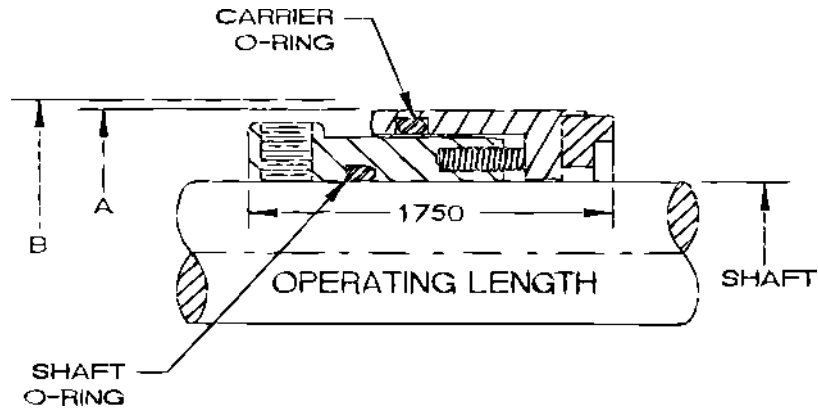

Shaft Diameter +.000 - .002	A	B	C	
	Rotary Unit	Minimum Bore Diameter	O-Rings	
			Shaft	Carrier
1"	1.580	1.750	120	126
1-118"	1.705	1.875	122	128
1-1/4"	1.830	2.000	124	130
1-3/8"	1.955	2.125	126	132
1-7/16"	2.017	2.375	127	134
1-1/2"	2.080	2.375	128	134
1-518	2.265	2.500	130	136
1-3/4"	2.390	2.625	132	138
1-718	2.515	2.750	134	140
2"	2.640	3.000	136	142
2-1/8"	2.765	3.125	138	144
2-1/4"	2.890	3.250	140	146
2-3/8"	3.086	3.375	229	232
21/20	3.211	3.375	230	233
2-5/8"	3.336	3.500	231	234
2-3/4"	3.461	3.750	232	235
2-7/8"	2.586	3.875	233	236
3"	3.711	4.000	234	237
3-118"	3.836	4.125	235	238
3-1/4"	3.961	4.250	236	239
3-3/8"	4.086	4.375	237	240
3-1/2"	4.211	4.500	238	241
3-5/8"	4.336	4.625	239	242
3-3/4"	4.461	4.750	240	243
3-718'	4.586	4.875	241	244
4"	4.711	5.000	242	245

APPENDIX L — STYLE 1 0 DIMENSIONS

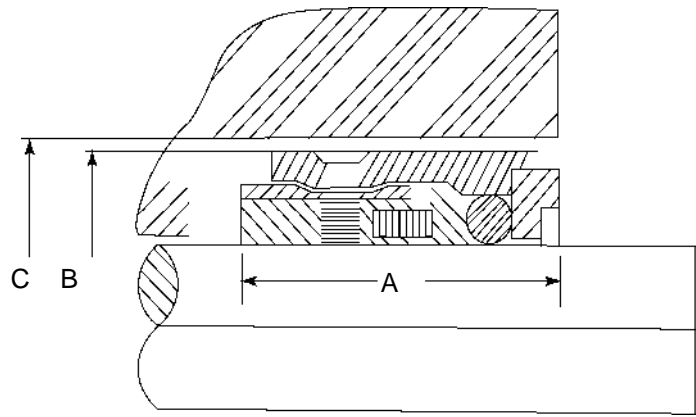

Shaft Diameter +.000 - .002	A	B	C	O-Ring Size
	Operating Length	Seal OD	Minimum Bore	
1/2"	0.750	0.937	1.156	112
5/8"	0.750	1.062	1.312	114
3/4"	0.875	1.187	1.437	210
7/8"	0.937	1.312	1.562	212
1"	1.000	1.437	1.750	214
1-1/8"	1.000	1.562	1.750	216
1-1/4"	1.000	1.687	2.000	218
1-3/8"	1.125	1.812	2.000	220
1-1/2"	1.125	1.937	2.250	222
1-5/8"	1.125	2.062	2.500	223
1-3/4"	1.375	2.312	2.500	327
1-7/8"	1.375	2.500	2.625	328
2"	1.375	2.625	2.875	329
2-1/8"	1.687	2.750	3.125	330
2-1/4"	1.375	2.844	3.250	331
2-3/8"	1.687	3.000	3.375	332
2-1/2"	1.375	3.125	3.500	333
2-5/8"	1.687	3.250	3.625	334
2-3/4"	1.687	3.375	3.750	335
2-7/8"	1.687	3.500	3.875	336
3"	1.687	3.625	4.000	337
3-1/8"	1.687	3.750	4.062	338
3-1/4"	1.687	3.875	4.250	339
3-3/8"	1.687	4.000	4.375	340
3-1/2"	1.687	4.125	4.500	341
3-5/8"	1.687	4.250	4.625	342
3-3/4"	1.687	4.375	4.750	343
3-7/8"	1.687	4.500	4.875	344
4"	1.687	4.625	5.000	345
4-1/8"	1.687	4.875	5.250	346
4-1/4"	1.687	5.000	5.375	347.
4-3/8"	1.687	5.125	5.500	348
4-1/2"	1.687	5.250	5.625	349
4-5/8"	1.687	5.375	5.750	349

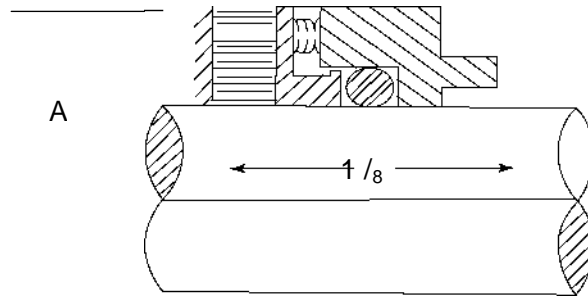

Shaft Diameter +.000 - .002	A	O-Ring Size
	Seal OD	
3/4"	1.625	210
7/8"	1.750	212
1"	1.875	214
1-1/8"	2.000	216
1-1/4"	2.125	218
1-3/8"	2.250	220
1-1/2"	2.375	222
1-5/8"	2.500	223
1-3/4"	2.625	224
1-7/8"	2.750	225
2"	2.875	226
2-1/8"	3.000	227
2-1/4"	3.125	228
2-3/8"	3.250	229
2-1/2"	3.375	230
2-5/8"	3.500	231
2-3/4"	3.625	232
2-7/8"	3.750	233
3"	3.875	234
3-1/8"	4.000	235
3-1/4"	4.125	236
3-3/8"	4.250	237
3-1/2"	4.375	238
3-5/8"	4.500	239
3-3/4"	4.625	240
3-7/8"	4.750	241
4"	4.875	242

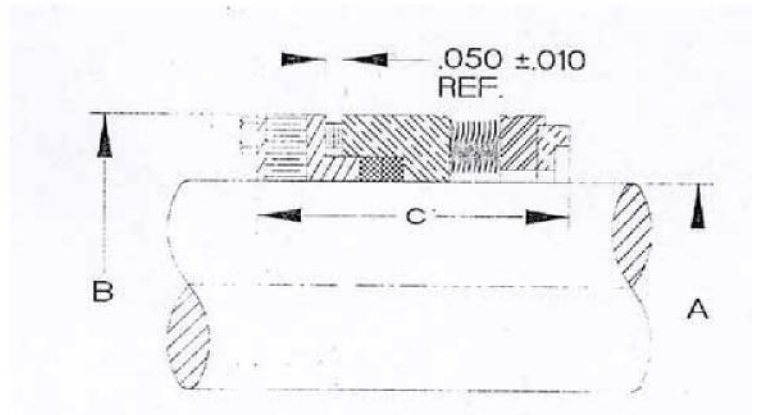
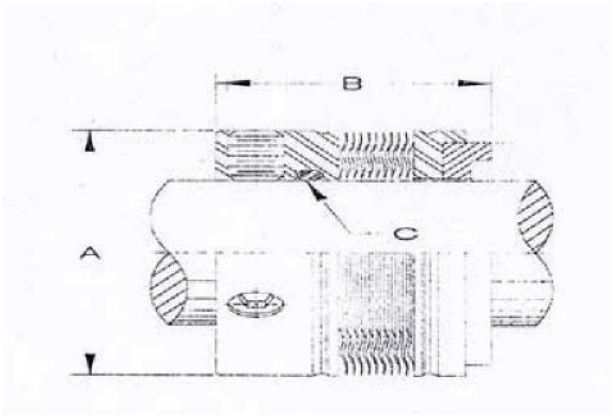

Shaft Diameter +.000 - .002	A	B	O-Ring Size
	Seal OD	Operating Length	
3/4"	1.312	1.250	116
7/8"	1.437	1.250	118
1"	1.562	1.250	120
1-1/8"	1.687	1.250	122
1-1/4"	1.812	1.312	124
1-3/8"	1.937	1.437	126
1-1/2"	2.062	1.437	128
1-5/8"	2.187	1.437	130
1-3/4"	2.312	1.437	132
1-7/8"	2.437	1.500	134
2"	2.562	1.500	136
2-1/8"	2.687	1.500	138
2-1/4"	2.812	1.562	140
2-3/8"	2.937	1.562	142
2-1/2"	3.187	1.562	144
2-5/8"	3.312	1.625	146
2-3/4"	3.437	1.625	148
2-7/8"	3.625	1.687	150
3"	3.750	1.687	151
3-1/8"	3.875	1.750	235
3-1/4"	4.000	1.750	236
3-3/8"	4.125	1.750	237
3-1/2"	4.250	1.875	238
3-5/8"	4.375	1.875	239
3-3/4"	4.500	1.875	240
3-7/8"	4.625	1.875	241
4"	4.750	1.875	242

A	B	C
Shaft Diameter +.000 - .002	Seal OD	Operating Length
0.750	1.312	1.250
0.875	1.437	1.250
1.000	1.562	1.250
1.125	1.687	1.250
1.250	1.812	1.250
1.375	1.937	1.437
1.500	2.062	1.437
1.625	2.187	1.437
1.750	2.312	1.437
1.875	2.437	1.500
2.000	2.562	1.500
2.125	2.687	1.500
2.250	2.812	1.562
2.375	2.937	1.562
2.500	3.187	1.562
2.625	3.312	1.625
2.750	3.437	1.625
2.875	3.625	1.687
3.000	3.750	1.687
3.125	3.875	1.750
3.250	4.000	1.750
3.375	4.125	1.750
3.500	4.250	1.875
3.625	4.375	1.875
3.750	4.500	1.875
3.875	4.625	1.875
4.000	4.750	1.875

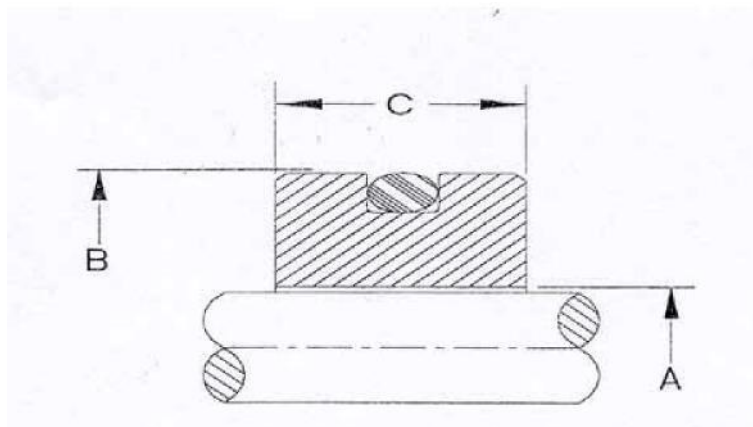

A	B	C	D
Shaft Diameter +.000 - .002	Bore Diameter +.005 -.000	Seat Width	O-Ring Size
1/2"	1.000	.312	117
5/8"	1.250	.406	214
3/4"	1.375	.406	216
7/8"	1.500	.406	218
1"	1.625	.437	220
1-1/8"	1.750	.437	222
1-1/4"	1.875	.437	223
1-3/8"	2.000	.437	224
1-1/2"	2.125	.437	225
1-5/8"	2.375	.500	227
1-3/4"	2.500	.500	228
1-7/8"	2.625	.500	229
2"	2.750	.500	230
2-1/8"	3.000	.560	232
2-1/4"	3.125	.560	233
2-3/8"	3.250	.560	234
2-1/2"	3.375	.560	235
2-5/8"	3.375	.625	235
2-3/4"	3.500	.625	236
2-7/8"	3.750	.625	238
3"	3.875	.625	239
3-1/8"	4.000	.625	240
3-1/4"	4.125	.625	241
3-3/8"	4.250	.625	242
3-1/2"	4.375	.625	243
3-5/8"	4.500	.781	244
3-3/4"	4.625	.781	245
3-7/8"	4.750	.781	246
4"	4.875	.781	247

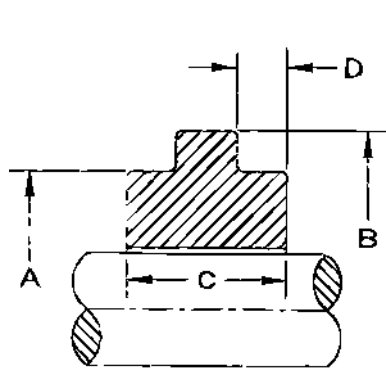

STYLE 02

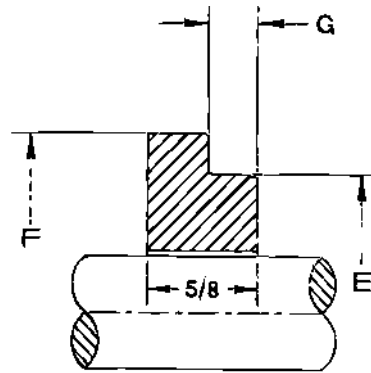

STYL F 08

Style 02					Style 08	
Shaft Diameter +.000 - .002	A	B	C	D	E	F
	Seal OD	Operating Length	Seat Width	Step Width	Minimum Bore Diameter	Minimum Bore Diameter
5/8"	--	--	--	--	--	--
3/4"	1.437	1.875	0.750	0.375		
7/8"	1.562	1.875	0.750	0.375	1.500"	1.937"
1"	1.625	2.062	0.8120.437		1.625"	2.125"
1-1/8"	1.750	2.187	0.8120.437		1.750"	2.250"
1-1/4"	2.000	2.437	0.8120.437		1.875"	2.375"
1-3/8"	2.000	2.437	0.875	0.500	2.000"	2.437"
1-1/2"	2.250	2.812	0.875	0.500	2.250"	2.750"
1-5/8"	2.462	2.656	0.875	0.500	2.375"	2.875"
1-3/4"	2.500	3.062	0.875	0.500	2.500"	3.125"
1-7/8"	2.625	3.187	1.000	0.625	2.625"	3.250"
2"	2.875	3.437	1.000	0.625	2.750"	3.500"
2-1/8"	2.906	3.437	1.000	0.625	2.875"	3.750"
2-1/4"	3.250	3.812	1.000	0.625	3.000"	3.875"
2-3/8"	3.375	3.937	1.000	0.625	3.125"	3.937"
2-1/2"	3.500	4.062	1.000	0.625	3.250"	4.125"
2-5/8"	3.625	4.187	1.000	0.625	3.375"	4.250"
2-3/4"	3.750	4.312	1.000	0.625	3.500"	4.375"
2-7/8"	3.875	4.437	1.000	0.625	3.625"	4.562"
3"	4.000	4.562	1.000	0.625	3.750"	4.625"

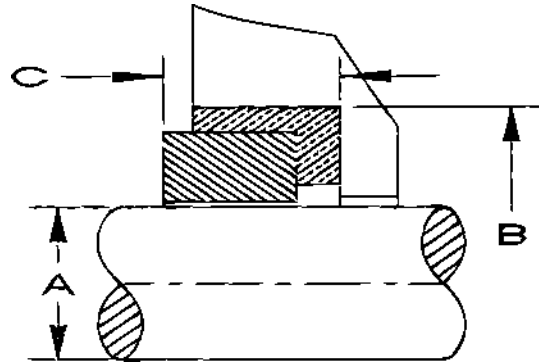

A	B	C
Shaft Diameter +.000 - .002	Bore Diameter ±.005	Seat Width
1/2"	1.125	0.375
5/8"	1.250	0.375
3/4"	1.375	0.375
7/8"	1.500	0.375
1"	1.625	0.375
1-1/8"	1.750	0.375
1-1/4"	2.000	0.375
1-3/8"	2.125	0.375
1-1/2"	2.250	0.375
1-5/8"	2.375	0.375
1-3/4"	2.500	0.375
1-7/8"	2.625	0.375
2"	2.750	0.375
2-1/8"	2.875	0.375
2-1/4"	3.000	0.375
2-3/8"	3.125	0.375
2-1/2"	3.250	0.375
2-5/8"	3.375	0.375
2-3/4"	3.500	0.375
2-7/8"	3.625	0.375
3"	3.750	0.375

APPENDIX S — STOP COLLAR DIMENSIONS

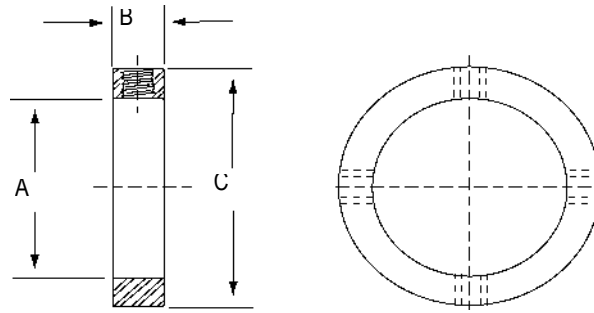

A	B	C
Shaft Diameter +.000 - .002	Width	OD
3/8"	5/16"	0.750
7/16"	5/16"	0.812
1/2"	5/16"	0.875
9/16"	5/16"	0.937
5/8"	5/16"	1.000
11/16"	5/16"	1.062
3/4"	5/16"	1.125
13/16"	5/16"	1.187
7/8"	5/16"	1.250
15/16"	5/16"	1.312
1"	5/16"	1.375
1-1/16"	5/16"	1.437
1-1/8"	5/16"	1.500
1-3/16"	5/16"	1.562
1-1/4"	5/16"	1.625
1-5/16"	3/8"	1.812
1-3/8"	3/8"	1.875
1-7/16"	3/8"	1.937
1-1/2"	3/8"	2.000
1-9/16"	3/8"	2.062
1-5/8"	3/8"	2.125

A	B	C
Shaft Diameter +.000 - .002	Width	OD
1-11/16"	3/8"	2.187
1-3/4"	3/8"	2.250
1-13/16"	3/8"	2.312
1-7/8"	3/8"	2.375
1-15/16"	3/8"	2.437
2"	3/8"	2.500
2-1/8"	3/8"	2.625
2-1/4"	3/8"	2.750
2-3/8"	3/8"	2.875
2-1/2"	3/8"	3.000
2-5/8"	3/8"	3.125
2-3/4"	3/8"	3.250
2-7/8"	3/8"	3.375
3"	3/8"	3.500

Glossary of Terms and Definitions

ACTUAL FACE PRESSURE: The true unit pressure exerted upon the primary sealing elements less the effect of the pressure wedge. The resultant of axial closing and opening forces acting on the primary sealing elements at the seal faces. This would include spring pressure.

ANSI: American National Standards Institute.

ANTI-EXTRUSION RING: A ring which is installed on the low pressure side of an O-ring or similar seal to prevent extrusion of the sealing material.

ANTI-ROTATION DEVICE: A device such as a key, or pin, used to prevent rotation of one component relative to an adjacent component in a seal assembly.

ASPERITIES: Minute imperfections on the seal face of the mating ring which are the result of normal surface finishing processes.

ATMOSPHERIC ABRASIVE: An abrasive which is formed by the crystallization or oxidation of a fluid exposed to the atmosphere.

AXIAL MOVEMENT: Movement along the axis or parallel to the center line of a shaft.

BACK-UP RING: See Anti-Extrusion Ring.

BALANCE DIAMETER: In a face seal, the diameter which defines the limit of the area exposed to sealed fluid pressure which is transmitted to the seal faces as closing force. In a seal with a sliding secondary seal (O-ring, U-cup, wedge, etc.), the diameter on which the secondary seal slides; in a bellows seal, the effective diameter of the bellows.

BALANCED SEAL: A mechanical seal arrangement whereby the hydraulic pressure in the seal chamber has its effect on the seal faces substantially reduced through seal design.

BARRIER FLUID: See Buffer Fluid.

BELLEVILLE WASHER: A washer which has a slightly conical shape and acts as a spring when compressed axially.

BELLOWS CONVOLUTION: In a welded bellows an assembly of two single-ply or multiple-ply formed plates or diaphragms, welded at either the inner diameters or the outer diameters. In a formed bellows, a one-piece, thin-walled, single-ply or multiple-ply, ring-like member having a deep fold or corrugation, generally of "U"-shaped section.

BELLOWS DAMPER: A device used for damping vibration. One type consists of a simple metal member which is spring loaded against some exterior portion of the bellows, or against the attached primary seal or its carrier.

BELLOWS DIAPHRAGM: See Bellows Plate.

BELLOWS PITCH: The distance between convolutions.

BELLOWS PLATE: A single, thin, metallic disc. When adjacent disks are alternately welded together at their inner and outer edges, they form the bellows assembly. Also called Bellows Diaphragm.

BELLOWS SEAL: A type of mechanical seal which utilizes a welded or formed bellows to provide secondary sealing and spring loading.

BIDIRECTIONAL PRESSURE SEAL: Also called Reversible Balanced or Double Balanced Seal. A seal which is designed to seal equally well when the pressure is applied from either direction.

BUFFER FLUID: A fluid which is introduced between two seal elements, quite often at a pressure which is higher than the pressure of the fluids on either side of the seal assembly. Also called a Barrier Fluid.

BUSHING: A square or rectangular cross section device used to restrict flow between (A) two different fluids, (B) liquid to gas, (C) a hot fluid from a cool fluid, (D) a clean fluid from a dirty fluid.

BYPASS: An environmental control whereby a line is taken from

the pump case into the seal chamber to permit fluid flow through the seal chamber.

CARBONIZATION: Oxidation of hydrocarbons, resulting in the formation of carbonaceous residue.

CARTRIDGE SEAL: A completely self-contained assembly including primary and secondary seals, gland, and sleeve, usually needing no installation measurement. The result is a convenient unit which can be inserted in a properly sized recess in a pump or similar device.

CASCADED SEALS: Seals which are staged or arranged in series and which have a regulated pressure between adjacent pairs.

CAVITATION: A condition in which vapor or gas bubbles occur locally in liquids, normally in an area where pressure decreases abruptly. The subsequent collapse of the bubbles causes high local impact pressure which can contribute to equipment wear and reduced seal life.

CENTRIFUGAL SEPARATOR: A device utilizing centrifugal force to separate impurities or abrasive solids from the fluid. Generally used with a connection to the volute of the pump, allowing the abrasive fluid to pass through the separator, discharging a relatively clean fluid from the top of the separator into the seal chamber.

CIRCULATION CONNECTIONS: The inlet and outlet ports of the seal cavity or seal gland which receive the piping or tubing for circulating liquid in close proximity to the mechanical seal faces.

CLOGGING: The condition in a mechanical seal where foreign materials and suspended solids interfere with the free movement of any movable device.

COIL SPRING: A type of spring which is formed from wire wrapped in a helix. The spring so formed encloses a volume in the shape of a right cylinder. It is used as a single or in multiples transmitting a uniform closing force on the seal face.

DEAD ENDED: A seal chamber having no circulation.

DIFFERENTIAL PRESSURE: A difference in pressure between two points in a system, such as one point immediately upstream of a seal and the other immediately downstream.

DILUTION RATE: The rate at which a liquid flush migrates into the product fluid.

DOUBLE SEAL: Two mechanical seals mounted back-to-back, face-to-face, or tandem, designed to permit a liquid or gas buffer fluid between the two seals.

DRY FACE SEAL: One which effectively seals without the need for a liquid film between the faces.

DRY-RUNNING: Running without a liquid film between the sealing faces.

END PLATE: A plate which holds the nonrotating assembly of a mechanical seal and connects it to the seal chamber. Also called gland plate or flange.

EXTERNALLY PRESSURIZED SEAL: A seal that has pressure acting on the seal parts from an independent source of supply.

FACE COATINGS: Various dense materials applied to the surface of base materials to increase wear characteristics of the seal face. See Hard Facing.

FACE PRESSURE: The face load, computed as the sum of the pneumatic or hydraulic force and the spring force, divided by the contacting area of the sealing face or lip. For lip seals and packings, the face load also includes the interference load.

FACE SEAL: A device which prevents leakage of fluids along rotating shafts. Sealing is accomplished by a stationary primary seal ring bearing against the face of a mating ring mounted on a shaft. Axial spring force and fluid pressure maintains the contact between seal ring and mating ring. Also called mechanical seal.

FACE SQUARENESS (Lack of): The deviation from 90° of the seal face's angle to the true axis of the shaft.

FILM THICKNESS: In a dynamic seal, the distance separating the two surfaces which form the primary seal.

FLASH: Imperfections on the elastomeric portion of a seal, formed by extrusion of the elastomer at the parting lines in the mold cavity.

FLASHING: A rapid change in fluid state from liquid to gas. In a dynamic seal, this can occur when frictional energy is added to the fluid as the latter passes between the primary sealing faces, or when fluid pressure is reduced below the fluid's vapor pressure because of a pressure drop across the sealing faces.

FLATNESS: A measurement of surface finish of a seal face, usually expressed in helium light bands (1 helium light band = 0.0000115" or 0.00029mm).

FLEXIBLE MEMBERS: That portion of a seal containing springs or a bellows.

FLOATING MEMBER OR ELEMENT: (1) The seal member of a rotary mechanical seal face which is flexibly loaded. (2) An annular leaf spring activated member which rides under compression between the stationary and drive faces of a dry face seal.

FLUSH: A small amount of fluid which is introduced into the seal chamber in close proximity to the sealing faces and usually used for cooling or other protection of the seal faces.

FORMED METAL BELLOWS: A metal bellows formed by hydro-forming or rolling.

FREE LENGTH: The uncompressed axial length of a face seal assembly, spring, or a bellows.

FRETTING: A combination of corrosion and wear which occurs when a secondary seal continually wipes the protective oxide coating from a shaft or sleeve.

GLAND FOLLOWER (PACKING): The axially movable part of a stuffing box which is forced against the packing by means of a manual adjustment, resulting in an increase in radial sealing force.

GLAND PLATE (OR GLAND): See End Plate.

HAMMER, WATER: The sound of concussion when a flowing liquid is suddenly stopped.

HARD FACE: A seal face, either stationary or rotating element, made of or coated with a material of high hardness. Common hard face materials are: Tungsten Carbide, Stellite, Ceramic, Silicon Carbide.

HARD FACING: A process by which a material of high hardness is applied to a softer material such as by flame spraying, plasma spraying, or electroplating. Hard facing can also be achieved by nitriding, carburizing or welding.

HARMONIC RESONANCE: A rhythmic harmonic motion having a specific vibration frequency.

HEAT CHECK: Heat checking is a condition of minute radial cracks on the surface of a hard seal face. High temperatures at the seal faces cause the surface material to expand at a greater rate than the subsurface material, causing minute cracks in the surface.

HYDRAULIC BALANCE: It is defined as the ratio of two areas: The area of the sealing face which is bounded by the balance diameter and the outside diameter of the sealing face, and the area which is bounded by the outer and inner diameters of the sealing face.

INITIAL SPRING TENSION: The tension in a spring at the correct setting of the seal at initial seal installation.

INSIDE MOUNTED SEAL: A mechanical seal with its seal head mounted inside the cavity which holds the fluid to be sealed.

LAPPING: A finishing operation using small free-floating abrasives in a fluid on a flat surface, or diamond charged plates. Used to produce extremely smooth and flat surface on a mechanical seal face. See Flatness.

LEAKAGE RATE: The quantity of fluid passing through a seal in a given length of time. For compressible fluids, it is normally expressed in standard cubic feet per hour (SCFH), and for incompressible fluids, in terms of cubic centimeters per unit of time.

MAGNETIC SEAL: A seal which uses magnetic material, instead of springs or a bellows, to provide the closing force to keep the seal faces together.

MATING RING: A disc or ring-shaped member, mounted either on a shaft or in a housing, which provides the primary seal when in proximity to the face of an axially adjustable face seal assembly.

METAL FATIGUE: A condition usually caused by repeated bending and flexing of a metal part, and resulting in fracture of the metal.

MINIMUM COMPRESSED LENGTH: The length of a spring, bellows, or face seal assembly which has been loaded to its solid (minimum) height.

OPERATING LENGTH: For an installed face seal assembly, the axial distance from the seal face to a reference plane, usually the inward most part of the seal. The term is also applied to the dimensional range within which a seal can safely be operated.

OPPOSED DOUBLE SEALS: Two seals which are so arranged that they face each other. In this arrangement, the two seal heads usually ride against the faces of a common mating ring. Also called Face-to-Face Double Seals.

OPTICAL FLAT: A transparent disc, usually of fused quartz, which has been lapped flat and polished to less than one light band flatness on one face, or on both faces. It is used to measure flatness in conjunction with a monochromatic light source.

OUTSIDE MOUNTED SEAL: A mechanical with its seal head mounted outside the cavity which holds the fluid to be sealed.

PACKING: Any variety of materials such as carbon, cotton, hemp, or synthetic materials, for fitting into a stuffing box. The packing is used to make sealing contact with the shaft to be sealed by adjustment of a gland which compresses the material against the face and bore of the stuffing box.

PITTING: Surface voids usually caused by mechanical erosion, chemical corrosion, or cavitation.

PRESSURE GRADIENT: The pressure drop which occurs across seal faces ranging from the seal chamber pressure to atmospheric pressure. It is usually illustrated by means of a wedge.

PRESSURE GRADIENT FACTOR (K FACTOR): When multiplied with the fluid pressure being sealed, it gives the average pressure that acts on the face area tending to open the seal.

PRIMARY LEAKAGE: Leakage of a mechanical seal, with the fluid escaping from the region between the faces of the primary sealing elements.

PRIMARY SEAL: The seal faces.

PUMPING RING: A simplified impeller within a chamber which circulates fluid for cooling purposes.

PUSHER TYPE SEAL: A mechanical seal in which a secondary seal is pushed along the shaft or sleeve to compensate for face wear.

PV FACTOR: The product of face pressure and relative sliding velocity. The units customarily used are pounds per square inch-feet per minute. The term is normally considered to provide some measure of severity of service, and thus relates to a seal's life.

QUENCH: A neutral fluid which is introduced on the atmospheric side of the seal for the purpose of diluting fluid which may have leaked by the faces of the seal.

RADIAL MOVEMENT: Movement perpendicular to the shaft axis.

ROTARY (ROTARY RING): That portion of the rotary unit that contains the rotary face.

ROUGHNESS: Fine irregularities of the surface texture including those caused by the production process. The measurement involves the arithmetic average of the height of the irregularity expressed in micro inches.

RUN-IN: The period of initial operation during which the seal lip wear rate is greatest and the contact surface developed. Some leakage may occur during this time.

RUNOUT: Twice the distance which the center of a shaft is displaced from the axis of rotation; that is, twice the eccentricity.

RUNNING TORQUE: The torque which is required for sustaining rotary motion of a shaft operating under stabilized conditions.

SEAL CAVITY: The annular area between a stuffing box bore and a shaft into which a seal is installed.

SEAL CAVITY PRESSURE: The pressure on the upstream or high pressure side of the seal assembly.

SEALING FACE: The lapped surface of the seal which comes in closest proximity to the face of the opposing mating ring of a seal, thus forming the primary seal. With reference to lip seals, the preferred term is "seal contact surface."

SEALING FACE WIDTH: The radial distance from the inside edge to the outside edge of the sealing face.

SECONDARY SEAL: A device, such as a bellows, piston ring, or O-ring, which allows axial movement of the primary seal face of a mechanical seal, without leakage.

SHAFT ECCENTRICITY: The radial distance which the geometric center of a shaft is displaced from the axis of shaft rotation.

SHAFT OUT-OF-ROUND: The deviation of the shaft from a true circle.

SOLID LENGTH: See Minimum Compressed Length.

SOLID SEAL RING: A seal ring made of a single material, as opposed to one with a coating.

SPIRAL WOUND GASKET: A flat gasket which is formed by winding a metal and a suitable filler layer into a spiral. The layers, in a cross section parallel to the winding axis, are usually "V" shaped. See Static Seal.

SPRING PRESSURE: The face pressure between the primary elements of the seal, which results from the spring load.

SPRING RATE: The force required to extend or compress a spring, a unit distance.

STARTING TORQUE: The torque which is required to initiate rotary motion.

STATIONARY (STATIONARY RING): A ring which is mounted in, or on, the non rotating seal assembly. Normally, it is the primary sealing member which loads against the rotating mating ring.

STUFFING BOX: A cylindrical cavity and the enclosing stationary parts surrounding a shaft, designed to accept a packing or seal for the purpose of preventing leakage along the shaft.

TANDEM SEAL: A double seal arrangement consisting of two seals mounted one after the other, with the rotating faces of the seals oriented in the same axial direction.

THROAT BUSHING: A bushing mounted in the impeller end of a seal chamber to isolate the fluid surrounding the seal from the pumped fluid. Also called restriction bushing.

THROTTLE BUSHING: A bushing placed outside a seal to allow steam or other quench fluid to be passed by the seal for cooling or removal of leakage. It also prevents massive leakage in the event of failure of the primary seal.

TORQUE: As applied to sealing, a resistance to shaft rotation, caused by a seal's frictional drag. It is normally expressed in foot-pound, or in inch-pound units.

UNBALANCED SEAL: A seal arrangement in which the full hydraulic pressure of the seal chamber acts on the faces of the mechanical seal without any proportion of that force being reduced or counteracted through seal design.

UNIDIRECTIONAL SEAL: A seal which prevents the passage of fluid from one direction only.

VAPOR PRESSURE (VAPOR POINT): The pressure at a given temperature below which a liquid changes to a gas.

VENT CONNECTION: A connection in the gland plate outboard of the seal through which leakage may be vented. Also called drain.

WAVE SPRING: A washer type of spring which has been deformed to have a multiple wave pattern in a plane perpendicular to its axis. Since it utilizes little axial space, it is frequently used to produce compact seal assemblies.

WEDGE TYPE SEAL: A type of secondary seal, of wedge-shaped cross section, sometimes used in mechanical seals.

WEEPAGE: A minute amount of liquid leaked by a seal. It has rather arbitrary limits, but is commonly considered to be a leakage rate of less than one drop of liquid per minute.

WELDED METAL BELLOWS: A bellows fabricated by welding together a series of thin metal disks to form an accordion type structure which, when assembled to other components of a seal assembly, acts both as the secondary seal and as a loading device.

Damage Analysis and Troubleshooting

Common Causes of Premature Failure

- Coupling Misalignment
- Heat
- Cavitation
- Air Entrapment
- Overpumping
- Pipe Strain
- Bearing Failure
- Impeller Problems
- Poor Gasket Area
- Poor Condition of Equipment
- Improper Installation
- Loss of Environmental Controls

Coupling Misalignment

Improperly aligned couplings frequently cause seal and bearing failures. Vibration generated by misalignment causes chipped or broken faces, as well as overheated and damaged bearings.

Solution: Adjust the motor side only.

Alignment Methods:

- Dial Indicator Method
- Straight Edge
- Laser Equipment

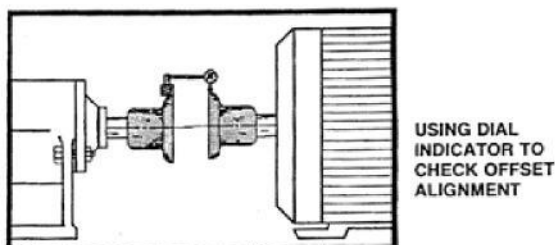
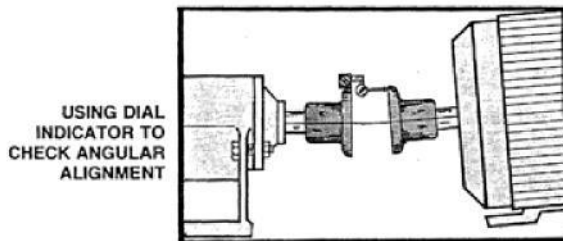

Figure 33 - Dial Indicator Method

Dial Indicator Method

Using a dial indicator (Figure 33) mounted on the pump coupling flange, indicate against the face of the motor flange and rotate to find angular misalignment. With use of shims under the motor, adjust until both flange halves or flanges are parallel.

Next, place the dial indicator against the O.D. of the opposing flange and rotate to find the offset. Using shims and, manipulating side to side, make adjustments to set "dead on."

Straight Edge Alignment

Find angular misalignment by using a taper gauge (Figure 34). Shim and adjust until flange ends are parallel.

Using a straight edge, bridge across both flanges to check level, then check at 90° each side of top. Adjust and shim until any offset is neutralized (Figure 39). After alignment is achieved, tighten the motor securely to its base and check again.

Laser Equipment

Laser equipment comes with very clear instructions about how to correct angular and offset misalignment.

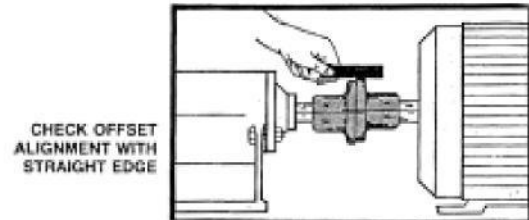
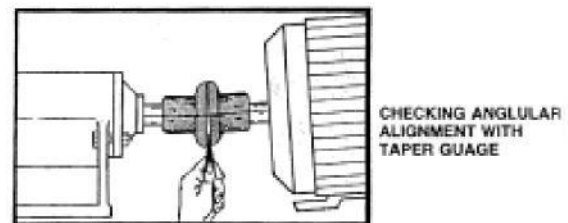

Figure 34

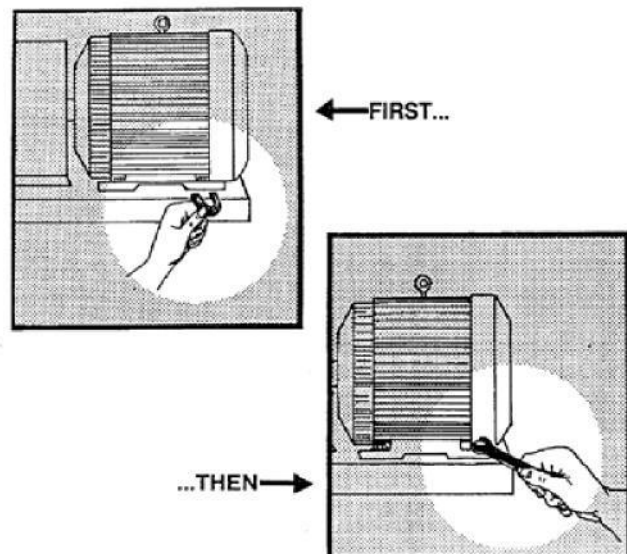

Figure 35 - Shim Motor to Achieve Alignment

Heat

All mechanical seals have temperature limits. Also, most applications have limits, above which negative results are realized (Figure 36).

- O-rings can overheat, compression set or cook.
- Different products may solidify, vaporize, crystallize or salt.
- Some products become more aggressive (corrosion).
- Seal faces can overheat causing heat-check, thermal shock, distortion and pitting.
- Metal parts grow, which hinders seal flexibility and faces can loosen from their carriers.

Heat, above system temperature, can be generated in various ways, which adversely affect seal performance:

Running a Mechanical Seal Dry

If your pump is allowed to run dry, without lubrication for the mechanical seal, it will generate excessive heat. This heat will cook the O-rings, and the seal faces can overheat and warp. All of this results in failure. Running dry for only a few seconds can destroy a mechanical seal.

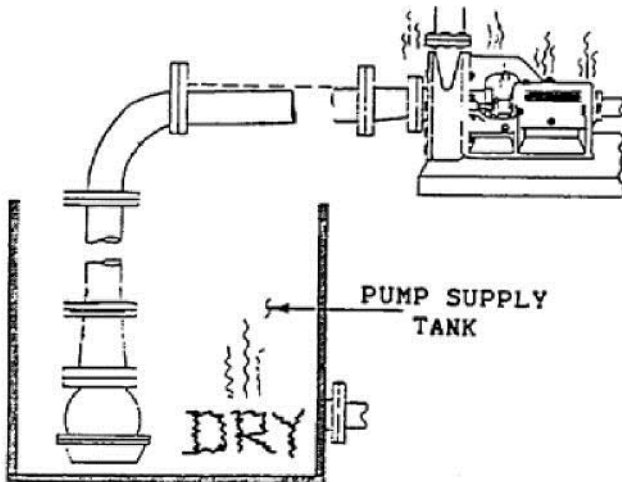

Figure 36 - Excessive Heat

Running a Single Seal With a Vacuum in the Seal Chamber

The results are much the same as running dry. A good way to overcome this problem is to run a recirculation line, which will keep the seal chamber flooded and pressurized around the seal and avoid heat build-up. A recirculation line will circulate heat out of the seal chamber.

Limited Flow Through the Seal Chamber Due to Front and Rear Wear Bushings/Rings

A recirculation line from the seal chamber to the suction inlet, which insures constant flow of product through the seal chamber and evacuates heat, can also correct this condition.

Limited Flow in Seal Chamber due to Expeller Vanes on Backside of the Impeller

This condition can be stopped by one of two ways:

- Remove expeller vanes
- Run a recirculation line from the stuffing box to the suction piping or a discharge return.

Poor Start-up Procedure

Air Pocket in Seal Chamber

This problem can be corrected in most cases by a recirculation line, however, bleeding the air from the seal chamber, before startup, is always a good procedure.

To stop this habit (air in the seal chamber), a procedure should be implemented to insure that all the air is bled from the pump and the suction is open completely. If this problem continues, a pressure switch may be installed on the discharge to prevent startup until flow is indicated.

Improper Operating Procedure causing Air Entrapment in the Seal Chamber

- Do not shut off the discharge before stopping the pump.
- Do not close the suction valve before stopping the pump.
- Do not pump suction supply dry.

Cavitation

Cavitation (Figure 37) is a condition created by insufficient available head at the suction side of a pump, to satisfy discharge demand. This causes gas bubbles in areas where pressure decreases abruptly. The bubbles collapse (implode) when they reach areas of higher pressure, causing hammering, vibration and damage to pump parts (impeller, volute and back plate). It sounds like pumping rocks. Causes:

- Low level in supply source (Figure 38)
- Suction line too small
- Build-up obstruction or some type of restriction of flow to suction/impeller

- Air entrapment because of poor piping design (Figure 43a)
- Discharge into supply tank designed improperly, causing air entrapment through turbulence.

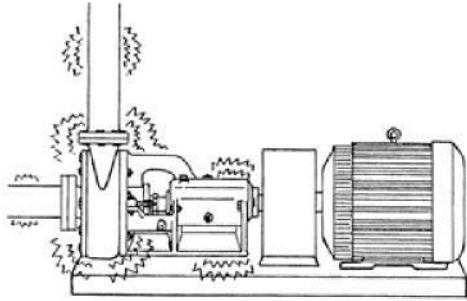

Figure 37

The vibration caused by cavitation is transmitted along the shaft to the seal, bearings, coupling and the motor. If allowed to continue, this vibration from collapsing bubbles will damage pump parts and cause seal and pump failure.

Do not continue to operate a system with cavitation conditions

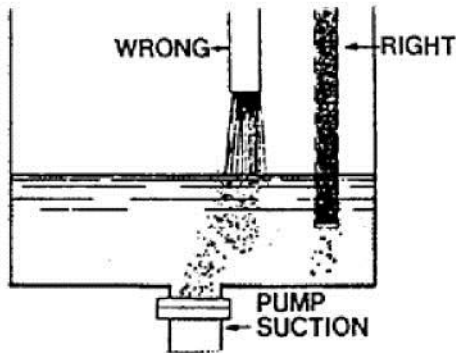

Figure 38

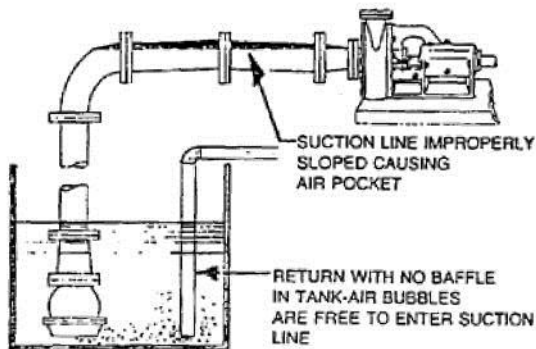

Figure 38a - WRONG

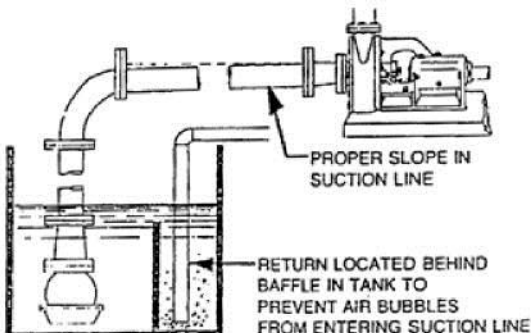

Figure 38b - RIGHT

Air Entrapment

When air gets trapped in the suction piping of the pump it can cause cavitation (as mentioned above). Often air entrapment/entrainment (Figures 38a & b) is caused by positioning the return to the supply tank in a poor location or above the fluid level. The return line to the tank should discharge below the fluid level and away from the tank outlet. If space is a problem, use a baffle to block air bubbles from flowing into the tank outlet.

Over-pumping

When a pump is used to pump beyond its design or recommended limits, the result is often overheated bearings, cavitation, motor and seal failure. Do not over pump (Figure 39). Consult pump curves provided by the pump manufacturer.

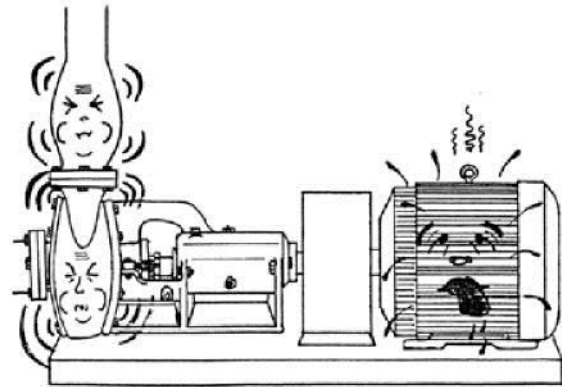

Figure 39

Pipe Strain

When piping at the pump is not properly aligned with the pump flanges (suction and/or discharge), pipe strain results (Figure 40a). Causes include:

- Improper Support
- Thermal Growth
- Poor Installation
- Settling of Old System
- Lack of Flex Couplings

Effect:

- Coupling vibration caused by pipe deflection/misalignment
- Bearings overheat because of side loading
- Impeller binds in casing
- Premature failure of bearings, coupling, motor and seal

Solution:

Pipe strain can be prevented with proper support (hangers), vibration suppressing/flexible connectors (expansion joints) and proper piping alignment (Figure 40b).

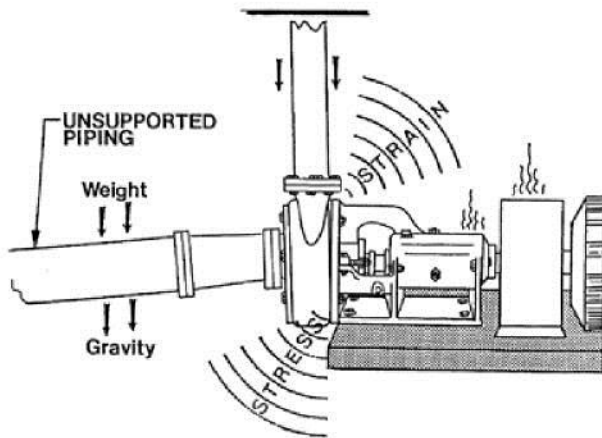

Figure 40a - WRONG

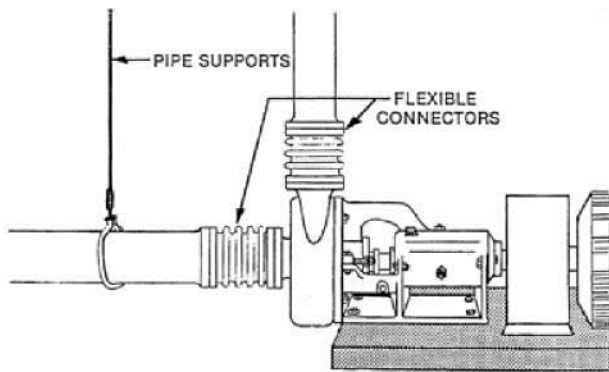

Figure 40b - RIGHT

Bearing Failure

Bearing failure causes instant problems. When a bearing fails, it loses its ability to support the rotating shaft. The rotating element will whip erratically, causing rotating parts to strike stationary parts. It matters little about the quality of the seal being used, it will fail immediately.

Impeller Problems

1. Adjust the impeller to the proper setting before securing the seal to the shaft.
2. Do not use impellers, which are not dynamically balanced.

Poor Gasket Area

A good gasket surface (125 to 200 RMS), perpendicular (90°) to the shaft, is necessary. Care must be taken to correct any gasket surface area that is rough, pitted, marred or has an eroded surface and/or is not 90° to the shaft/sleeve.

If the gasket area is damaged and/or not square, a facing tool or a lathe will recondition it to the desired condition.

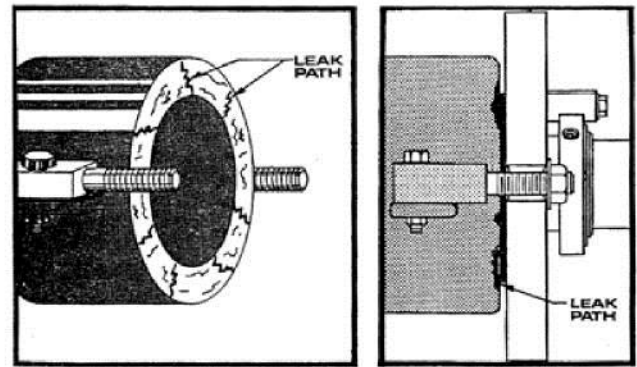

AS-Cast Stuffing Box Face

Seal Installed on rough stuffing box face

(Figure 41)

Poor Condition of Equipment

1. Check shaft/sleeve, it should be seal size +0.000" to -0.002" (0mm to 0.05mm) (Figure 42).
2. Check total indicated run out, it should not be more than 0.003" (0.08mm) (Figure 43).
3. Check end play (thrust) - maximum of 0.005" (0.13mm) (Figure 44).
4. Check all keyways, threads, and shoulders for sharp edges, which could damage elastomers. Round edges or tape over before installation (Figure 42).

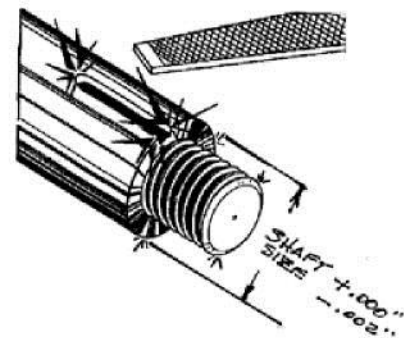

Figure 42

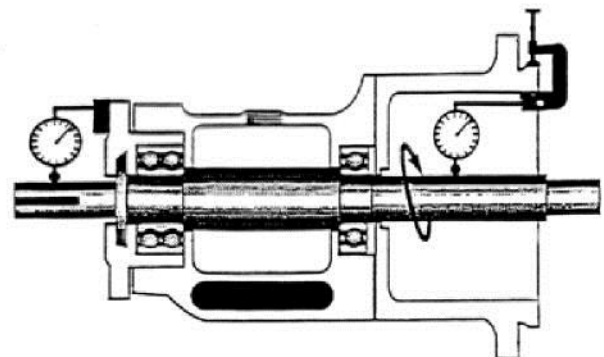

Figure 43 - Using dial indicators to check shaft runout

5. Check for shaft concentricity to the housing/seal chamber, which should be within 0.005" (0.13mm) maximum (Figures 45 & 46).

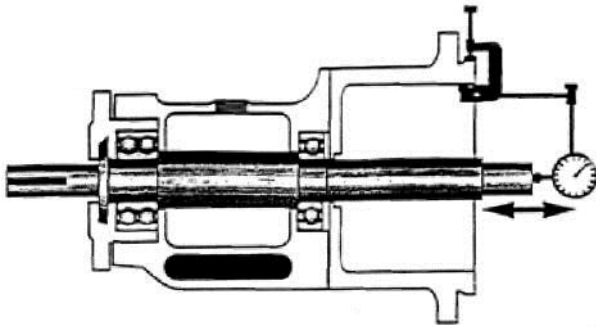

Figure 44 - Checking for shaft end-play

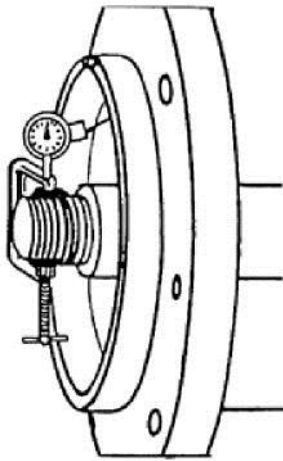

Figure 45

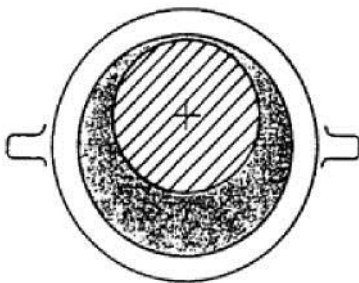
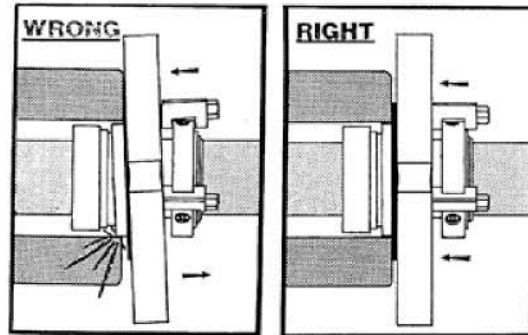

Figure 46 - End view showing non-concentric ox and shaft

Improper Installation

1. Faces dirty or damaged
2. Secondary seal (elastomer) damaged
3. Seal set at wrong working length
4. Improper environmental controls
5. Seal improperly aligned (Figure 47)
6. Wrong seal for application



Pilot is bent when seal is not installed properly

Properly installed seal

Figure 47

Flash Control

When a product reaches the pressure and temperature, which causes it to vaporize, it is said to be at its flash point. Normally the lower the specific gravity of a liquid, the more sensitive or prone it is to flash.

When a product flashes between seal faces it will blow the faces apart, which causes chipped edges on the O.D. and less often on the I.D., when they slam back together. Flashing also causes scuffed and/or deep wear on the faces. Combined, these conditions will cause premature seal failure. Solution:

1. Try a quench and drain on the atmospheric side of the seal to control temperature at the faces.
2. Use a double seal with a cool compatible barrier fluid to lower the temperature at the seal faces.
3. Flush with a cooler product.
4. Use discharge return to raise the seal chamber pressure.

Loss of Environmental Controls

Environmental controls are used to create a better environment for the sealing device, in a given application, pump design and seal. Seal life is often directly dependent on effective application of environmental controls.

Troubleshooting

With few exceptions, when a seal fails in the line of duty, one can normally find the root cause by looking at the damage (fingerprints) left on the seal components. Certain conditions create unmistakable marks and/or patterns on the seal parts and by inspecting the damage and knowing the causes, adjustments can often be made to prevent re-occurrence.

NOTE: When looking at seal face combinations, it is useful to know that the wider of the two faces is normally the hardest face and the narrow face is the softer or the wearing/sacrificial face (the face which wears away as a normal function).

Symptoms of Hard (Wide) Face Damage

Wear Track

- A normal wear track on a face, which has been installed properly, will be a uniform concentric path that is the same width as the opposing face. The wear pattern should be completely even around the track, with no lighter or darker areas.
- If the wear track is not concentric with the OD and ID of the face, it indicates that the track ran off the edge, the seat was not centered, the seal was cocked when installed, or the shaft is not centered in the seal chamber.
- A wide wear track (wider than the opposing face cross-section) indicates eccentric movement of the shaft. This condition can be caused by bad bearings, impeller not balanced or a bent shaft.

Cracking or Chipping

- If a hard face is cracked or chipped it is likely that it was mishandled, caused by vibration, thermal-shock (in the case of ceramic) or hammering effects of cavitation. Poor coupling alignment, seal cocked or bad bearings could cause vibration.
- Abrasives embedded into the softer face, and exposed to the opposing face, normally cause a deep wear track on the hard face. Another possible cause is a cracked opposing face, which shears away at the hard face (Tungsten Carbide vs. Silicon Carbide).

Symptoms of Soft (Narrow) Face Damage

Chipping, Coking, Abrading

- Flashing, vibration or mishandling causes chipped edges on the OD of the sacrificial face. Cool seal or raise pressure.
- If the face shows signs that look like a phonographic surface, migrating abrasives are the cause. This creates a leak path. Upgrade to hard faces.
- If a face shows signs of coking, the solvents have been cooked out of the oils being pumped. It

looks like carbon residue and varnish sticking on the I.D. and O.D. of the face. Cool the seal.

- Cracked sacrificial faces are usually caused by vibration or mishandling.

Chemical Attack

- A carbon can show various stages of chemical attack, from mild etching to pitting to a dissolved state.
 - Merely lowering the temperature of the aggressive oxidizing product may solve etching.
 - Pitting or blistering typically is caused by one of two reasons: either the carbon is a type other than chemical grade (low grade), or the carbon is absorbing the oxidizing product which, with heat, expands and causes damage.
 - Dissolved carbon shows a complete lack of compatibility and a different grade or material should be used.

Excessive Wear

- When the sacrificial face has its protruding nose worn away, we call this excessive wear. If the seal shows excessive wear after years of service it has merely done its job and is now spent. However, if excessive wear takes place after only a short time, normally it can be traced to one of six problems.
 - A cracked opposing hard face will act as a shearing device and make quick work of a sacrificial face.
 - Too much pressure in the seal chamber will hydraulically load the seal beyond its designed abilities. Use a balanced seal.
 - If the seal is installed at the wrong operating length, with the spring(s) over compressed, the face will be sacrificed quickly.
 - Chemical attack, as mentioned, can dissolve the dynamic surface because of elevated temperature and reduce the length of the sacrificial nose promptly.
 - Abrasive service can quickly erode a carbon face. Upgrade to hard face or use a double seal.
 - Dry running can make short work of a carbon face if the pressure and velocity combined exceeds the limits of the face material.

Sticking Faces

- Faces stick together and seal fails at start up. Some products, such as sugar, will stick faces together and at startup can break large pieces from the sacrificial face. Typically drive pins are also damaged in the

process. Use heated quench or heated double seal with barrier pressure 15 psi greater than seal chamber pressure.

Blistering

- Blistering of the dynamic surface of the seal face. Some grades of carbon blister, when asked to perform in demanding applications. Blisters appear to be small craters in the carbon face. Poor grade, less dense or porous grades of carbon may contain small pockets of gas within their structure. When subjected to heat, generated by the two seal faces rubbing together, the gases contained within these voids expand and cause tiny explosions, which create the small craters. Upgrade to a better carbon.

Face Wear in One Spot Only

- Wear in one spot is created by one of three examples.
 - If the seal is dramatically cocked during installation it can wear in one spot.
 - Air in the seal chamber can cause wear in one spot. Because of reduced lubrication between the faces at the top portion of the seal, more friction/wear results.
 - Face not flat (within 2 to 3 light bands)

Heat Checking

- Heat checking appears as small fractures in the surface of a seal face which extend completely or partially across the face from the I.D. to the O.D. These tiny fractures will quickly damage an opposing face as they act like several shearing blades. Reduce heat and/or change to silicon carbide.
- Heat checking happens more frequently with coated surfaces. Heat, which is generated by the seal, causes expansion. The less dense or softer substrate will expand faster and more dramatically than the hard coating, causing a split up effect between the soft and dense layers. This splitting causes fractures in the coating and is called heat checking. Do not use coated seal faces if temperature can not be controlled.
- Running dry also can cause heat check. Use a double seal to insure cooling and lubrication is always present if dry running is likely.

What do the O-rings tell you?

- Incompatibility will cause swelling of elastomeric material. If the cross section of an O-ring is larger than normal, it can be traced to chemical attack. Always be sure you know what product is being pumped, including trace amounts of stray chemical, which may be present. Change to a more suitable compound.

- Extruded O-rings are caused when pressure, sometimes combined with temperature, forces the O-ring to deform and creep into the open areas between parts of the seal. Extrusion can cause the seal to become inflexible and could result in a cut elastomer, and create a leak path. The two most popular methods to cure extrusion problems are:

- Use an O-ring with a higher durometer (example: from 70 duro to 90 duro) which will resist extrusion.
- Seal designs often incorporate anti-extrusion or back-up rings, which have a hard durometer and block the extrusion avenue.

- Compression set is a condition created by the combination of heat and compression, which actually reforms the O-ring into the shape of its containment. When the elastomer is removed it retains the new shape.

To control compression set, you must keep the seal cooler. Use quench and drain, double seal with cool barrier or in some cases a simple re-circulation line, to suction, will reduce pressure and evacuate the undesired heat.

- Nicked or cut O-rings are caused, almost with no exception, by handling. Take special care to protect O-rings during installation. All sleeve/shaft shoulders should be free of sharp corners and be sure to tape over keyways and threads, which could damage O-rings during installation.
- O-rings that have lost their elastomeric qualities and are hard, cracked or brittle have experienced heat, chemical, and/or ozone attack.

- All O-rings have temperature limits. If the system is too hot, cool it or change to an elastomer with more favorable temperature limits.
- Chemical attack will cause O-rings to swell, but as the solvents are rendered out of the compound (degassing) they can shrink under size and become brittle. Be sure and use the correct O-ring compound for the product being processed.
- Ozone is a strong smelling form of oxygen created by electrical discharge in air and causes similar symptoms as overheating. Some elastomers become brittle and crack. Even shelf life is an issue. The most commonly known elastomer in the mechanical seal world, which is adversely effected by ozone, is nitrile.

Hardware Damage

Always check metal parts for surface damage, from a chemical compatibility standpoint. If pitting, etching or corrosion is present, a different alloy may be indicated.

- Check the sleeve for wear tracks, which indicate contact between rotating and stationary parts. Typically this is caused by poor installation (cocked when installed), excessive shaft movement, the shaft is not in the center of the seal chamber or the shaft is bent. The wear track on the hard face can help direct you to the true cause.
- Scoring on the sleeve O.D. If the scoring is located under the seat, excessive shaft movement or product build-up on the atmospheric side of the seal are suspected.

If scoring is not concentric we suspect misalignment. Other damage to the sleeve could include fretting by the dynamic O-ring, which is normal for some designs. Coat the area, where the wear is normal, with a hard coating.

- Scoring on the I.D. of the sleeve can only happen when the seal is not properly secured to the shaft before start-up.
- If the sleeve of a cartridge seal has set screw marks on the O.D., it suggests that the setscrews were not aligned with the holes through the seal sleeve. The set screws must pass through the sleeve to properly drive the seal.
- If the set screws of a cartridge seal drive collar are set against the seal sleeve it causes any or all of the following:
 - Shaft will spin inside the seal sleeve and destroy the seal shaft O-ring.
 - Seal springs will not hold proper working length.
 - Sleeve can be distorted, out of round.
 - The drive collar will push forward against the gland face, causing metal to metal wear.
 - The set screw marks are unmistakable.

Face Carrier and the Dynamic O-ring

Based on the designs of the pusher (spring) seals, the dynamic O-ring(s) is placed at different locations. Some dynamic O-rings are placed against the pump sleeve/shaft, some against the drive collar and others against the I.D. or O.D. of the face carrier.

- Dynamic O-rings all make a wear mark called a fret. The condition of the fret tells much about the conditions under which the seal has been operating.
 - Pitted - chemical attack
 - Deep Wear - abrasive service
 - Wide (more than 0.062" (1.6mm)) - axial movement
 - No Fret - very short seal life or well lubricated

Drive Pin Damage

The drive pins in a rotary seal (springs rotate with the pump shaft) ensure that the face rotates with no slip at startup and maintain constant contact with the carrier and/or drive collar as the seal runs. Conversely, drive pins in a stationary seal (springs do not rotate with the shaft) act as anti-rotation pins and keep the face and carrier from rotating. In both designs the pins are subject to stresses and wear as they are in constant contact, metal-to-metal, and rubbing as the pump starts, stops, vibrates, and generates its range of movement. Pins that have been in service will show their scars by:

- Unusually long wear areas suggest axial movement.
- Bent pins suggest faces sticking (slip stick).
- Deep wear is an indication of vibration and/or abrasive service.
- Corroded pins show chemical attack and a material upgrade is needed. (Example: 316SS to Hastelloy C)

Broken Springs

Springs break in various ways:

- Fatigue from excessive shaft movement.
- Heat plus stress plus chlorides equal chloride stress corrosion and is often a problem with stainless steel springs.
- Mishandling is another cause of broken springs. If the drive pins are not in their slots and someone rotates the carrier by hand, it can shear the springs.

Gland Damage

Damage to the gland provides important clues:

- Large dents in the gland anywhere suggest rough handling.
- With cartridge seals, drive collar contact with the gland suggests the set screws were not secured properly or the centering clips were removed prior to tightening the set screws. Some indications about how well the seal was centered can be seen on the gasket area.
- Flat washers should always be used. If nut gouges are on the gland, washers were not used (Often the binding corners of the flats on bolts or nuts can pull a gland off center).
- Check for rubbing of the sleeve on the minor I.D. of the gland. This will indicate excessive run-out, misalignment, poor centering or bent shaft. This will often show discoloration from heat, where metal parts have been rubbing.

Guidelines for Calculating Return on Investment from Packed Pumps to Sealed Pumps

	PACKING	MECHANICAL SEAL
A. PACKING		
1. Cost of packing per packing change.		
2. Number of packing changes annually		
3. Annual packing cost:		
Total of #1 x #2		
B. BEARINGS		
4. Cost of bearing		
5. Number of bearing changes/year		
6. Annual bearing cost		
Total of #4 x #5		
C. SLEEVES		
7. Cost of sleeve		
8. Number of sleeves changes/year		
9. Annual sleeve cost		
Total of #6 x #7		
D. LABOR		
10. Labor Cost		
11. Average time required to pack properly		
12. Labor cost per packing change		
Total of #10 x #11		
13. Annual labor cost		
Total of #2 x #12		
E. WATER		
14. Amount of water used to flush S.B. expressed in GPM		
15. Amount of water used annually		
16. Cost of water / 1,000 gallon		
17. Annual cost of water		
Total of #15 x #16		
F. ENERGY		
*18. Operating x hours x power req. per hour x cost per KW - annual cost 8,000 x .2 x .03		
G. Add lines 3, 6, 9, 13, 17 and 18		

*Packing required approximately 2kw/hr. Mechanical seals require approximately .33 kw/hr

Customer Contact Info

Company _____

Mailing Address _____

City _____ State/Province _____ Zip/Postal Code _____

Contact Name _____

Phone _____ Fax _____ Email _____

Current Seal

Equipment

- Centrifugal Pump
- Positive Displacement Pump
- Progressive Cavity Pump
- Mixer/Agitator
- Other

Survey Tag No _____

Current Seal Mfr _____

Model No _____

Location _____

Dimensional Data

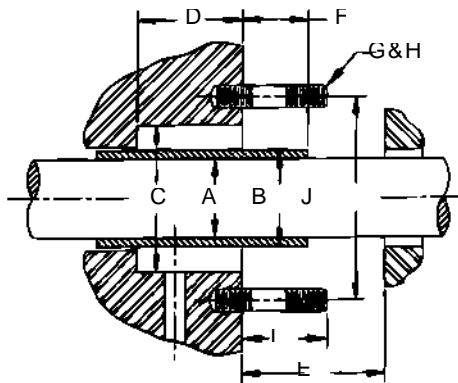

A. Shaft Diameter

Hardened: Yes No

F. Sleeve Extension _____

B. Sleeve Diameter _____

G . B o l t D i a m e t e r

C. Bore Diameter _____

H . B o l t Q u a n t i t y

D. Bore Depth _____

I . B o l t E x t e n s i o n _____

E. First Obstruction _____

J . B o l t C i r c l e _____ Bolt Circle

Bolt Orientation _____ Max. Gland Diameter _____

Gland Shape Round Elliptical Flush Port _____ Size _____

Does the shaft step down below the sleeve extension? Yes No Diameter _____

Typical Seat Configuration:

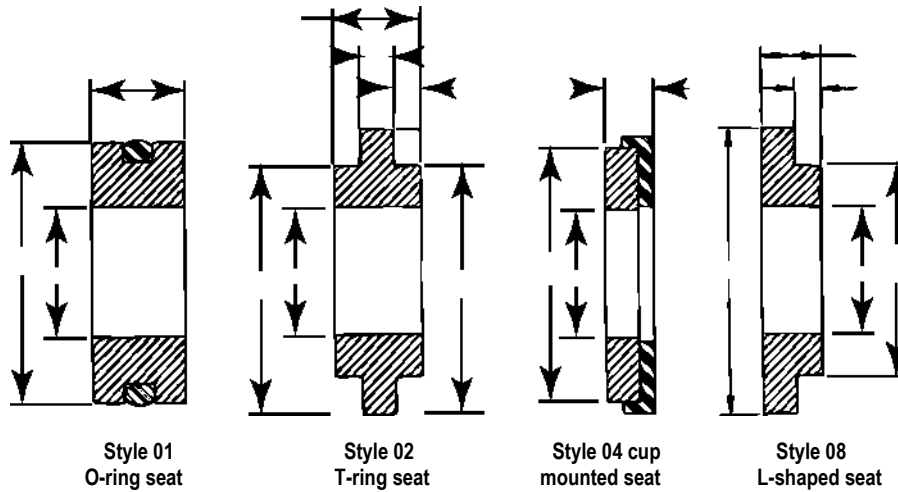

Application Data

- OEM
- Aftermarket

Annual Usage _____

Peak Month Usage _____

Date Required _____

Process Information

Process/Fluid _____ Max. Stuffing Box _____

Shaft Speed (RPM) _____ Process Type _____

Temperature (°F) _____ Corrosive Abrasive

Pressure (psig) _____ Viscosity _____

Suction _____ Movement of Shaft _____

Discharge _____ Axial _____ Max _____

Vessel _____ Radial _____ Max _____

Environmental Controls

Can the process be flushed? Yes No Media _____

Cooling available? Yes No Media _____

Barrier fluid available? Yes No Media _____

Present Sealing Device

Packing _____ Approximate Cost _____

Seal Style _____ Approximate Life _____

Manufacturer _____

Elastomer

- EPR Fluoroelastomer Perfluoroelastomer
 Other _____

Mixer Detail

- M . W i n d o w W i d t h
 N . W i n d o w H e i g h t
 O . D i s t a n c e t o C o u p l i n g

Size _____

Is stuffing box removable? Yes No

If yes, what is the

Box Length _____

Bolt Circle _____

Bolt Quantity _____

Box Size _____

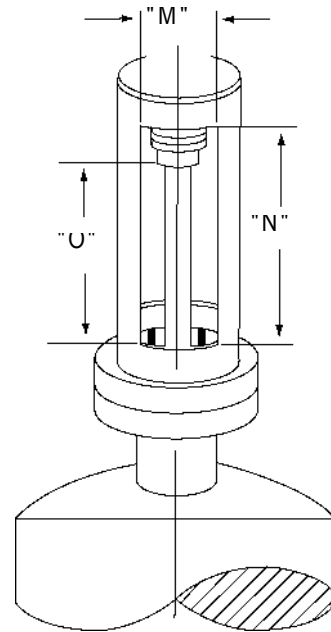

Gland Detail

1. Mark tap location(s)/ Flush or Barrier
2. Mark bolt locations and indicate if drilled or slotted

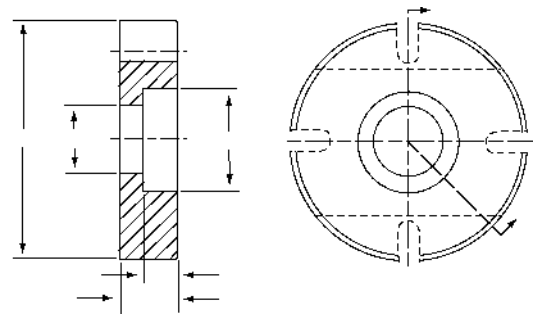

If round gland cannot be used, provide additional details

For new installations, Klozure® will need to know if your equipment is presently sealed, and the life of the current seal. In addition, the following information (as a minimum) is required:

Operating Conditions

Fluid Description:

Clean Dirty or Abrasive Slurry Toxic

Percent of solids _____ Micron size _____ Sp. Gravity _____

Suction pressure (psi) _____ Discharge pressure (psi) _____

Box pressure (psi) _____ Shaft speed (rpm) _____

Direction of rotation from driver end CW CCW

Auxiliary Availability

Cooling water available Yes No Temp (°F) _____ Pressure (psi) _____

External liquid flushing Yes No Temp (°F) _____ Pressure (psi) _____

Flushing liquid description

Seal Materials

Based on your experience with the fluid being sealed, please indicate acceptable materials from the list below:

Metal Parts

Brass Monel
 Mild Steel Carpenter 20
 Ni Resist Hastelloy Type
 Stainless Steel Type _____
 Other _____

Seats and Driving Rings

Buna-N (Hycar) Natural Rubber
 Neoprene Hypalon
 Viton Butyl
 EPR Rubber Silicone

Other _____

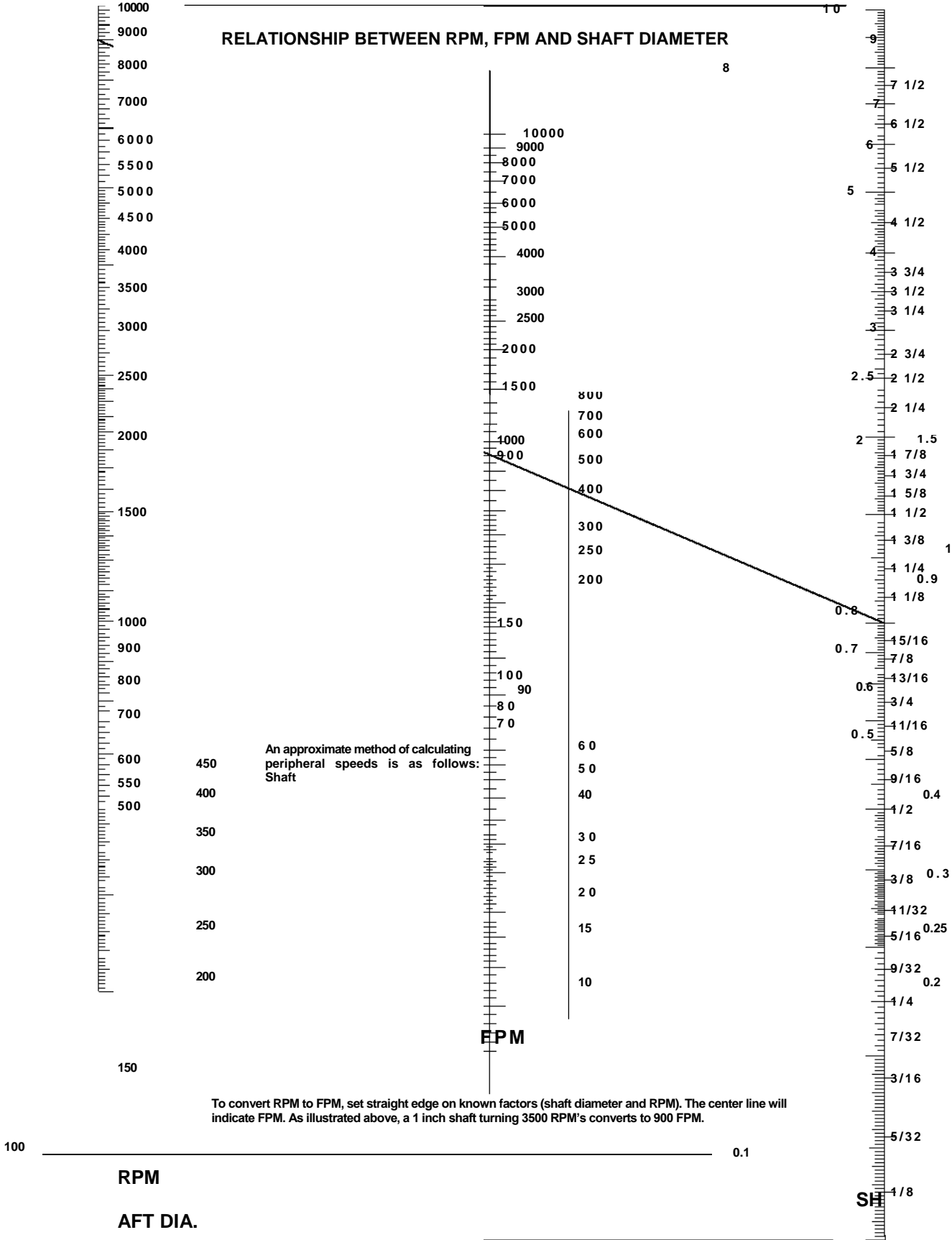

K L O Z U R E ® HIGH-PERFORMANCE DYNAMIC SEALS

AUTHORIZED

DISTRIBUTOR

WARNING:

Properties/applications shown throughout this brochure are typical. Your specific application should not be undertaken without independent study and evaluation for suitability. For specific application recommendations consult Garlock Klozure. Failure to select the proper sealing products could result in property damage and/or serious personal injury. Performance data published in this brochure has been developed from field testing, customer field reports and/or in-house testing.

While the utmost care has been used in compiling this brochure, we assume no responsibility for errors. Specifications subject to change without notice. This edition cancels all previous issues. Subject to change without notice.

GARLOCK is a registered trademark for packings, seals, gaskets, and other products of Garlock.

© Garlock 2010. All rights reserved worldwide.

**Garlock Klozure®**

A Division of Garlock Sealing Technologies
1666 Division Street
Palmyra, New York 14522 USA

Visit Klozure:

www.klozure.com

KLZ 2:92

VIA 3/10

Garlock
SEALING TECHNOLOGIES®
an EnPro Industries company

