

# Garlock Diaphragms

Materials and Technical Capabilities Brochure



# GYLON® PTFE Diaphragm

The best sealing and longest lasting

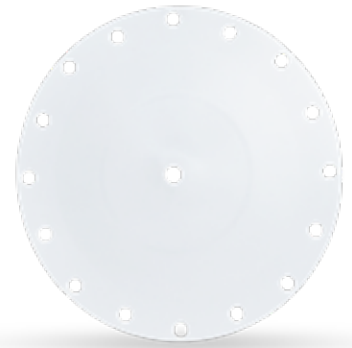

Exclusive to Garlock, the GYLON® PTFE Diaphragm material is a time proven product which is made using a proprietary process which optimizes quality and uniformity. Using the best available technology this material offers the longest cycle life in the industry and continues to outperform all competitive materials.

## MATERIAL PROPERTIES<sup>1</sup>

**Temperature<sup>2</sup>** Maximum +500°F (+260°C)

**CIP & SIP Capable** Maximum +300°F (+149°C)

**Meets Specification:** FDA Regulation 21CFR177.1550, 3A Sanitary Standard #20, ADC Free, NSF/ANSI 61, USP Class VI Chapter 87 & 88, USP Part 31, 281 and 661, TSE Free

## TYPICAL APPLICATIONS & MARKETS

- » Metering pumps
- » Diverting valves
- » Pressure sensors
- » Pressure regulators
- » Double diaphragm pumps
- » Industrial, CPI
- » Semi-conductor
- » Food & Dairy
- » Pharmaceutical
- » Bio-Processing

The high costs of losing or contaminating a process batch make it vital to use the best performing diaphragms available. Used alone, molded into shape or bonded to rubber, our GYLON® PTFE Diaphragm material will outlast competitive products and will keep your system up and running efficiently.

The two biggest advantages of a GYLON® PTFE diaphragm are the reduced void content and the increased flexibility. Void content and flexibility will affect all aspects of a diaphragm – leakage, cycle life, reliability, downtime, etc.

## INCREASED FLEXIBILITY

The ability to flex back and forth without deformation is one of the key features of a diaphragm. The greater the flexibility of a diaphragm, the longer it's life will be.

A longer diaphragm life means more uptime, improved equipment reliability, decreased labor and protection of downstream equipment.

The MIT Flex Endurance test simulates the bending forces a diaphragm sees in an actual application. Compared to Conventional and modified skived PTFE, GYLON® 3522 lasts about 3 times longer.

MIT Flex Endurance (ASTM D2176)  
Millions of Cycles

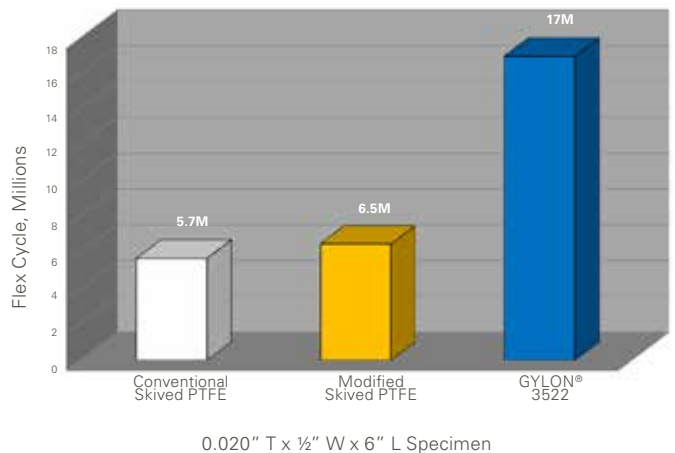

## REDUCED VOID CONTENT

Void content measures the potential for permeation through the material; the denser the polymer structure, the fewer voids there will be in the material. As void content decreases there will be less permeation which reduces the risk of cross-contamination and increases the life of the material. Lower void content also results in less deformation of the material.

The Stretch Void Index measures the % void content after the material has been flexed. Compared to both conventional grade and modified grade skived PTFE, GYLON® Diaphragm Style 3522 has a lower void content at <1%.

## CASE HISTORY

In a popular mechanically actuated pump, GYLON® PTFE Diaphragm lasted 8 times longer than the competitive modified skived PTFE.

	<b>GYLON® 3522</b>	<b>Modified Skived PTFE</b>
Lifetime:	4000+ Hours	500 Hours
Flex Cycles:	57+ Million	7 Million
Status:	Testing Suspended	Diaphragm Failed

GYLON® 3522 outlasted the planned test period and pumping was suspended because the diaphragm showed no signs of impending failure. Customer now uses GYLON® 3522 Diaphragms as their standard product.

ASTM D4895: Stretch Void Index (1/16" thk)

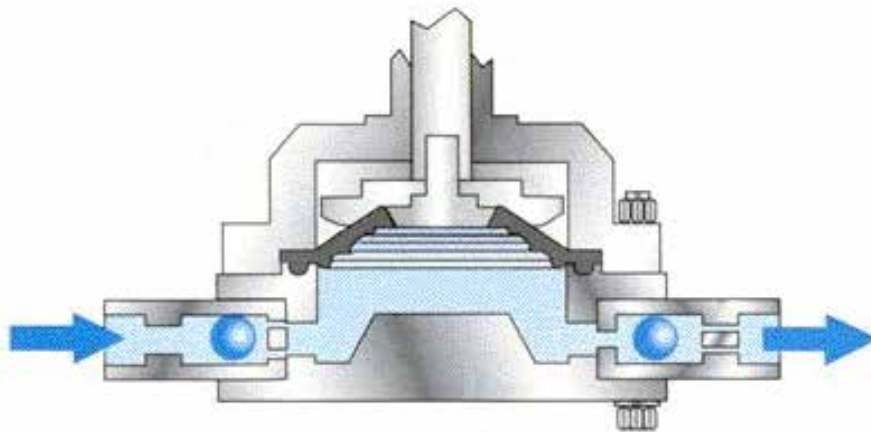
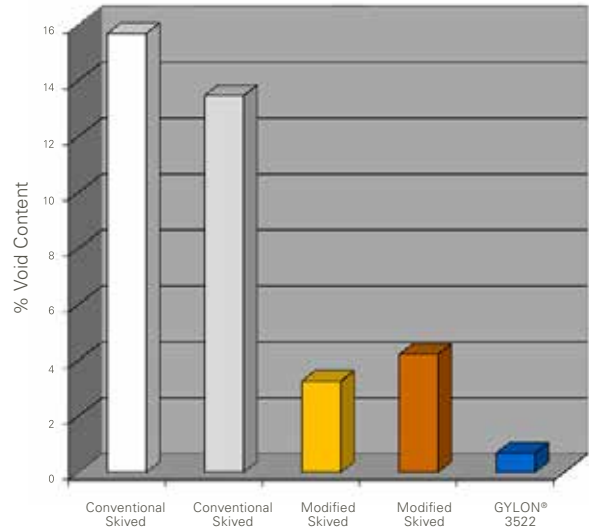

# GORE® PTFE Diaphragm

The toughest and most abrasion resistance



Exclusive to Garlock, the high performance, GORE® PTFE diaphragm material is a significant advancement over skived PTFE diaphragms. For Industrial Use only – this material is considerably stronger and offers greater flex life.

For those tough industrial applications where diaphragm failure is not an option, high performance GORE® PTFE sheet outperforms competitive skived diaphragms, particularly in abrasive applications. Our GORE® PTFE material is the strongest PTFE diaphragm material on the market and typically lasts 3-4 times longer in tough, abrasive applications.

## MATERIAL PROPERTIES<sup>1</sup>

<b>Temperature<sup>2</sup></b>	Maximum	+500°F (+260°C)
<b>CIP &amp; SIP Capable</b>	Maximum	+300°F (+149°C)
<b>Meets Specification:</b>	FOR INDUSTRIAL USE ONLY. Not for use in food, drug, cosmetic or medical device manufacturing, processing, or packaging operations.	

## TYPICAL APPLICATIONS & MARKETS

- » Metering pumps
- » Diverting valves
- » Pressure sensors
- » Pressure regulators
- » Double diaphragm pumps
- » Industrial, CPI
- » Semi-conductor
- » Solar
- » Mining
- » Paint & Coating

## STRENGTH

If you need the strongest, most abrasion resistant PTFE use our high performance GORE® PTFE diaphragms. Impact Strength, Tensile Strength, Mullens Burst and Tensile Creep are all indicators of how strong a material is.

Our GORE® PTFE diaphragms will stand up to high pressures, abrasives and will last an average of 3-4 times longer. High strength also indicates low deformation of the diaphragm – even at high pressures our material will maintain its engineered shape and keep your equipment running.

Our GORE® PTFE sheet can be used alone, bonded to rubber or molded into shape and is your best option for abrasive or high pressure industrial applications.

Property	ASTM Method	Sample Dimensions (Thickness)	Conventional PTFE (Literature)	GORE® PTFE (Test Data)
Impact Strength (ft lbs/in)	ASTM D-256	0.220 in.	2 - 3.5	30.4
Tensile Strength (psi)	ASTM D-638	0.220 in.	4000 - 5200	14920
Mullen Burst (psi)	ASTM D-3786	0.020 in.	180*	540
Tensile Creep (1000 hr, 1000 psi)	ASTM D-2990	0.100 in.	20% - 30%*	9% - 10%

Sample dimensions are given to compare conventional PTFE to Garlock's PTFE for testing purposes and do not represent actual diaphragm dimensions.

\*Actual test results for conventional PTFE film.

# Garlock® Rubber Diaphragms

Designed to meet your specifications

We offer a variety of high performance rubber compounds and also have the ability to design compounds to meet customer specific requirements.

With a world class bonding and molding operation, Garlock provides the best solutions to solve your specific needs.



## FDA COMPLIANCE

Offering a variety of rubber compounds to meet your needs, we can comply with the strictest standards. We have compounds that comply with FDA standard 21CFR 177.2600 and NSF 61.

## COMPOUNDING

We provide custom mixing with state-of-the-art equipment and all materials are manufactured to comply with customer specific chemical and physical characteristics.

## MOLDING

Garlock specializes in precision molded products that encompass a high standard of quality. We can produce your product to meet commercial or precision RMA standards. With over 50 presses available platen size is never an issue.

## RUBBER BONDING

Garlock is recognized as the industrial leader, providing a superior bond with a wide array of elastomers to multiple materials:

- » Rubber to fabric
- » Rubber to metal
- » Rubber to plastic
- » Rubber to PTFE

## PERFORMANCE

Diaphragms are often the most critical part in a pump or valve and there's no need to compromise on performance. Garlock provides custom designs and the longest lasting rubber compounds to outperform all competitive products.

## MATERIALS

- » Nitrile
- » Urethane
- » EPDM
- » Natural Rubber
- » Nylon
- » Fluoroelastomer (FKM)
- » Aflas
- » Styrene Butadiene (SBR)
- » Butyl
- » Hydrogenated Nitrile (HNBR)
- » Silicone



# Garlock® PTFE Rubber Composite

Designed to meet your specifications

With the two best PTFE Diaphragms available and some of the most respected rubber compounding capabilities, Garlock has a distinct advantage when it comes to product performance.



## PTFE SELECTION

With the widest range of PTFE options available, Garlock has a product to suit your equipment requirements.

- » GYLON® PTFE Diaphragm material is recommended for applications requiring the best cycle life, the best sealing ability or any equipment going into the sanitary market.
- » High performance PTFE GORE® material is recommended for abrasive or higher pressure industrial applications.
- » Both Conventional and Modified Skived PTFE are available upon request for those less demanding applications.

## BONDING

Our unique thermal and mechanical bonding process ensures the integrity of your diaphragm.

## CASE HISTORY

In a popular 2" Air Operated Double Diaphragm pump, the below diaphragms were tested for life cycle endurance. The one piece GYLON® with Rubber and Fabric composite lasted almost 4 times longer than the Modified Skived PTFE 2 piece diaphragms.

Diaphragms Tested:

- » GYLON® PTFE Diaphragm material bonded to a fabric reinforced rubber
- » 2 piece diaphragm with conventional PTFE and rubber
- » 2 piece diaphragm with Modified Skived PTFE and rubber

Operating Parameters:

- » 4,320 cycles per hour
- » Pumping water
- » Ambient temperature
- » 70psi pressure

## RUBBER MATERIALS

Offering a variety of high performance rubber compounds for both industrial and sanitary markets, we can also create custom rubber compounds to meet your specific requirements.

## OPTIONS

Fabric layers and metal inserts can also be included for added strength or installation efficiencies.



Cycle Life Test with AODD Pump

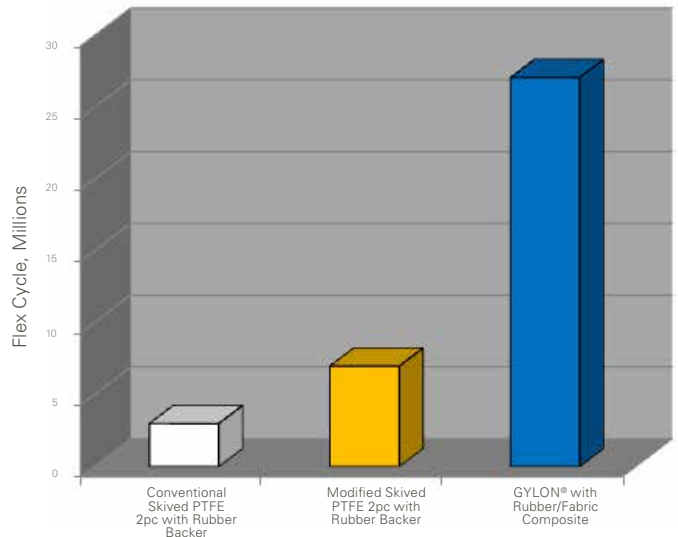

# Technical Capabilities

## Engineering support and performance testing

Garlock is recognized as an industrial leader, providing a wide range of molding equipment and a world class testing facility.

### CHEMICAL & MATERIAL LAB

Specializing in the characterization and analysis of fibers, fillers and polymers for non-metallic gasket and sealing materials. Included in the footprint of this lab is a 500 square foot "wet lab" which not only serves as a platform for traditional general chemical analysis but also as a sample preparation area for samples destined to be analyzed by more sophisticated thermal and optical analysis techniques.

### COMPOUND LAB

Focused on micro-scale rubber production this 1,200 square foot lab is used to produce small batches of experimental or custom made compounds and to study the results of small changes in formulation or processing.

### PHYSICAL LAB

The physical lab specializes in testing physical properties of raw materials and polymeric composites. The Physical Test Lab has the ability to test material in many different environments and liquid media.

### FUNCTIONAL LAB

Designed to conduct performance characterization tests for both static and dynamic sealing products. Sealing products can be evaluated under normal or accelerated operating conditions utilizing standardized or customer specific procedures.

### ENGINEERING

With world renown Product and Applications Engineers spanning multiple disciplines, we can provide the support you need. New product development, material design and in house testing are all available.

Our engineers are knowledgeable in real world applications and are working with global committees to create the standards governing process equipment.



# A culture of safety

Garlock is acknowledged as the global leader in high-performance fluid sealing products, committed to a culture of safety - making the world safer, sustainable and more reliable.

Our commitment to safety stems from our workplace culture and dedication to sealing integrity. We embrace safety not only for our employees, but for all of our customers as well. Our sealing products and solutions are tested to meet or exceed industry and regulatory agency standards. And that's a standard that defines who we are, and what Garlock stands for.



GORE is a registered trademark of W.L. Gore & Associates

<sup>1</sup> WARNING:

Properties/applications shown throughout this brochure are typical. Your specific application should not be undertaken without independent study and evaluation for suitability. For specific application recommendations consult Garlock. Failure to select the proper sealing products could result in property damage and/or serious personal injury.

Performance data published in this brochure has been developed from field testing, customer field reports and/or in-house testing.

While the utmost care has been used in compiling this brochure, we assume no responsibility for errors. Specifications subject to change without notice. This edition cancels all previous issues. Subject to change without notice.

GARLOCK is a registered trademark for packings, seals, gaskets, and other products of Garlock.

© Garlock Family of Companies 2014. All rights reserved worldwide.

<sup>2</sup> Due to the unique dynamics of actuated equipment, Garlock can not specify temperature limits for actual diaphragms. In diaphragm pumps and valves, there are variables such as but not limited to; diaphragm geometry, displacement, and pump speed that greatly affect the diaphragm performance. Experienced equipment manufacturers have confirmed that pumps and valves used in low and/or elevated service temperatures (40°F to 200°F) should be re-rated with respect to speed and pressure.

DIA 6:4 | 04.2024