

# Garlock Compression Packing

Long term leakage control



# Garlock Compression Packing

Compression Packing Products were once used to seal visible leakage in valves and control leakage in pumps. Through advancements in materials, design and technology, Garlock is now able to seal the most difficult fugitive emissions and eliminate pump leakage entirely.

Garlock compression packing products will contribute to maintaining a safe process, meet stringent fugitive emission limits and save resources, with proven reliability. Our product will generate the greatest return on initial investment in terms of leakage control, service life, dependability and cost effectiveness. We also provide expertise with highly knowledgeable application engineering support. The Garlock Compression Packing facility is committed to supplying the highest quality engineered products to industry throughout the world.

The facility also houses the Garlock Textile Division, where we continue to research and develop new fiber blends to bring customers a wide array of packings with optimum performance characteristics.

## CONTENTS

### PACKING PRODUCTS

#### Graphite Packings

Style 1300-E .....	3
Style 1306.....	3
Style 1333-G.....	3

#### Expanded PTFE and Graphite Fiber

Style 5100 GFO® Packing.....	4
Style G-200.....	4

#### Valve Packings: Fugitive Emissions Control Products

Style 1303-FEP .....	6
Style 212-ULE.....	7
9000-EVSP LE.....	8
9001-QUICKSET® LE .....	9
Style 1998 EZ BUSHING .....	9

#### Valve Packing: Power Generation, Steam

9001-QUICKSET® DT.....	10
9000-EVSP.....	10
Style 1298 & 1200PBI .....	11
Style 5882.....	12

#### Valve Packing Accessories

High Purity Carbon Bushings.....	13
Live Loading Hardware.....	13

#### Nuclear Applications

Style G-700.....	14
GRAPH-LOCK® N Style 1398.....	14

#### Water Conservation Products

HYDRA-JUST™.....	15
8093 DSA .....	16
FLUSH-GARD® Seal.....	16

#### Carbon Packings

Style 98.....	17
Style 5000.....	17
CARBAE™ 105 .....	18
CARBAE™ 108 .....	18

#### Soot Blower Sets

TORNADO PACK™ F1,F3, F5.....	18
GRAPH-LOCK® Sets.....	18

#### General Service Packings

SYNTHEPAK® Packings .....	19
Style 1925.....	19
Style 1965/1965-K .....	19

#### PTFE Packings

Style 5888.....	20
Style 5889.....	20
Style 5904.....	20

#### Specialty Synthetic Fiber Packings

Style 5200.....	21
Style 1850.....	21
Style 1947.....	21

#### Mild Service Packing

PACKMASTER® 1, 2, 3, 5 .....	22
PACKMASTER® 6, 7, 8 .....	23

#### Flush Water Products

Style 1004 Lantern Ring Coil .....	24
Crown Bush.....	24

### PACKING TOOLS

Flexible Extractor F00, F1, F2, F3, Packing Tools Set "B", Replacement Tips.....	25
Solid Shaft Extractors, Guillotine Packing Cutter .....	26
Lubricating Compounds.....	27

### ENGINEERING GUIDELINES

#### Style Selection

Style Index.....	28
Packing Materials .....	32
Construction .....	34
Material Selection.....	35

#### Effective Sealing

Equipment Condition.....	36
Installation Instructions.....	37
Testing.....	39
Gasket Spacers.....	40
Gland Load.....	40

### APPENDIX

pH Values.....	41
Common Oxidizers .....	41
Bolt Torque Table for Die-Formed Sets.....	42
Ordering Information .....	43
RPM /FPM Conversion Table.....	43
Application Data Sheet .....	44

CARBAE™, FLUSH-GARD™, HYDRA-JUST™ and TORNADO PACK™ are trademarks of Garlock

GARFITE®, GRAPH-LOCK®, LATTICE BRAID®, MILL-RIGHT®, PACK-MASTER®, QUICKBUSHINGS®, QUICKSET®, and SYNTHEPAK® are registered trademarks of Garlock.

# Graphite Packings

## Style 1306

- » Style 1306 is braided from high purity flexible graphite yarns with carbon filament yarns on the corners.
- » The combination of materials and construction gives Style 1306 added abrasion resistance over standard flexible graphite yarn packings.



### SPECIFICATIONS

<b>Construction</b>	LATTICE BRAID® graphite filament
<b>Temperature</b>	-328°F (-200°C) to 850°F (455°C) atmosphere to 1000°F (538°C) in steam
<b>pH range</b>	0-14 (except strong oxidizers)
<b>Pressure</b>	to 500 psi (34 bar) rotary
<b>Shaft speed</b>	to 4,000 fpm (20 m/s) rotary

## STYLE 1300-E

- » Our entry level graphite packing, 1300-E handles high temperature rotary and valve service



### SPECIFICATIONS

<b>Construction</b>	LATTICE BRAID® flexible graphite
<b>Temperature</b>	-328°F (-200°C) to 850°F (455°C) atmosphere to 1200°F (650°C) in steam
<b>pH range</b>	0-14 (except strong oxidizers)
<b>Pressure</b>	to 500 psi (34 bar) rotary to 3,000 psi (200 bar) valves
<b>Shaft speed</b>	to 4,000 fpm (20 m/s) rotary

## STYLE 1333-G

Premium flexible Graphite (FG) packing with field proven performance and reliability. The packing material is reinforced with high purity graphite fiber yarn giving it superiority over lower performing reinforcement materials.



- » Style 1333-G is braided from graphite fiber reinforced flexible graphite yarns and high purity graphite filament yarns to provide high tensile strength and low friction
- » The excellent heat dissipating properties of 1333-G allows our customers to conserve both water and energy
- » Since Style 1333-G can be used in clean, high speed, high temperature applications requiring low leakage rates, our customers also realize a significant savings in inventory investment by using this material in both pumps and valves

### SPECIFICATIONS

<b>Construction</b>	Offset square flexible graphite braid reinforced with a graphite dispersion
<b>Temperature</b>	-328°F (-200°C) to 850°F (455°C) atmosphere to 1200°F (650°C) in steam
<b>pH range</b>	0-14 (except strong oxidizers)
<b>Pressure</b>	to 600 psi (41 bar) rotary to 4,000 psi (275 bar) valves
<b>Shaft speed</b>	to 4,800 fpm (23 m/s) rotary

\* Style 1333-G Square is available upon request



# Expanded PTFE and Graphite Fiber

## STYLE 5100 GFO® PACKING

- » Braided compression packing made from 100% GFO® fiber provides consistently high performance in a wide range of applications
- » Unlike other PTFE/graphite packing, only those made with GFO® fiber, with its 20+ year history of trouble-free performance, deliver an unmatched level of assurance, confidence and easy handling
- » As a proud Seal of Assurance member, Garlock produces Style 5100 to the exacting standards that allow an operation to benefit from reduced maintenance and inventory costs
- » Style 5100 is non-contaminating so it will not contaminate the end product
- » Remember, if it does not say 100% GFO® on the packing, then it is not genuine GFO®



### SPECIFICATIONS

<b>Construction</b>	GFO® with Silicone lubrication
<b>Temperature</b>	-200°F (-130°C) to 550°F (288°C)
<b>pH range</b>	0-14**
<b>Pressure</b>	to 300 psi (20 bar) rotary/centrifugal to 2,000 psi (138 bar) valves
<b>Shaft speed</b>	to 4,800 fpm

\*\* Not recommended for Chlorine service GFO is a registered trademark of WL Gore.

## STYLE G-200

- » Style G-200 offers low friction for energy savings
- » Excellent sealability against abrasives for improved reliability, temperature and chemical resistance for longer packing life
- » G-200 is a good choice for high speed rotary service



### SPECIFICATIONS

<b>Construction</b>	LATTICE BRAID® graphite filament lubricated with graphite dispersion
<b>Temperature</b>	-328°F (-200°C) to 850°F (455°C) atmosphere to 1200°F (650°C) in steam
<b>pH range</b>	0-14 (except strong oxidizers)
<b>Pressure</b>	to 500 psi (34 bar) rotary
<b>Shaft speed</b>	to 4,000 fpm (20 m/s)

#### WARNING:

Properties/applications shown throughout this brochure are typical. Your specific application should not be undertaken without independent study and evaluation for suitability. For specific application recommendations consult Garlock. Failure to select the proper sealing products could result in property damage and/or serious personal injury.

Performance data published in this brochure has been developed from field testing, customer field reports and/or in-house testing.

While the utmost care has been used in compiling this brochure, we assume no responsibility for errors. Specifications subject to change without notice. This edition cancels all previous issues. Subject to change without notice.

GARLOCK is a registered trademark for packings, seals, gaskets, and other products of Garlock.

# Valve Packing: Fugitive Emissions Control Products

## WHAT TO DO FOR EFFICIENT FUGITIVE EMISSION CONTROL?

Fugitive emissions from valves are the largest contributor to the fugitive emissions of any plant processing volatile organic compounds (VOC) and hazardous air pollutants (HAP). A majority of the fugitive emissions in petrochemical plants are a result of valve gland leakage. This leakage, in most cases, can be prevented with correct maintenance and with the use of high performance compression packing.

## WHAT IS THE ENHANCED LEAK DETECTION AND REPAIR PROGRAM AND HOW CAN OUR PRODUCTS AND EXPERTISE HELP?

Enhanced LDAR is used by the Environmental Protection Agency (EPA), describing actions that plants must take to attain and go beyond regulatory compliance. Enhanced LDAR covers a number of elements such as quality control, training, monitoring, repairs and most notably, equipment upgrades.

These upgrades include, requiring use of "low leak"\* or low emission (LE) compression packing. Garlock pioneered the development of (LE) packing in the 1980s and has continued to refine and widen its product offering through the years. Our sealing solutions meet or exceed the requirements of many recognized international standards and we offer our limited performance warranty on these products. Our highly trained technical support experts can help you find the most appropriate solution and supply precious advice.

## WARRANTY

Garlock will warranty that these sets will provide leakage rates no greater than 100 ppm above background in VOC service for a period of 5 years, when installed and maintained in accordance with Garlock installation instructions and warranty conditions\*\*.



\*Low-leak is defined as a valve with stem packing that carries a warranty for 5 years able to deliver 100ppm leak performance. Warranties are generally subject to valve conditions and installation practices.

\*\*For more information, please refer to our Warranty Condition Requirements available on our website.

# Valve Packing: Fugitive Emissions Control Products

## STYLE 1303-FEP

Garlock Style 1303-FEP combines the low emissions performance of engineered sets with the flexibility and convenience that comes with spool stock compression packing.



## SPECIFICATIONS

<b>Construction</b>	High-purity GRAPH-LOCK® flexible graphite and 0.004" INCONEL® filament
<b>Temperature</b>	-328°F (-200°C) to 850°F (455°C) atmosphere; to 1,200°F (650°C) steam**
<b>pH range</b>	0-14 (except strong oxidizers)
<b>Pressure</b>	to 4,500 psi (310 bar)

\*INCONEL® is a registered trademark of Inco Alloys International, Inc.

\*\* For applications over 1,000°F (538°C), please contact Garlock Applications Engineering

## ADVANTAGES & FEATURES

High performance	Style 1303-FEP has been engineered to deliver compliance to the most stringent VOC (volatile organic compounds) and VHAP (volatile hazardous air pollutant) emission regulations.
Easy to use	This single spool stock packing is a quick efficient solution for on the spot field maintenance and repair. It is available in ring sets as well for convenience in planned or scheduled maintenance.
Safety	This style has proven itself as class leading sealing solution and is well recognized in hydrocarbon and chemical processing industries. It is a reliable solution, ideally suited for valve stem sealing and is fire safety tested.

## INDEPENDENT LAB TEST RESULTS

API-622 2nd Ed. - Fugitive Emission Test	Average Leakage	Maximum Leakage	Required Adjustment
	2 PPMv	8 PPMv	0

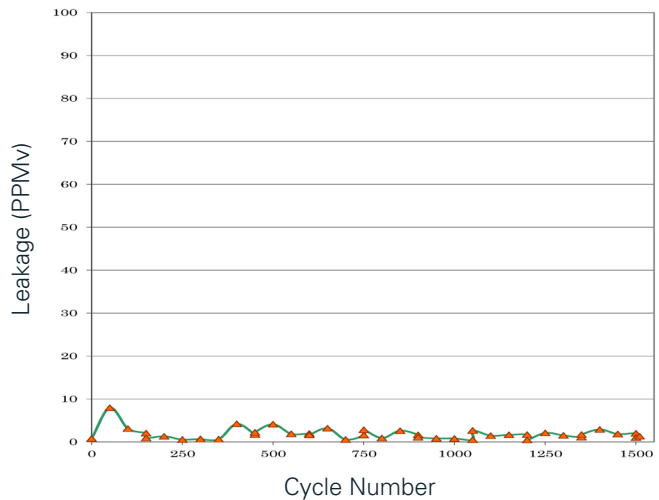

## ENVIRONMENTAL VALUE

- » This Garlock valve stem packing product has been tested to Fugitive Emission Standards ISO-15848-1 and API 622 2nd Ed., demonstrating Garlock's superior sealing performance.

# Valve Packing: Fugitive Emissions Control Products

## GARLOCK STYLE 212-ULE VALVE STEM SPOOL PACKING

Optimized performance and planning with a convenient easy to use spool box product. 212-ULE offers the fire safety and chemical resistance of our other low emission valve stem packing products.



## HOW TO INSTALL 212-ULE\*

When packing a valve, pack 2 rings of "Packing B", then one ring of "Packing A", then 2 additional rings of "Packing B", giving you a B-B-A-B-B configuration (or 212). This minimizes valve emissions and reduces torque actuation forces. For stuffing boxes deeper than 5 rings, please order Garlock Style 1998-EZ Bushing.

## IDEAL SET CONFIGURATION

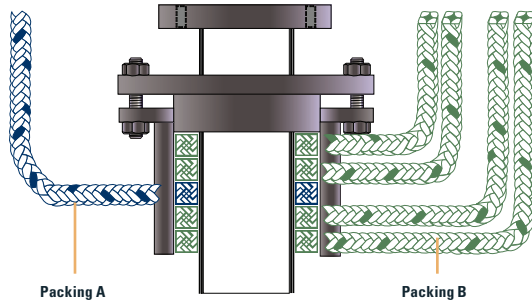

## 212-ULE BOX ORDERING INFORMATION

Packing Cross Section	Average Number of Valves Packed					Average Stem Diameter	Avg Number of Valves Packed
	Style B		Style A				
	Inches	Ft Lbs	Ft	Lbs			
1/8	65.5	0.8	16.4	0.3	0.375	125	
3/16	127.6	3.6	31.9	0.9	0.625	150	
1/4	98.2	4.3	24.5	0.9	1	75	
5/16	50.7	3.0	12.7	0.8	1.625	25	
3/8	45.2	3.5	11.3	1.0	2.5	15	
7/16	38.6	4.3	9.7	1.0	3.25	10	
1/2	22.3	3.8	5.6	0.7	3.75	5	
9/16	26.5	4.9	6.6	1.2	4.5	5	
5/8	29.5	7.4	7.4	1.5	5	5	

## ADVANTAGES & FEATURES

### Easy to use

Style 212-ULE is easy to cut and install. It is conveniently supplied in a dispenser box package with color coded instructions.

### Lower your costs

Cut inventory dollars and reduce outage schedules without sacrificing performance. Outage planning is easier than ever with 212-ULE box showing the amount of typical valve that can be repacked. A few boxes of different cross section sizes allow for quick response and efficient coverage of outage requirements.

### Low stem friction

Style 212-ULE combines two packing types to lower friction while maintaining optimal sealing performance.

## INDEPENDENT LAB TEST RESULTS

API-622 2nd Ed. - Fugitive Emission Test	Average Leakage	Maximum Leakage	Required Adjustment
	1 PPMv	5 PPMv	0

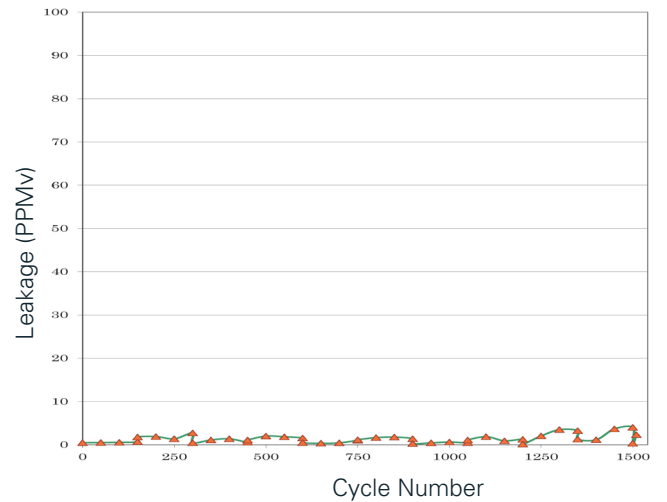

## SPECIFICATIONS

<b>Temperature</b>	-328°F (-200°C) to 1,200°F (650°C) steam • 850°F (455°C) atmosphere
<b>pH range</b>	0-14 (except strong oxidizers)
<b>Pressure, Max</b>	to 4,500 psig (310 bar)

\*NOTE: For applications over 1,000°F (538°C), please contact Garlock Applications Engineering

# Valve Packing: Fugitive Emissions Control Products

## 9000-EVSP LE

Style 9000 EVSP LE is configured to optimize performance in fugitive emission application. This field proven set design allows a precise fit and an easy installation.



## SPECIFICATIONS

<b>Construction</b>	GRAPH-LOCK® rings of high-purity diamond texturized graphite tape, in cup and cone configuration; end rings made from Garlock 1303-FEP
<b>Temperature</b>	-328°F (-200°C) to 850°F (455°C) atmosphere to 1,200°F (650°C) steam
<b>pH range</b>	0-14 (except strong oxidizers)
<b>Pressure</b>	to 10,000 psi plus (690 bar)

## ADVANTAGES & FEATURES

<b>Forgiveness</b>	Our ring set with patented cup and cone design, delivers higher precision fit to optimize field performance.
<b>Cost effectiveness</b>	The EVSP design permits a controlled radial expansion to create an effective seal against both valve stem and bore. This engineered set can be used to seal older more worn valves. Emission compliance can be achieved without necessarily replacing valves or the maintenance expense of bringing the valves back to manufacturer's specifications.
<b>Safety</b>	This Style is fire safety tested and chemical resistant. It is well recognized in hydrocarbon and chemical processing industries as a reliable and ideally suited solution for low emission valve stem sealing.

## ENVIRONMENTAL VALUE

- » This Garlock valve stem packing product has proven itself to be an efficient and reliable solution to improve air quality by lowering VOC (volatile organic compounds) and VHAP (volatile hazardous air pollutant) emissions.

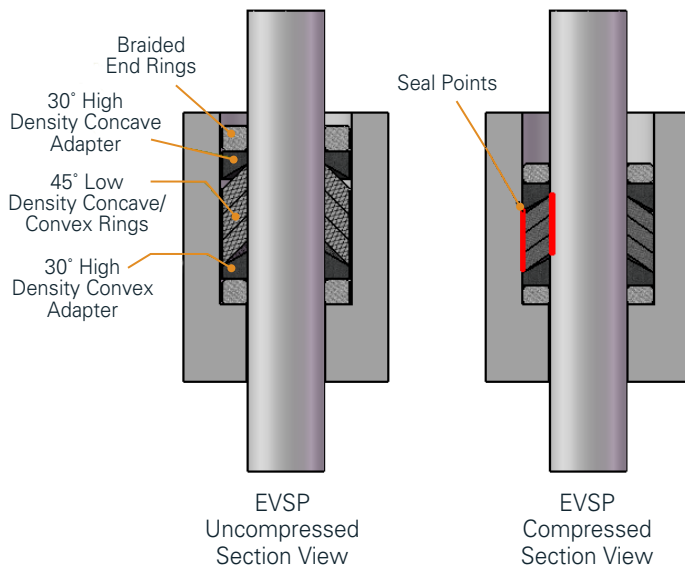

## Fugitive Emissions Standard compliance:

ISO-15848-1    API-622, 2<sup>nd</sup> Edition

\* Patent #4,328,974

# Valve Packing: Fugitive Emissions Control Products

## 9001-QUICKSET® LE - LOW EMISSIONS

- » This QUICKSET® version is configured to offer the best fugitive emissions sealing performance in shallow stuffing boxes
- » The field proven Garlock "cup and cone" design permits a controlled radial expansion to create an effective seal against both valve stem and bore.
- » This engineered set is well suited to seal older or more worn valves. Emissions compliance can often be achieved without the expenses of bringing the valves back to manufacturer's specifications.



### SPECIFICATIONS

<b>Construction</b>	Die-formed cup and cone rings combined with die-formed, high-density Style 1303-FEP end rings with active and passive corrosion inhibitors
<b>Temperature</b>	-328°F (-200°C) to 850°F (455°C) atmosphere to 1,200°F (650°C) steam
<b>pH range</b>	0-14 (except strong oxidizers)
<b>Pressure</b>	to 10,000 psi plus (690 bar)

### STANDARD COMPLIANCE:

- » API-622 2<sup>nd</sup> Edition: Fire Tested to API-589, API-607\*

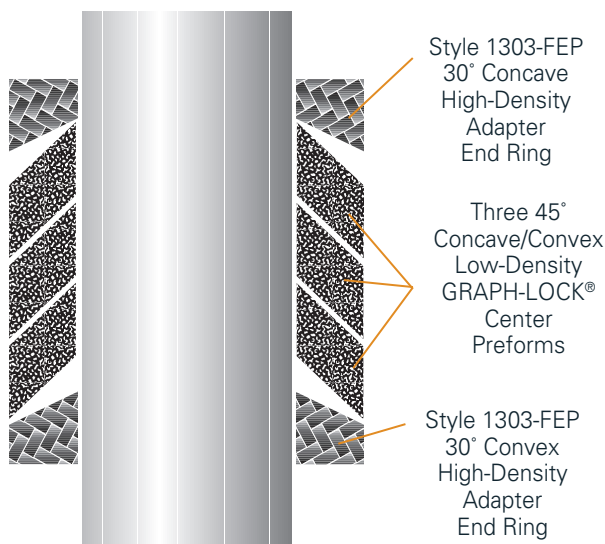

9001 QUICKSET® LE Ring Arrangement

\*API-607 4<sup>th</sup>. Ed.

## STYLE 1998 EZ BUSHING

*"Bushing on a Spool"*

- » Style 1998 EZ-Bushing was designed for use as a bushing material with the convenience of being readily available in bulk form and custom cut to length on site
- » This not only minimizes downtime but also reduces inventory investment of custom machined bushings
- » Low stem friction
- » Environmentally friendly packaging
- » Pack stuffing boxes without ordering special carbon or stainless bushings
- » Easily removed from stuffing box
- » Easy to use dispensing box



### SPECIFICATIONS

<b>Construction</b>	INCONEL® reinforced
<b>Temperature</b>	to 850°F (455°C)
<b>pH range</b>	2-11

\*NOTE: Recommended for use as a bushing material only

# Valve Packing: Power Generation, Steam

## 9001-QUICKSET® DT

- » QUICKSET® version configured to offer consistent sealing performance over a wide temperature range in shallow stuffing boxes.
- » The compact design of QUICKSET® helps reduce valve stem friction over other taller set designs, resulting in a more efficient, less costly use of plant resources to control actuated valves.



### SPECIFICATIONS

<b>Construction</b>	Die-formed cup and cone rings combined with die-formed, high-density Style 1303-DRY end rings with active and passive corrosion inhibitors.
<b>Temperature</b>	-328°F (-200°C) to 850°F (455°C) atmosphere to 1,200°F (650°C) steam
<b>pH range</b>	0-14 (except strong oxidizers)
<b>Pressure</b>	to 10,000 psi plus (690 bar)

### STANDARD COMPLIANCE:

- » Fire Tested to API-589, API-607\*

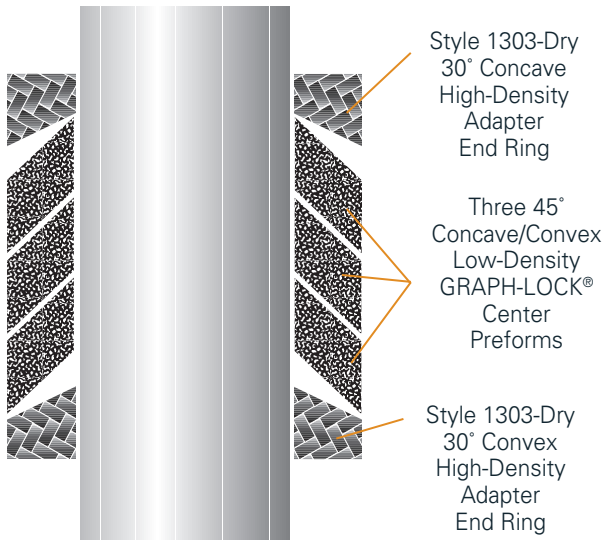

9001 QUICKSET® DT Ring Arrangement

\*API-607 4<sup>th</sup>. Ed.

## 9000-EVSP

- » Field proven Garlock “Cup and Cone” design allowing radial expansion and conformability to accommodate valves that may not be in ideal condition.
- » Excellent oxidation resistance in high temperature steam applications.
- » Well suited to seal new and older control valves. Desired operational performance can often be achieved without the expenses of bringing the valves back to manufacturer’s specifications.
- » Plant resources to control actuated valves can therefore be used more efficiently and economically.



- Choice of end rings: Style 98 (general service); Styles G-700 or 1398 (power generation) ; Style 1303 Dry for maximum range of temperature.

### SPECIFICATIONS

<b>Construction</b>	Die-formed cup and cone rings combined with die-formed, high-density Style 98 end rings with active and passive corrosion inhibitors.
<b>Temperature</b>	-328°F (-200°C) to 850°F (455°C) atmosphere to 1,200°F (650°C) steam
<b>pH range</b>	0-14 (except strong oxidizers)
<b>Pressure</b>	to 10,000 psi plus (690 bar)

# Valve Packing: Power Generation, Steam

## STYLE 1298

Your premium sealing solution for steam pressure service.

- » This packing will offer a steady performance over a wide range of temperature and pressure for your power generation application. It will stay conformable, flexible and will seal even under high glen load pressure.
- » The combination of high ends components used in the style 1298 allows the packing to conform to stem and bore to seal efficiently for a longer period. The Individually impregnated yarns enhance sealability, resistance to chemical and eliminate possible stem scoring to improve the equipment operation and life.
  - › Remains dimensionally stable at high temperatures
  - › Great resistance to chemical and solvent
  - › Improve equipment operation and life.



## SPECIFICATIONS

<b>Construction</b>	PBI yarn with encapsulated wire reinforced (Inconel) braided over a flexible LATTICE BRAID® carbon yarn core
<b>Temperature</b>	to 850°F (455°C) atmosphere to 1,200°F (650°C) steam
<b>pH range</b>	0-12
<b>Pressure</b>	to 4,500 psi (310 bar)

## STYLE 1200PBI

A field proven product designed for steam pressure service in the power generation industry.

- » Constructed with Inconel wire encapsulated in fiber that improves equipment operation and life.
- » The flexible surface allows for the packing to conform to stem and bore to seal efficiently for a longer period.
- » Remains dimensionally stable at high temperatures
- » Excellent resistance to chemicals and solvents.



## SPECIFICATIONS

<b>Construction</b>	PBI yarn with encapsulated wire reinforced (Inconel) braided over extruded plastic core with wire reinforcement (Inconel)
<b>Temperature</b>	to 850°F (455°C) atmosphere to 1,200°F (650°C) steam
<b>pH range</b>	0-12 (except strong oxidizers)
<b>Pressure</b>	to 2,500 psi plus (172 bar)

Inconel is a registered trademark of Special Metals Corporation group of companies

# Valve Packing: Power Generation, Steam

## STYLE 5882 LOW FRICTION PACKING

The power generation industry is challenged with achieving leak free valve sealing combined with responsive and smooth valve actuation. Our 5882 Series product offering addresses these industry needs with an easy to install, stable, low friction valve stem packing.



## OPTIMIZING FRICTION & STRUCTURAL STABILITY

Low friction products offerings:

- » Garlock Style 5882 is constructed from a high quality carbon fiber core and a PTFE shell, optimizing the low friction qualities of PTFE and the structural integrity of high quality carbon fiber. Packing is available in spool stock and die formed ring sets for end user convenience.
- » Style 5882 LSP is a combination set of GRAPH-LOCK® and Style 5882 rings for nuclear applications.

## ADVANTAGES

<b>Low Friction</b>	Up to 20% lower friction than leading competing products made from innovative materials and technology.
<b>Customizable: Material &amp; Bushings</b>	All standard sizes available. These products can be formed to almost any dimensions. We offer custom fabricated carbon bushings for optimizing box depth and set performance.
<b>Simplified Planning</b>	Planning for an outage? Formed sets provide you with a convenient way to know you have exactly what you need.
<b>Quality</b>	Use of highest quality and purity materials combined with our workmanship allows us to provide consistent and reliable products for safety and performance.

## BENEFITS

- » Potential cost reduction by reducing size of required actuator
- » In service solution for undersized actuators in trouble applications
- » Convenience of die formed or mandrel cut spool stock

## LOW FRICTION TEST RESULTS

- » Gland stress of 3560 psi
- » Representative 1.5 cycle from 250 cycle test. Full test results available through Garlock Engineering
- » No pressure

## CONFIGURATIONS

- » **Continuous**
  - Style 5882 Spool
- » **Discrete**
  - Style 5882 die formed, bevel cut rings
  - Style 5882 LSP
    - Die formed engineered graphite
    - Style 5882 end rings

## IDEAL FOR:

- AOV (Air Operated Valves)
- » Steam
  - » Water
  - » Process Control
  - » Air

## SPECIFICATIONS

<b>Construction</b>	PTFE fiber over braided carbon core
<b>Temperature</b>	-200°F (-130°C) to 550°F (288°C)
<b>pH range</b>	0-14
<b>Pressure</b>	to 3500 psi (242 bar) in valves**

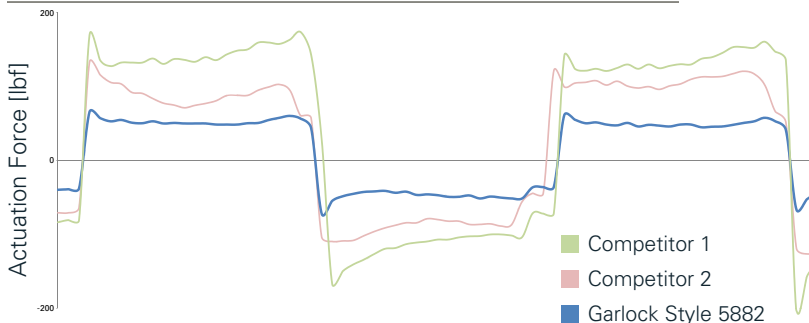

# Valve Packing Performance Enhancement Accessories

## HIGH PURITY CARBON BUSHINGS

Our testing has determined that the optimal number of rings to seal a valve stem is between 5 and 7. Any less than 5 rings increases the chance of leaks, any more than 7 puts too much drag on the stem. Garlock uses high purity carbon bushings or Style 1998 EZ-Bushing to shorten deep stuffing boxes like those that are typically found in older valves. When combined with our radially expanding valve stem solutions, our high purity bushings allow excellent sealing with low actuation force which enables old, manual valves to be fit with air actuators and seal like new. Further, our bushings are made to such exacting material and dimensional standards that they can even be certified for nuclear service.

Bushings can also be made from 1303-DRY. While this approach adds some friction to the stem, it is an ideal choice when the valve stuffing box depth cannot be determined prior to repacking.

## LIVE LOADING HARDWARE

Even with its densified graphite construction, an EVSP set can consolidate by up to 2% over its service life. While this is not an issue for valves that can be easily monitored and adjusted, it does pose a problem for valves that are off the routine maintenance path. Additionally some service conditions, like severe temperature swings or frequent opening and closing, can accelerate consolidation. Garlock's solution for those types of applications is Live Loading.

Live Loading can compensate for packing consolidation of up to 3% and, when used with EVSP, can virtually eliminate the need for adjustment. It does not however, put a constant compressive force on the seal. If you use live loading with a braided packing like 1303-FEP, it will significantly extend the time between adjustments but adjustments will still be required.

We stock a wide range of spring washers so we can respond to most needs within 48 hours.

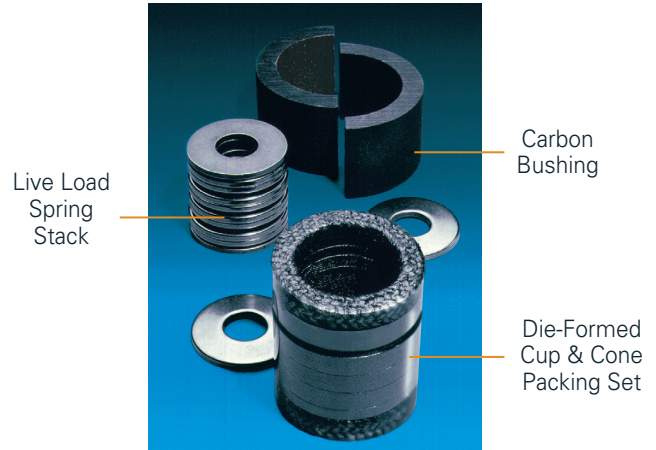

## RECOMMENDED IN THE FOLLOWING CONDITIONS:

- » Valves with difficult access
- » High degree of thermal cycling
- » "Critical" to operation of facility
- » Frequently actuated
- » Control valves
- » Controlled emissions levels
- » High levels of packing consolidation

## WARNING:

Properties/applications shown throughout this brochure are typical. Your specific application should not be undertaken without independent study and evaluation for suitability. For specific application recommendations consult Garlock. Failure to select the proper sealing products could result in property damage and/or serious personal injury.

Performance data published in this brochure has been developed from field testing, customer field reports and/or in-house testing.

While the utmost care has been used in compiling this brochure, we assume no responsibility for errors. Specifications subject to change without notice. This edition cancels all previous issues. Subject to change without notice.

GARLOCK is a registered trademark for packings, seals, gaskets, and other products of Garlock.

# Nuclear Applications

## STYLE G-700

The Choice for Critical Devices

- » When used as end rings together with high purity GRAPH-LOCK® rings, G700 is ideal for critical valve applications\*\* in nuclear and power generation industries
- » Tested by independent laboratories; compliant with:
  - » MIL-P-24583B (SH)
  - » General Electric Spec. D50YP12 Rev. 2
- » Contains no PTFE or other lubricants
- » Non-abrasive; very low coefficient of friction
- » Will not fray



## GRAPH-LOCK® N STYLE 1398

Garlock style 1398 is a nuclear grade braided flexible graphite valve stem packing. The graphite-containing Inconel filament adds reinforcement to the packing to handle BWR (General Electric) and PWR (Westinghouse, Combustion Engineering and Babcock Wilcox) valve service conditions as an end-ring material for use with other graphite products.



Style 1398 can also be used as a bushing material in the bottom of the stuffing box to fill excess depth not needed for sealing components.

### SPECIFICATIONS

<b>Construction</b>	Highest grade graphite filament with an exclusive graphite dispersion, in LATTICE BRAID® construction
<b>Temperature</b>	-328°F (-200°C) to 1,200°F (650°C) steam to 1,625°F (900°C) in free oxygen-exclusive environments such as nitrogen and carbon dioxide 850°F (455°C) atmosphere
<b>pH range</b>	0-14 (except strong oxidizers)
<b>Pressure</b>	to 4,000 psi (275 bar) plus, when used with GRAPH-LOCK® center rings

### SPECIFICATIONS

<b>Construction</b>	
<b>Temperature</b>	-328°F (-200°C) to 950°F (510°C)
<b>pH range</b>	
<b>Pressure</b>	to 3,000 psi (207 bar)

\* INCONEL® is a registered trademark of Inco Alloys International, Inc.  
 \*\* Used as end rings ONLY. Not designed to be a stand alone packing, must incorporate flexible graphite packing center rings.



# Water Conservation Products

## HydraJust™

### STYLE 8091

#### Engineered Sealing System

Designed for industrial pumping applications with high potential to reduce water consumption. Can also withstand conditions that would prevent use or create premature wear and catastrophic failure of mechanical seals.



#### THE BEST OPTION FOR SLURRY SERVICE

Garlock has created a long life seal that will increase reliability and process yield while conserving water and energy. Hydra-Just™ combines the best of both worlds; like a mechanical seal, Hydra-Just™ provides low leak, no dilution service and saves energy and water because of the low friction design. Like conventional packing, Hydra-Just can accommodate system upsets and is not subject to catastrophic failure.

#### THE CHOICE FOR WATER REDUCTION

Until now, mechanical seals were the choice for water and energy saving. As a rule of thumb, a mechanical seal requires 1 US gallons per minute per inch of shaft Diameter. Hydra-Just™ runs with 98% less water than mechanical seals requiring as little as 3 US gallons per hour. To put this in context, replacing a mechanical seal that requires 2 USGPM of flush with Hydra-Just will save over 1,000,000 US gallons of water per pump.

#### BENEFITS

- » Reduction of flush water and associated costs
- » Reduction of product dilution
- » Reduction of water evaporation costs
- » Longer seal life
- » Leak free service potential
- » Low maintenance-quick turnaround
- » Environmentally friendly

#### DESIGNED FOR OUTAGE-TO-OUTAGE PERFORMANCE

This robust seal enables users to increase profitability through improved process yield. The process exclusive design of the Hydra-Just™ ensures a seal with the versatility to handle a wide range of system upsets and excel in abrasive slurries.

#### EASY TO INSTALL

Hydra-Just™ customers can realize production increases by getting back on line faster. The components of the Hydra-Just™ allow the seal to be installed without uncoupling the motor.

# Water Conservation Products

## STYLE 8093 DSA

The Best Option for Clean Service  
Garlock's DSA seal is the best available sealing technology for clean media. This seal saves water in that it runs without a flush, improves output by lasting longer than conventional packings and saves money in that it is significantly less expensive than a mechanical seal. Combining these attributes make the Garlock DSA the ideal choice for condensate, water or boiler feed pumps.



## THE RIGHT CHOICE FOR WATER SAVINGS

DSA enables customers to save millions of gallons of water every year. The unique design completely eliminates the need for flush water.

## EASY TO INSTALL

DSA customers can realize production increases by getting back on line faster. The split design of the seal enables installation in under an hour.

## SPECIFICATIONS

<b>Construction</b>	Typical set: gasket spacer, braided rings, flexible graphite adapters and preforms
<b>Media</b>	Condensate, boiler feed water, light paper stock, white water, feed water
<b>Temperature</b>	to 500°F (260°C)
<b>pH range</b>	0-14* (except strong oxidizers)
<b>Shaft speed</b>	to 4,000 fpm plus (20 m/s)
<b>Pressure</b>	to 500 psi (35 bar)

\* Depends on braid choice

## FLUSH-GARD™ SEAL

Reduces flush water

- » Throat cavity bushing reduces flush water consumption
- » Extends equipment life by protecting sleeve and packing from media attack
- » Split design installs easily, without equipment disassembly
- » Recommended for stock pumps, agitators and other applications handling solid/liquid mixtures



## SPECIFICATIONS

<b>Construction</b>	Graphite-filled PTFE
<b>Temperature</b>	-250°F (-157°C) to 450°F (232°C)
<b>Surface speed</b>	to 2,500 fpm (12.7 m/s) <sup>†</sup>
<b>pH range</b>	0-14 (except strong oxidizers)





\* U.S. Patent #4,498,681; Canada Patent #1,271,788

\*\* For maximum strength and density, install with slots toward shaft; for maximum gland water flow, install with slots away from shaft.

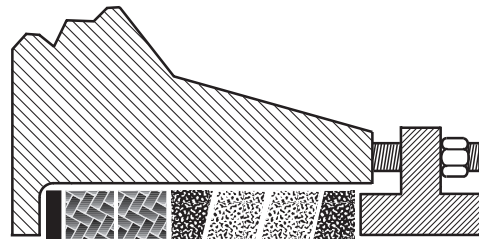
<sup>†</sup> Above 2,500 fpm, consult Garlock.

<sup>††</sup> INCONEL is a registered trademark of Inco Alloys International, Inc.



-  Gasket spacer (Style 3530 or G-9900)
-  Braided ring (Style 98, 5000 or 8921-K)
-  Low density GRAPH-LOCK® preforms
-  High density GRAPH-LOCK® adapters

# Carbon Packings

Garlock Premium Carbon Packing offer field proven performance, versatility and longevity. The distinctive design using high purity staple carbon fiber results in carbon packing that can conform to shape better compared to continuous carbon filament packing. This better fit contributes to improved sealing, lower friction and greater longevity.

## STYLE 98

The best choice for high-temperature service

- » Low coefficient of friction for longer equipment life
- » High thermal conductivity means process runs cooler, and packing lasts longer
- » Withstands wide variety of chemicals
- » Low chloride certification available
- » Versatile, can be used in both pumps and valves in a wide range of other applications



## STYLE 5000

- » The best choice for non-contaminating slurry service
- » Low abrasion and high chemical resistance for long service
- » Ideal where contamination is prohibited, as in pulp and paper industry
- » Low chloride certification available
- » Style 5000-PBI\* offers extra abrasion resistance
- » Excellent for low friction valve stem requirements



## SPECIFICATIONS

<b>Construction</b>	LATTICE BRAID® carbon fiber
<b>Media</b>	Acids, strong caustics, hot oils, solvents, boiler feed, condensate water
<b>Equipment</b>	Centrifugal pumps, agitators, ball, globe, gate and plug valve stems, oil drilling and down-hole tools
<b>Temperature</b>	-328°F (-200°C) to 850°F (455°C) atmosphere to 1,200°F (650°C) steam
<b>pH range</b>	0-14 (except strong oxidizers)
<b>Shaft speed</b>	to 4,000 fpm plus (20 m/s)
<b>Pressure</b>	to 500 psi (35 bar) rotary/centrifugal to 2,500 psi (173 bar) valves

## SPECIFICATIONS

<b>Construction</b>	LATTICE BRAID® carbon fiber impregnated with PTFE, high temperature break-in lube
<b>Media</b>	Acids, strong caustics, slurries
<b>Equipment</b>	Slip joints, mixers, agitators, reactors, autoclaves, centrifugal pumps, turbines
<b>Temperature</b>	-328°F (-200°C) to 600°F (315°C)
<b>pH range</b>	0-14 (except strong oxidizers)
<b>Shaft speed</b>	to 3,000 fpm plus (15 m/s)
<b>Pressure</b>	to 500 psi (35 bar) rotary/centrifugal



# Carbon Packings

## CARBAE™ 105 & 108

High performance, low cost

- » Excellent cost / use ratio
- » Ideal for most industrial equipment
- » Compatible with a wide range of chemicals
- » Easy to install and remove



### STYLE 105 SPECIFICATIONS

<b>Construction</b>	95% carbon assay fiber with PTFE coating
<b>Media</b>	Acids, caustics, slurries
<b>Equipment</b>	Centrifugal pumps, mixers, agitators
<b>Temperature</b>	-328°F (-200°C) to 600°F (316°C) atmosphere 1,200°F (650°C) steam
<b>pH range</b>	0-14 (except strong oxidizers)
<b>Shaft speed</b>	to 3,000 fpm plus (15 m/s)
<b>Pressure</b>	to 500 psi (35 bar) rotary/centrifugal



### STYLE 108 SPECIFICATIONS

<b>Construction</b>	95% carbon assay fiber with graphite dispersion
<b>Media</b>	Acids, caustics, hot oils, solvents, boiler feed, condensate water
<b>Equipment</b>	Centrifugal pumps, valves, agitators
<b>Temperature</b>	-328°F (-200°C) to 850°F (455°C) atmosphere 1,200°F (650°C) steam
<b>pH range</b>	0-14 (except strong oxidizers)
<b>Shaft speed</b>	to 4,000 fpm plus (20 m/s)
<b>Pressure</b>	to 500 psi (35 bar) rotary/centrifugal to 2,500 psi (173 bar) valves <sup>†</sup>

<sup>†</sup> No pressure limits have been determined when CARBAE™ 108 is combined as end ring material with die-formed GRAPH-LOCK® center rings in valve installations.

Note: CARBAE™ 108 can be certified to contain less than 200 ppm leachable chlorides on request.

# Soot Blower Sets

## EXCEPTIONAL RELIABILITY

- » Rugged materials for extended service life
- » INCONEL<sup>™</sup> wire reinforcement withstands high temperatures and pressures
- » Die-formed rings ensure accurate fit and simple installation
- » Efficient conical design allows outstanding sealing at low gland loads
- » Standard sizes for Diamond Power, Copes Vulcan and other soot blowers

### TORNADO PACK™ F1

<b>Construction</b>	Style 127-AFP: INCONEL® wire reinforced carbon over homogeneous core
<b>Temperature</b>	to 650°F (345°C) atmosphere 1,200°F (650°C) steam

### TORNADO PACK™ F3

<b>Construction</b>	Style 1298: INCONEL® wire reinforced PBI <sup>†††</sup> over carbon yarn core
<b>Temperature</b>	to 850°F (455°C) atmosphere 1,200°F (650°C) steam

### TORNADO PACK™ F5

<b>Construction</b>	Style 1303-FEP: INCONEL® wire reinforced flexible graphite
<b>Temperature</b>	to 850°F (455°C) atmosphere 1,200°F (650°C) steam

### GRAPH-LOCK® SETS

<b>Construction</b>	Premium density GRAPH-LOCK® center rings (87.5 lbs/ft <sup>3</sup> [1,400 kg/m <sup>3</sup> ]) with 1303-FEP or 98 end rings
<b>Temperature</b>	to 850°F (455°C) atmosphere 1,200°F (650°C) steam

# General Service Packings

## SYNTHEPAK® PACKINGS

Superior performance

- » Unique spun synthetic fiber; ideal replacement for asbestos
- » Excellent for pumps, valves, rods, plungers, rams, expansion joints
- » Reduction in shaft and sleeve wear lowers operational costs
- » Versatile, multi-use packing means lower inventory stocking costs
- » See Styles 8909, 8913, 8921-K, 8922, 8922-PBI on pages 20-21 for specifications

## STYLE 1925

Premium performance

- » Innovative blend of two yarns:
  - » Fiber-infused PTFE yarns offer abrasion resistance and thermal stability
  - » Exclusive SYNTHEPAK®\* yarns retain flexibility and resilience; ensure even load distribution
- » Longer packing and equipment life mean significant cost savings



## STYLE 1965 & 1965-K

Exclusive construction highly effective for sealing slurry media found in mining

- » Protects machinery's critical components from abrasive media
- » Lowers maintenance and sealing element expenditures
- » Product does not extrude and lasts longer in service
- » Material flexibility and easy handling mean faster change-out times
- » Non-contaminating components keep end product and pump area clean
- » Shock resistant withstanding cavitation, pressure surges and other system upsets
- » Increased thermal stability conserves water



## SPECIFICATIONS

<b>Construction</b>	LATTICE BRAID® fiber-infused PTFE yarns and SYNTHEPAK® yarns with PTFE dispersion and snow white petroleum break-in lube
<b>Equipment</b>	Pumps
<b>Temperature</b>	-450°F (-270°C) to 500°F (260°C)
<b>pH range</b>	1-13
<b>Shaft speed</b>	to 2,500 fpm (12 m/s)
<b>Pressure</b>	to 300 psi (20 bar) rotary/centrifugal

\* Patent #4,994,303

## SPECIFICATIONS

**Construction** LATTICE BRAID® fiber-infused PTFE yarns\* with graphite and SYNTHEPAK® yarns, PTFE dispersion and snow white petroleum. 1965-K with p-aramid reinforcement

<b>Equipment</b>	Pumps
<b>Temperature</b>	-450°F (-270°C) to 500°F (260°C)
<b>pH range</b>	1-13
<b>Shaft speed</b>	to 2,500 fpm (10 m/s)
<b>Pressure</b>	to 600 psi (41 bar) rotary/centrifugal

\* Patent #4,994,303

# PTFE Packings

PTFE compression packing is known for its exceptionally high resistance to chemicals and low friction.

## STYLE 5888

Valve stem packing with superior chemical resistance

- » High density, dimensionally stable—very little water absorption
- » Ideal for valve and slower shaft speed applications
- » PTFE dispersion ensures a low friction finish and prevents leakage through the braid
- » Resistant to most chemicals



### SPECIFICATIONS

<b>Construction</b>	LATTICE BRAID® continuous filament PTFE braid with PTFE dispersion
<b>Equipment</b>	Check and needle valve stems, reciprocating rods, rams and plungers and rotary applications
<b>Temperature</b>	-450°F (-270°C) to 500°F (260°C)
<b>pH range</b>	1-14
<b>Shaft speed</b>	to 1,000 fpm plus (5 m/s)
<b>Pressure</b>	to 300 psi (20 bar) rotary/centrifugal to 2,000 psi (138 bar) valves

## STYLE 5889

Chemically resistant packing for pumps and rotary equipment

- » Preshrunk to avoid packing wear and shaft scoring
- » Soft, flexible but very non-porous
- » Excellent choice for rotary shaft service



### SPECIFICATIONS

<b>Construction</b>	LATTICE BRAID® continuous filament PTFE braid with PTFE dispersion and inert break-in lube
<b>Equipment</b>	Expansion joints, reciprocating rods, rams, plungers, rotary service
<b>Temperature</b>	-450°F (-270°C) to 500°F (260°C)
<b>pH range</b>	1-14*
<b>Shaft speed</b>	to 1,500 fpm plus (8 m/s)
<b>Pressure</b>	to 300 psi (20 bar) rotary/centrifugal

\* Not recommended for chlorine service

## STYLE 5904

Food grade packing

- » Ideal for food processing applications
- » Pliable, wear-resistant and dimensionally stable
- » Resists most caustic media
- » Rugged and non-toxic
- » Ingredients conform to USDA requirements and meet FDA Title 21 CFR 172.878, 177.1550, 178.3570 and 178.3620(a)



### SPECIFICATIONS

<b>Construction</b>	LATTICE BRAID® PTFE filament
<b>Equipment</b>	Pumps, dryers, cookers, blenders, mixers and other centrifugal rotary food processing equipment
<b>Temperature</b>	-450°F (-270°C) to 500°F (260°C)
<b>pH range</b>	1-14
<b>Shaft speed</b>	to 1,500 fpm plus (8 m/s)
<b>Pressure</b>	to 300 psi (20 bar) rotary/centrifugal

#### WARNING:

Properties/applications shown throughout this brochure are typical. Your specific application should not be undertaken without independent study and evaluation for suitability. For specific application recommendations consult Garlock. Failure to select the proper sealing products could result in property damage and/or serious personal injury.

Performance data published in this brochure has been developed from field testing, customer field reports and/or in-house testing.

While the utmost care has been used in compiling this brochure, we assume no responsibility for errors. Specifications subject to change without notice. This edition cancels all previous issues. Subject to change without notice.

GARLOCK is a registered trademark for packings, seals, gaskets, and other products of Garlock.

# Specialty Synthetic Fiber Packings

## STYLE 5200

- » The problem with most aramid fiber packings is that they are designed for strength, not sealability
- » That's what makes our style 5200 different from other aramid packings; we incorporate a PTFE lubrication system that makes a better pump shaft seal
- » The result is that less abrasive material makes it into the stuffing box so that pumps packed with 5200 can stay in service longer and help our customers realize the benefits that come from increased process yield and improved reliability



### SPECIFICATIONS

<b>Construction</b>	LATTICE BRAID® Aramid filament lubricated with a PTFE
<b>Temperature</b>	-420°F (-250°C) to 500°F (260°C)
<b>pH range</b>	2-12
<b>Shaft speed</b>	to 2,500 fpm
<b>Pressure</b>	to 500 psi (35 bar) rotary

## STYLE 1850

- » Style 1850 is produced from KYNOL\* fibers by blending continuous KYNOL filaments with KYNOL staple fibers on the surface of each yarn
- » The yarns as well as the finished braid are impregnated with PTFE dispersion via Garlock's single-end coating process to make a tough, chemically resistant pump packing
- » The finished braid is also coated with a high temperature break-in lubricant

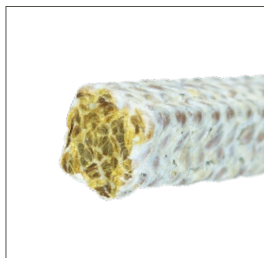

### SPECIFICATIONS

<b>Construction</b>	LATTICE BRAID®
<b>Temperature</b>	-170°F (-110°C) to 550°F (290°C)
<b>pH range</b>	1-13
<b>Shaft speed</b>	to 2,000 fpm
<b>Pressure</b>	to 500 psi (20 bar) rotary/centrifugal

\* KYNOL is a trademark of American KYNOL, inc.

## STYLE 1947

- » Style 1947 is produced from continuous filament NOMEX\* fibers, impregnated with PTFE dispersion via Garlock's single-end coating process
- » The result is a tough, chemically resistant pump packing with good abrasion resistance
- » A surface break-in silicone lubricant is added

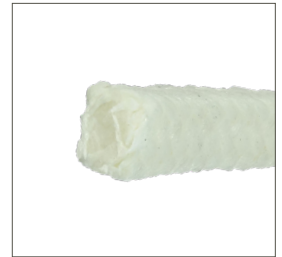

### SPECIFICATIONS

<b>Construction</b>	LATTICE BRAID®
<b>Temperature</b>	-170°F (-110°C) to 550°F (290°C)
<b>pH range</b>	1-13
<b>Shaft speed</b>	to 2,000 fpm
<b>Pressure</b>	to 300 psi (20 bar) rotary/centrifugal

\* NOMEX is a trademark of DuPont.



### WARNING:

Properties/applications shown throughout this brochure are typical. Your specific application should not be undertaken without independent study and evaluation for suitability. For specific application recommendations consult Garlock. Failure to select the proper sealing products could result in property damage and/or serious personal injury.

Performance data published in this brochure has been developed from field testing, customer field reports and/or in-house testing.

While the utmost care has been used in compiling this brochure, we assume no responsibility for errors. Specifications subject to change without notice. This edition cancels all previous issues. Subject to change without notice.

GARLOCK is a registered trademark for packings, seals, gaskets, and other products of Garlock.

# Mild Service Packing

## PACKMASTER® 1

- » The combination of resilient non-asbestos fibers and PTFE offers a true non-contaminating general service packing - ideal where a clean, reliable packing is required
- » Lattice braided synthetic yarns are coated with a PTFE dispersion and a surface coating of break-in lubricant
- » Typical applications are rotary, centrifugal, and reciprocating pumps for such services as mild acids and alkalis, air and dry industrial gases, petroleum and synthetic oils, aromatic and aliphatic solvents, and fluids where non-contamination is required



### SPECIFICATIONS

<b>Construction</b>	LATTICE BRAID®
<b>Temperature</b>	to 500°F (260°C)
<b>pH range</b>	4-10
<b>Shaft speed</b>	to 1,500 fpm
<b>Pressure</b>	to 300 psi (20 bar) rotary/centrifugal

## PACKMASTER® 2

- » A combination of petroleum lubricants and graphite permeate the spun synthetic yarns to produce a packing ideally suited for services in hot and cold water, alcohol, very mild acids and alkalis, and steam
- » Typical services include rotary and centrifugal pumps, reciprocating pumps, and gasketing applications or other non-critical static sealing services



### SPECIFICATIONS

<b>Construction</b>	LATTICE BRAID®
<b>Temperature</b>	to 500°F (260°C)
<b>pH range</b>	4-10
<b>Shaft speed</b>	to 1,500 fpm
<b>Pressure</b>	to 300 psi (20 bar) rotary/centrifugal

## PACKMASTER® 3

- » PACKMASTER 3 is a soft and resilient spun synthetic packing saturated throughout with petrolatum and graphite which offers added sealability
- » This product is particularly suitable for older or worn equipment or scored shafts; the construction is more readily deformable to meet these conditions
- » PACKMASTER 3 is commonly used for distillation units, cooling water systems, diesel and lubricating oils where low to medium pressures are encountered



### SPECIFICATIONS

<b>Construction</b>	Square braid
<b>Temperature</b>	to 500°F (260°C)
<b>pH range</b>	4-10
<b>Shaft speed</b>	to 1,000 fpm
<b>Pressure</b>	to 200 psi (14 bar) rotary/centrifugal

## PACKMASTER® 5

- » This packing is made from aramid fibers that are stronger than steel and will stand up to the toughest abrasive slurries
- » This style is internally lubricated with silicone making it an economical alternative to other aramid based products.



### SPECIFICATIONS

<b>Construction</b>	LATTICE BRAID® Aramid filament lubricated with silicone
<b>Temperature</b>	-420°F (-250°C) to 500°F (260°C)
<b>pH range</b>	2-12
<b>Shaft speed</b>	to 2,500 fpm
<b>Pressure</b>	to 500 psi (35 bar) rotary

For maximum life out of Packmaster 5, use it in conjunction with our Crown Bush throat bushing.

# Mild Service Packing

## PACKMASTER® 6

- » This flexible shock resistant packing has excellent chemical resistance and can stand up in a wide range of rotary applications
- » This universal applicability will translate into better cash flow from reduced inventory and lower training and installation costs.



### SPECIFICATIONS

<b>Construction</b>	Expanded PTFE with graphite and a silicone lubrication
<b>Temperature</b>	-200°F (-130°C) to 550°F (288°C)
<b>pH range</b>	0-14
<b>Shaft speed</b>	to 3,000 fpm
<b>Pressure</b>	to 300 psi (20 bar) rotary/centrifugal

## PACKMASTER® 7

- » PACKMASTER 7 is dimensionally stable and firm, has high density, and is constructed from PTFE continuous filament
- » It's PTFE dispersion provides a low friction surface and prevents leakage through the body of the braid
- » Although designed for slower shaft speeds, it is an excellent valve stem packing; resistant to almost all chemicals (except molten uranium salts), completely free of asbestos and with very little water absorption



### SPECIFICATIONS

<b>Construction</b>	LATTICE BRAID®
<b>Temperature</b>	to 500°F (260°C)
<b>pH range</b>	0-14
<b>Shaft speed</b>	to 1,000 fpm
<b>Pressure</b>	to 300 psi (20 bar) rotary/centrifugal

## PACKMASTER® 8

- » Constructed from continuous PTFE filament, PACKMASTER 8 is dimensionally stable; however it remains relatively soft and very flexible
- » PACKMASTER 8 is treated throughout with PTFE dispersion and an inert high-temperature lubricant
- » This packing is an excellent choice for high speed centrifugal and rotary services in marine and waste/water treatment



### SPECIFICATIONS

<b>Construction</b>	LATTICE BRAID®
<b>Temperature</b>	to 500°F (260°C)
<b>pH range</b>	0-14
<b>Shaft speed</b>	to 1,500 fpm
<b>Pressure</b>	to 300 psi (20 bar) rotary/centrifugal

\*Not recommended for chlorine service

#### WARNING:

Properties/applications shown throughout this brochure are typical. Your specific application should not be undertaken without independent study and evaluation for suitability. For specific application recommendations consult Garlock. Failure to select the proper sealing products could result in property damage and/or serious personal injury.

Performance data published in this brochure has been developed from field testing, customer field reports and/or in-house testing.

While the utmost care has been used in compiling this brochure, we assume no responsibility for errors. Specifications subject to change without notice. This edition cancels all previous issues. Subject to change without notice.

GARLOCK is a registered trademark for packings, seals, gaskets, and other products of Garlock.

# Flush Water Products

## STYLE 1004 LANTERN RING COIL\*

Economical and easy to handle

- » Easily cut with knife or saw, and short lengths splice together, eliminating waste
- » Easy to install\*\* and remove from stuffing box—reduces costly downtime
- » High-purity PTFE offers chemical resistance in a broad range of rotary service

### SPECIFICATIONS

<b>Construction</b>	Wear-resistant high-grade PTFE
<b>Equipment</b>	Pumps
<b>Temperature</b>	to 500°F (260°C)
<b>pH range</b>	0-14 (except strong oxidizers)

## Crown Bush Pump Sealing System

Lower your operating costs

- » Significantly reduce flush water usage
- » Extend packing life
- » Reduce sleeve wear
- » Flush water distribution optimized to keep contaminants away from the gland packing
- » Stainless Steel Crown Bush flow control device resists erosion from abrasive contaminants
- » Non-metallic construction available for non-abrasive duties
- » Split version available

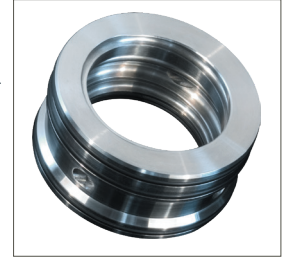

### APPLICATIONS

- » Pulp and paper
- » Mining
- » Mineral Sands
- » Alumina Refining
- » Coal Washing

# Packing Tools

A complete integrated line of U.S. made tools designed to handle your packing maintenance with ease. The unique interchangeability of tips with flex or rigid holders allows a versatility not available elsewhere. Worn or damaged tips may be replaced at minimum cost rather than sacrificing the entire tool.

## FLEXIBLE EXTRACTOR: SIZE F00

- » With non-removable tip
- » F00: Length 7", Shaft Diam 3/32"



## FLEXIBLE EXTRACTOR: SIZES F1, F2, F3

- » With removable tips
- » F1: Length 7", Thread 8-32, Shaft Diam 5/32"
- » F2: Length 11", Thread 1/4-20, Shaft Diam 1/4"
- » F3: Length 14", Thread 1/4-20, Shaft Diam 1/4"



## PACKING TOOLS SET "B" INCLUDES:

- » (2) F1
- » (2) F2
- » (2) F3
- » (1) P7
- » (1) P8
- » (1) P9
- » Wrench
- » (3) C1
- » (3) C2
- » (3) C3
- » (1) W1
- » (1) W2
- » (1) W3
- » Plastic Tool Box

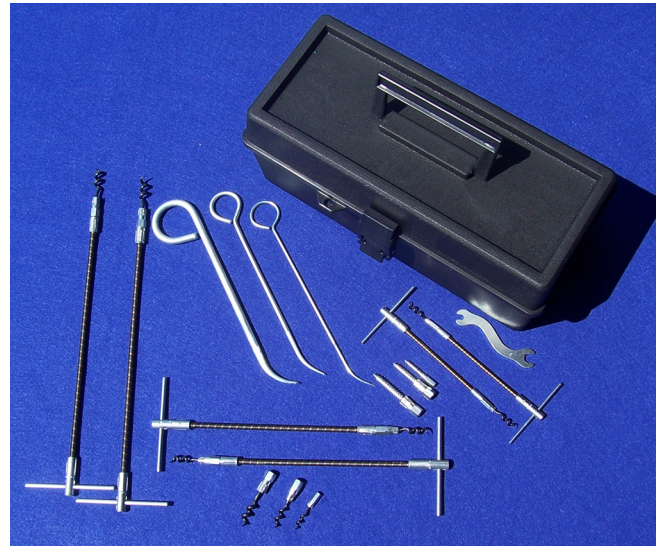

## REPLACEMENT CORKSCREW TIPS

- » C-1: No. 1 Corkscrew Tip
- » C-2: No. 2 Corkscrew Tip
- » C-3: No. 3 Corkscrew Tip



# Packing Tools

## SOLID SHAFT EXTRACTORS WITH NON-REPLACEABLE TIPS: SIZES SN1, SN2, SN3

- » SN1: Length 6", Shaft Diam 5/32
- » SN2: Length 10", Shaft Diam 1/4"
- » SN3: Length 14", Shaft Diam 1/4"

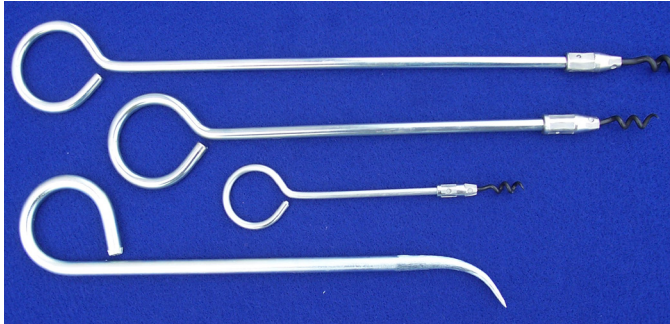

## GUILLOTINE PACKING CUTTER

Easily cuts all packing including KEVLAR® fiber, copper sheathhead, and wire core packing to 1" Diameter at 45° or butt angles. 4" max shaft size direct-reading Diameter/circumference scales eliminate expensive time and material waste from costly trial-and-error fitting. Complete with mounting screws, wrenches, stop blocks for 45° and butt cutting, and a vernier caliper for accurate shaft and stuffing box measurement. Heat-treated spare tool steel blades are available.

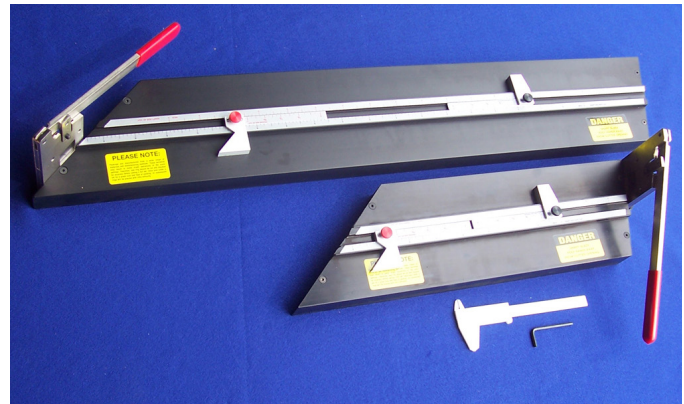
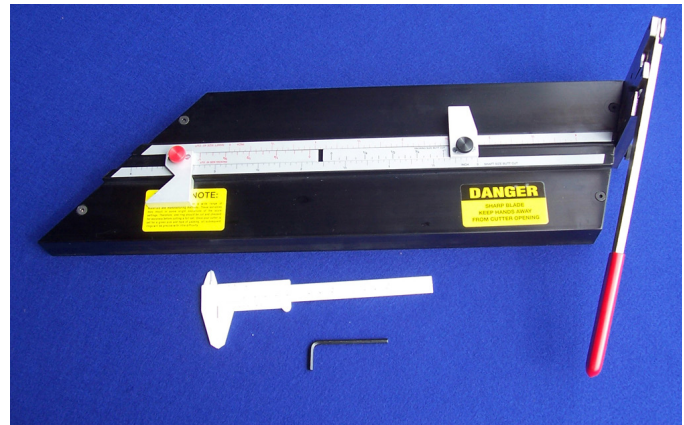

# Lubricating Compounds

## **LUBALL**

- » Petroleum-based grease with molybdenum disulfide
- » No graphite or fillers, completely waterproof
- » Rated to 500°F

## **NO. 2 LUBRICATING COMPOUND**

- » Graphite-filled, mineral oil base (45% graphite by weight)
- » Although rated to 500°F, it will start to flow somewhat between 300°F and 400°F

## **START-UP™ RUN-IN LUBRICANT**

- » White, water based lubricant for pumps
- » Non-staining, non-contaminating and harmless to skin, it contains no graphite
- » Apply START-UP lubricant to packing rings for easier installation and run-in
- » Rings of packing will then slide on the shaft without resistance
- » In service START-UP lubricant leaves no residue to collect between the rings so service life is extended
- » Removal of old packing becomes easier

# Style Index

Style	Material Classification	Lubrication	Construction	Rotary	Service Recip	Valve
18	Flax roving	Petrolatum & paraffin	Square braid	X	X	
90	Flax roving	Marine & petro wax/graphite	Square braid	X	X	
98	Carbon filament	Graphite dispersion	LATTICE BRAID®	X	X	X
98-PBI	Carbon filament	Graphite dispersion	LATTICE BRAID®	X	X	
105 (CARBAE™)	Carbon filament	PTFE & snow-white petrolatum	LATTICE BRAID®	X		
108 (CARBAE™)	Carbon filament	Graphite dispersion	LATTICE BRAID®	X	X	X
127-AFP	INCONEL <sup>1</sup> wire-reinforced spun carbon over homogeneous core	Graphite	Braid over core			X
G-200	Graphite filament	Graphite dispersion	LATTICE BRAID®	X		
G-700 <sup>2</sup>	Graphite filament	Graphite	LATTICE BRAID®			X
740	Flax roving	Petrolatum & marine wax	LATTICE BRAID®	X	X	
745	Flax roving	Petrolatum, marine wax, & graphite	LATTICE BRAID®	X	X	
1298	INCONEL wire-reinforced high-performance fiber over carbon yarn core	Graphite & tungsten disulfide	Braid over core			X
1300-E	Flexible graphite	None	LATTICE BRAID®	X		X
1303-FEP	INCONEL filament-reinforced flexible graphite	Graphite dispersion	Square braid			X
1306	Flexible graphite with carbon yarn corners	Graphite	LATTICE BRAID®	X		
1333-G	Graphite filament-reinforced flexible graphite	Graphite	Square braid	X		X
1812	Spun NOMEX <sup>3</sup> / synthetic	PTFE & snow-white petrolatum	LATTICE BRAID®	X	X	
1850	KYNOL <sup>4</sup>	PTFE & snow-white petrolatum	LATTICE BRAID®	X	X	
1925	Fiber-infused PTFE	PTFE suspensoid and snow-white petrolatum	LATTICE BRAID®	X		
1947	NOMEX <sup>3</sup> fiber	PTFE & silicone	LATTICE BRAID®	X		
1965	Fiber-infused PTFE	Graphite	LATTICE BRAID®	X		
5000	Carbon filament	PTFE & snow-white petrolatum	LATTICE BRAID®	X	X	
5000-PBI	Carbon filament w/ high-performance fiber corners	PTFE & snow-white petrolatum	LATTICE BRAID®	X	X	
5100	GFO <sup>5</sup>	Silicone	LATTICE BRAID®	X		X
5200	Aramid filament	PTFE dispersion	LATTICE BRAID®	X	X	
5413	Flax roving	PTFE & snow-white petrolatum	Square braid	X	X	
5450	Fiberglass	None—Graphite on request	LATTICE BRAID®			
5481	Fiberglass	None—Graphite on request	Round braid			

1. INCONEL is a registered trademark of Inco Alloys International, Inc.
2. To be used as end ring material only with GRAPH-LOCK® center rings.
3. NOMEX is a registered trademark of DuPont.
4. KYNOL is a trademark of American Kynol, Inc.
5. GFO is a trademark of WL Gore.

\* 0-14 except strong oxidizers

# Style Index cont'd

Style	Temperature		Pressure (psi)		Pressure (bar)		Shaft Speed		pH
	Fahrenheit	Centigrade	Rotary	Valve	Rotary	Valve	fpm	m/s	
18	To +220°	To +105°	150		10		1,200	6	5-9
90	To +220°	To +105°	300		20		1,200	6	5-9
98	-328° to +850° atm +1,200° steam	-200° to +455° atm +650° steam	500	2,500	35	173	4,000	20	0-14*
98-PBI	To +650° atm	To +345° atm	500		35		4,000	20	1-12
105 (CARBAE™)	-328° to +600° atm	-200° to +316° atm	500		35		3,000	15	0-14*
108 (CARBAE™)	-328° to +850° atm +1,200° steam	-200° to +455° atm +650° steam	500	2,500	35	173	4,000	20	0-14*
127-AFP	+850° atm +1,200° steam	+455° atm +650° steam		1,200		82			1-12
G-200	-328° to +850° atm +1,200° steam	-200° to +455° atm +650° steam	500		35		4,000	20	0-14*
G-700 <sup>2</sup>	To +850° atm +1,200° steam	To +455° atm +650° steam		4,000		275			0-14*
740	To +220°	To +105°	150		10		1,200	6	5-9
745	To +220°	To +105°	250		17		1,200	6	5-9
1298	To +850° atm +1,200° steam	To +455° atm +650° steam		4,500		310			1-12
1300-E	-328° to +850° atm +1,200° steam	-200° to +455° atm +650° steam	500	3,000	35	200	4,000	20	0-14*
1303-FEP	-328° to +850° atm +1,200° steam	-200° to +455° atm +650° steam		4,500		310			0-14*
1306	-328° to 850° atm 1,200° steam	-200° to 455° atm 650° steam	500		35		4,000	20	0-14*
1333-G	-328° to +850° atm +1,200° steam	-200° to +455° atm +650° steam	600	4,000	41	275	4,800	23	0-14*
1812	-170° to +500°	-110° to +260°	300		20		2,000	10	1-12
1850	-170° to +500°	-110° to +260°	500		35		2,000	10	1-13
1925	-450° to +500°	-270° to +260°	300		20		2,500	12	1-13
1947	To +500°	To +290°	300		20		2,500	12	
1965	-450° to +500°	-270° to +260°	600		41		2,500	12	1-13
5000	-328° to +600°	-200° to +315°	300		35		3,000	15	0-14*
5000-PBI	-328° to +600°	-200° to +315°	500		35		3,000	15	1-12
5100	-200° to +550°	-130° to +288°	300	2,000	20	138	4,000	20	0-14*
5200	-420° to +500°	-250° to +260°	500		35		2,500	12	2-12
5413	To +250°	To +120°	200		14		1,200	6	5-9
5450	To +1000°	To +540°		10		1			2-11
5481	To +1000°	To +540°		10		1			2-11

**WARNING:**

Properties/applications shown throughout this brochure are typical. Your specific application should not be undertaken without independent study and evaluation for suitability. For specific application recommendations consult Garlock. Failure to select the proper sealing products could result in property damage and/or serious personal injury.

Performance data published in this brochure has been developed from field testing, customer field reports and/or in-house testing.

While the utmost care has been used in compiling this brochure, we assume no responsibility for errors. Specifications subject to change without notice. This edition cancels all previous issues. Subject to change without notice.

GARLOCK is a registered trademark for packings, seals, gaskets, and other products of Garlock.

# Style Index cont'd

Style	Material Classification	Lubrication	Construction	Rotary	Service Recip	Valve
5882	Expanded PTFE/carbon filament	PTFE suspensoid	Braid over braid			X
5888	PTFE filament	PTFE suspensoid	LATTICE BRAID®	X	X	X
5889	PTFE filament	PTFE dispersion & silicone	LATTICE BRAID®	X		
5898	PTFE filament	PTFE dispersion	LATTICE BRAID®		X	X
5904	PTFE filament—FDA	PTFE dispersion/mineral oil	LATTICE BRAID®	X		
8091 HYDRA-JUST™	Dynamic Rotary Sealing Solution	N/A	GYLON® & Graphite Braid with Graphite Cup & Cone	X		
8093 DSA	Flexible graphite	N/A	Die-formed sets	X		
8094 DSA	Flexible graphite / Model 26	N/A	Die-formed sets	X		
8909	Spun synthetic	Graphite & petrolatum	Square braid	X		
8913	Spun synthetic	Graphite & petrolatum	LATTICE BRAID®	X		
8921-K	Spun synthetic—aramid filament corners	PTFE suspensoid & snow-white petrolatum	LATTICE BRAID®	X	X	X
8922	Spun synthetic	PTFE suspensoid & snow-white petrolatum	LATTICE BRAID®	X	X	X
8922-PBI	Spun synthetic / PBI corners	PTFE suspensoid & snow-white petrolatum	LATTICE BRAID®	X	X	
9000 EVSP	Flexible graphite	N/A	Die-formed sets			X
QUICKSET® 9001	Flexible graphite	N/A	Die-formed sets			X
F1	INCONEL <sup>3</sup> wire-reinforced spun carbon over homogeneous core	Graphite & zinc	Die-formed sets		Soot blower	
F3	INCONEL wire-reinforced PBI <sup>1</sup> over carbon yarn core	Graphite & tungsten disulfide	Die-formed sets		Soot blower	
F5	INCONEL wire-reinforced spun flexible graphite	Graphite dispersion	Die-formed sets		Soot blower	
GRAPH-LOCK®	Flexible graphite	N/A	Die-formed sets, tape	X		X
PM <sup>†</sup> -1	Spun synthetic	PTFE suspensoid & snow-white petrolatum	LATTICE BRAID®	X		
PM-2	Spun synthetic	Petroleum oils & graphite	LATTICE BRAID®	X		
PM-3	Spun synthetic	Petroleum oils & graphite	Square braid	X		
PM-5	Aramid filament	Silicone	LATTICE BRAID®	X	X	
PM-6	Expanded PTFE/graphite	Silicone	LATTICE BRAID®	X		
PM-6K	Expanded PTFE filament—aramid filament corners	Silicone	LATTICE BRAID®	X	X	
PM-7	PTFE filament	PTFE suspensoid	LATTICE BRAID®	X	X	X
PM-8	PTFE filament	Silicone	LATTICE BRAID®	X		

1. INCONEL is a registered trademark of Inco Alloys International, Inc.  
 2. To be used as end ring material only with GRAPH-LOCK® center rings.  
 3. NOMEX is a registered trademark of DuPont  
 4. KYNOL is a trademark of American Kynol, Inc.

\* 0-14 except strong oxidizers  
 \*\* Should not be used in chlorine  
 \*\*\* Pressure and shaft speeds controlled by types of braid used in conjunction with the GRAPH-LOCK® product  
 † PM = PACKMASTER®

# Style Index cont'd

Style	Temperature		Pressure (psi)		Pressure (bar)		Shaft Speed		pH
	Fahrenheit	Centigrade	Rotary	Valve	Rotary	Valve	fpm	m/s	
5882	-200° to 550°	-130° to 288°		3500		242			0-14
5888	-450° to +500°	-270° to +260°	300	2,000	20	138	1,000	5	0-14
5889	-450° to +500°	-270° to +260°	300		20		1,500	8	0-14**
5898	-450° to +500°	-270° to +260°	300	2,000	20	138	1,000	5	0-14
5904	-450° to +500°	-270° to +260°	500		20		1,500	8	0-14
8091 HYDRA-JUST™	To 500°F	200°C	500		35		4,000	20	0-14
8093 DSA	To 500°F	To +260°	300		35		4,000	20	0-14*
8094 DSA	To +200°	To +93°	300		20		4,000	20	2-12
8909	-170° to +500°	-110° to +260°	300		20		1,500	8	4-10
8913	-170° to +500°	-110° to +260°	500		20		1,500	8	4-10
8921-K	-170° to +500°	-110° to +288°	500	2,500	35	173	2,250	11	0-12
8922	-170° to +500°	-110° to +288°	500	2,500	35	173	2,250	12	0-12
8922-PBI	-170° to +500°	-110° to +288°			35		2,250	11	1-12
9000 EVSP	-328° to +850° atm +1,200° steam	-200° to +455° atm +650° steam		10,000		690			0-14*
QUICKSET® 9001	-328° to +850° atm +1,200° steam	-200° to +455° atm +650° steam		10,000		690			0-14*
F1	To +650° atm +1,200° steam	To +345° atmosphere +650° steam							1-12
F3	To +850° atm +1,200° steam	To +455° atmosphere +650° steam							1-12
F5	To +850° atm +1,200° steam	To +455° atmosphere +650° steam							0-14
GRAPH-LOCK®	-328° to +850° atm +1,200° steam	-200° to +455° atm +650° steam	***	***	***	***	***	***	0-14*
PM <sup>+</sup> -1	170° to +500°	-110° to +260°	300		20		1,500	8	4-10
PM-2	170° to +500°	-110° to +260°	300		20		1,500	8	4-10
PM-3	170° to +500°	-110° to +260°	200		14		1,000	5	4-10
PM-5	-420° to +500°	-250° to +260°	500		35		2,500	12	2-12
PM-6	-200° to +550°	-130° to +288°	300		20		3,000	15	0-14**
PM-6K	-200° to +550°	-130° to +288°	500		35		1,900	10	3-12
PM-7	-450° to 500°	-270° to +260°	300	2,000	20	138	1,000	5	0-14
PM-8	-450° to 500°	-270° to +260°	300		20		1,500	8	0-14**

**WARNING:**  
Properties/applications shown throughout this brochure are typical. Your specific application should not be undertaken without independent study and evaluation for suitability. For specific application recommendations consult Garlock. Failure to select the proper sealing products could result in property damage and/or serious personal injury.

Performance data published in this brochure has been developed from field testing, customer field reports and/or in-house testing.

While the utmost care has been used in compiling this brochure, we assume no responsibility for errors. Specifications subject to change without notice. This edition cancels all previous issues. Subject to change without notice.

GARLOCK is a registered trademark for packings, seals, gaskets, and other products of Garlock.

# Packing Materials

### ARAMID

These fibers are aromatic polyamides that were given the generic name “aramid.” With excellent resistance to high temperatures and exceptional tensile strength, aramid filaments are considered to be stronger, pound for pound, than steel. Garlock utilizes a variety of these fibers including spun and filament versions. Filament yarns are added to the corners of pump packings for greater resistance to abrasive media.

### CARBON/GRAPHITE FILAMENT PACKINGS

Garlock carbon fiber products are made from carbon yarns having a 95% minimum carbon assay. Premium products (Styles 98, 98-VC and 5000) use exclusive staple fiber yarn, that allows the packing to conform to shape and fit better, compared to continuous carbon fiber packing. This advantage improves sealing while maintaining low friction coefficients resulting in less shaft wear, greater packing longevity and lower maintenance cost. Garlock carbon fiber packing offer more value per weight than other common carbon packing.

Garlock graphite filament products are braided from high-purity graphite filaments with a minimum carbon assay of 99%. They have excellent chemical resistance, are thermally conductive and can be used in extreme temperature and pressure conditions.

### FIBERGLASS

Glass fibers exhibit superior thermal properties, dimensional stability and tensile strength. Glass fibers will not burn, and they dissipate heat more rapidly than organic fibers. The glass fibers most commonly used in compression packings are “E” grade (electrical) and “S” grade (strength). Common solvents, oils, petroleum distillates, bleaches and most organic chemicals do not affect fiberglass.

### FLAX

Garlock carefully selects quality long-fiber roving yarns, braids them, and then thoroughly impregnates them with the required lubricating agents. They are designed for optimum service in waste and dilute aqueous solutions up to +250°F (+121°C) at low to medium pressures. Industries such as mining, milling, steel, waste/water treatment, marine, and pulp and paper regularly specify these packings for their operations.

### GRAPH-LOCK® PRODUCTS

Made of extremely pure graphite, Garlock GRAPH-LOCK® packing products offer unmatched service in industrial environments where searing temperatures and crushing pressures cause constant failure of conventional packings.

### FLEXIBLE GRAPHITE TAPE PRODUCTS

GRAPH-LOCK® is self-lubricating, dimensionally stable, impervious to gases and fluids, and corrosion-resistant. GRAPH-LOCK® products offer excellent sealing capabilities under extreme conditions for longer equipment life and less maintenance. It is available in tape and die-formed rings from Garlock Compression Packing and in sheet form from Garlock Sheet Products.

Garlock Compression Packing offers two purity levels of our GRAPH-LOCK® products—commercial grade of 95% and nuclear grade of 99.5%. The nuclear grade material meets General Electric Spec. D50YP12, Rev. 2 dated Oct. 1992; MIL-P-24503B (SH); and can be certified for oxygen service.

### FLEXIBLE GRAPHITE BRAIDED PRODUCTS

Garlock offers a variety of high-purity braided flexible GRAPH-LOCK® products as well. We offer a plain braided graphite version (1300-E), INCONEL\* wire-reinforced versions (1303-FEP, 1398, 1399) and a graphite filament-reinforced version (1333-G).

### MILL-RIGHT® PRODUCTS

The experience gained over 100 years as a manufacturer has enabled Garlock to develop “Tough Technology” for the MILL-RIGHT® family of packings. Fiber-infused technology starts with yarns produced at our own facility. With the addition of an exclusive blocking and lubricating system, Garlock non-contaminating packings can resist abrasion without being abrasive to equipment and perform successfully throughout a broad range of industries and applications.

\* INCONEL is a registered trademark of Inco Alloys International, Inc.

# Packing Materials

## PBI

PBI is an acronym for the term “polybenzimidazole”, a high performance organic fiber. PBI fibers maintain dimensional stability at high temperatures and are compatible in a wide range of chemicals and solvents. Garlock incorporates wire-reinforced PBI yarns in valve stem packings as well as adding spun filament yarns to the corners of pump packings for added strength and abrasion resistance.

## PTFE PACKINGS

Garlock starts with the advantage of PTFE—excellent chemical resistance, a wide temperature range, flexibility with toughness—and combines them with the superior LATTICE BRAID® construction to form adaptable, effective packings. High in quality and consistently uniform, they are used extensively in the food processing, chemical, agricultural and petroleum processing industries.

## SYNTHEPAK® PRODUCTS

SYNTHEPAK® packings are a family of remarkable spun synthetic fiber packings created and developed by Garlock for low-cost general industrial service. Since they undergo the same braiding and treatment process as asbestos packings, SYNTHEPAK® packings make an excellent replacement for asbestos. This extremely adaptable fiber has proved superior to many types of conventional packings.

## XPG

The expanded PTFE/Graphite (XPG) yarn system is a unique blend of expanded PTFE filament with a blend of micronized graphite powder. The yarn utilizes a high temperature silicone oil lubricant. It can be used through an extremely wide range of applications including acids, alkalies, aromatic and aliphatic solvents, alcohols, esters, petroleum and synthetic oils, steam, water and aqueous solutions, and air and dry industrial gases.

XPG features good thermal conductivity, speed capability, chemical resistance, low coefficient of friction and low coefficient of thermal expansion, making it excellent for use in pumps, mixers and agitators.

### WARNING:

Properties/applications shown throughout this brochure are typical. Your specific application should not be undertaken without independent study and evaluation for suitability. For specific application recommendations consult Garlock. Failure to select the proper sealing products could result in property damage and/or serious personal injury.

Performance data published in this brochure has been developed from field testing, customer field reports and/or in-house testing.

While the utmost care has been used in compiling this brochure, we assume no responsibility for errors. Specifications subject to change without notice. This edition cancels all previous issues. Subject to change without notice.

GARLOCK is a registered trademark for packings, seals, gaskets, and other products of Garlock.

## Construction

Compression packings are made in a variety of shapes, sizes and constructions, from a wide range of materials. The following describes the most commonly-used constructions, and the advantages of each.

### BRAID-OVER-BRAID (FIGURE 1)

Round braiding machines braid tubular jackets using yarns, rovings, ribbons and various other materials, either alone or in combination. Size is obtained by braiding jackets one over the other (braid-over-braid). Finished packings can be supplied in round, square or rectangular cross section. Braid-over-braid packings, also known as round braid or multiple braid packings, are relatively dense and are recommended for high-pressure, slow-speed applications such as valve stems, expansion joints, groove gasketing, etc.

### BRAID-OVER-CORE (FIGURE 2)

Finished product is produced by round braiding one or more jackets of yarns, rovings, ribbons or other forms of various materials over a core, which may be extruded, twisted, wrapped or knitted. This construction allows for a wide range of densities and different cross sectional shapes.

### SQUARE BRAID (FIGURE 3)

Yarns, rovings, ribbons and other various materials, either alone or in combination, are processed on equipment where strands pass over and under strands running in the same direction. Resulting packings are usually supplied in square cross section, but rectangular sizes can also be braided by this method. The packing is usually soft and can carry a large percentage of lubricant. Square braided packings are easy on equipment and are generally used for high-speed rotary service at relatively low pressure. The packing's softness makes it ideal for old or worn equipment.

### LATTICE BRAID® (FIGURE 4)

Yarns, rovings, ribbons and other forms of various materials, either alone or in combination, are processed on equipment where the strands crisscross from the surface diagonally through the body of the packing. Each strand is strongly locked by other strands to form a solid integral structure that cannot easily ravel or come apart in service. There are no jackets to wear through, and no plaits to come loose. LATTICE BRAID® packing has a more even distribution of yarn density throughout and has the potential for improved lubricant retention. The finished packing is relatively dense, but flexible.

LATTICE BRAID® packings are suitable for applications on both reciprocating and centrifugal pumps, agitators, valves, expansion joints and in grooves.



Figure 1



Figure 2

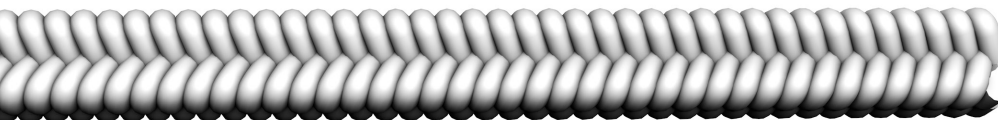

Figure 3

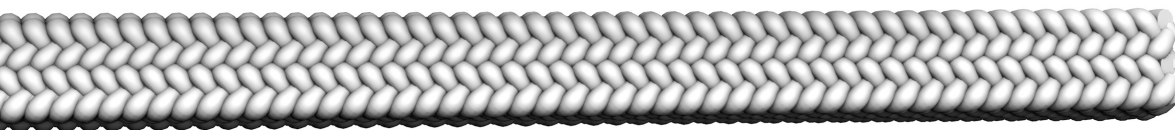

Figure 4

# Construction

## DIE-FORMED

Many compression packing materials can be supplied in a pre-compressed ring form, which provides controlled density and size.

## MANDREL CUT

Rings formed by wrapping braided stock of the required cross section on a mandrel or shaft with a Diameter equal to the desired I.D.

## GRAPHITE TAPE

Flexible graphite tape (ribbon) is manufactured by exfoliating (expanding) and then compressing natural graphite flakes to a specific density. Graphite has almost universal chemical inertness and is naturally lubricious, compactible and resilient, as well as nuclear radiation resistant.

Flexible graphite tape can be die-molded or compressed to form endless true labyrinth rings. Graphite tape packings have a low coefficient of friction, a pH range of 0-14 and are noted for their excellent thermal properties enabling them to be used in applications to 5500°F (3000°C) in non-oxidizing atmospheres. Due to their temperature resistance and density, they make ideal valve packings in steam, VOC, hydrocarbons or chemical applications when used in combination with braided end rings such as Styles 1303-FEP, 98 or G-700.

## LUBRICANTS

Lubricants are usually added to compression packings when the packings are to be used on rotary equipment where frictional heat is generated. The lubricants provide a resiliency that allows the packing to deform and recover under slight mechanical deficiencies such as shaft deflection. They may also provide interfiber lubricity that reduces frictional heat.

## BLOCKING AGENTS

Lubricants that act as a fluid barrier by closing the voids that are present in braided materials to prevent leakage through the cross section of the packing.

## SINGLE END COATING

A proprietary Garlock process that coats each yarn used in packing prior to the braiding process. This provides a more consistent coating of packing materials for better sealing.

# Material Selection

The proper selection of packing materials is dependent on the operating conditions of the equipment. Six parameters of the equipment must be determined before a proper packing recommendation can be made. The acronym "STAMPS" is commonly used to designate these parameters:

- S = Size — cross section
- T = Temperature — of media being sealed
- A = Application — type of equipment (i.e., pumps, valves, mixers, etc.)
- M = Media — material being sealed
- P = Pressure — of media being sealed
- S = Speed — shaft speed in fpm (pumps only)

# Equipment Condition

No matter what type of equipment you are trying to seal, the condition of the equipment is critical to the success of the packing. Garlock recommends:

## VALVES

- » Longitudinal scores on the valve stem are not to exceed 1/32" depth and/or a depth-to-width ratio greater than 1.00.
- » Stem finish no greater than 32 (micro inches) AARH.
- » Stuffing box finish is recommended to be 62 (micro inches) AARH.
- » Valve stem warpage / runout must be checked and found not to exceed:

Stem Diameter	Runout (TIR / ft)
Up to and including 1.500" (38.1 mm)	±0.010"
1.501" to 3.000" (38.1 mm to 76.2 mm)	±0.020"
3.001" (76.2 mm) and above	±0.040"

## PUMPS

- » Runout: TIR (Total Indicator Runout) not to exceed 0.005".
- » Longitudinal scores: none should be present on pump shaft or sleeve.

Shaft Diameter	Recommended Cross Section (CS)	
	Inches	mm
5/8" to 1-1/8"	5/16"	(7.9)
Over 1-1/8" to 1-7/8"	3/8"	(9.5)
Over 1-7/8" to 3"	1/2"	(12.7)
Over 3" to 4-3/4"	5/8"	(15.8)
Over 4-3/4" to 12"	3/4"	(19.0)

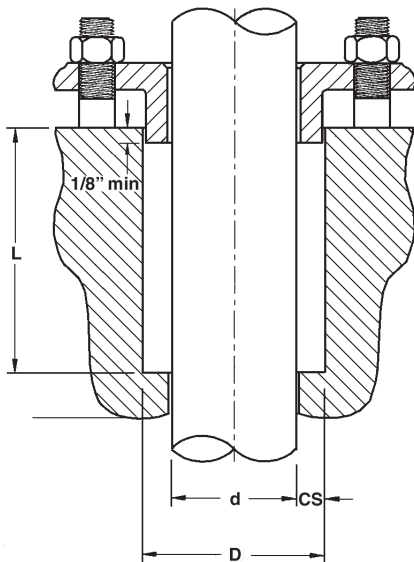

Stuffing box dimensions

- » The bottom of the gland follower should be flat. If box bottom is beveled, Garlock recommends the use of a system-compatible braided packing ring to be installed before the bushing.
- » Stuffing box should contain no burrs on the stem and/or box bore walls.

- $D = d + (2 \times CS)$
- » **Recommended box depth (L)** = (5.5 to 7.5) x CS
  - » **Recommended surface finishes:**
    - Stem / Sleeve: 16 to 32 (micro inches) AARH
    - Box Bore: 62 (micro inches) AARH

## WARNING:

Properties/applications shown throughout this brochure are typical. Your specific application should not be undertaken without independent study and evaluation for suitability. For specific application recommendations consult Garlock. Failure to select the proper sealing products could result in property damage and/or serious personal injury.

Performance data published in this brochure has been developed from field testing, customer field reports and/or in-house testing.

While the utmost care has been used in compiling this brochure, we assume no responsibility for errors. Specifications subject to change without notice. This edition cancels all previous issues. Subject to change without notice.

GARLOCK is a registered trademark for packings, seals, gaskets, and other products of Garlock.

# Installation Instructions

## VALVE STEM PACKING\*

1. Remove all of the old packing from the stuffing box. Clean box and stem thoroughly and examine stem for wear and scoring. Replace stem if wear is excessive. Recommended surface finishes are 32 (micro inches) AARH on the stem, and 62 (micro inches) AARH maximum on the box bore.
2. Measure and record stem Diameter, stuffing box bore and box depth. To determine the correct packing size, measure the Diameter of the stem (inside the stuffing box area if possible), and the Diameter of the stuffing box bore. Subtract the I.D. measurement from the O.D. measurement, and divide the difference by two. This is the required cross-sectional size.
3. Always cut the packing into individual rings. Never wind the packing into a coil in the stuffing box. Rings should be cut with a butt joint. Cut rings by using a spare stem, a mandrel with the same Diameter as the stem or a packing cutter. The illustration shows how to use a mandrel to cut packing.

Hold the packing tightly on the mandrel, but do not stretch excessively. Cut the ring and insert it into the stuffing box, making certain that it fits the packing space properly. Each additional ring can be cut in the same manner.

4. Install one ring at a time. Make sure it is clean, and has not picked up any dirt in handling. Seat each ring firmly, making sure it is fully seated before the next ring is installed. Joints of successive rings should be staggered and kept at least 90° apart. When enough rings have been individually seated so that the nose of the gland follower will reach them, individual tamping of the rings should be supplemented by the gland follower. Bring down the gland follower and apply load with the gland bolts.
5. After the last ring is installed, bring down the gland follower and apply 25% to 35% compression to the entire packing set. If possible, record the gland nut torque values and actuate the valve through five (5) complete cycles (ending with the stem in the down position). Retighten the gland bolt nuts to the previously recorded torque value after each full actuation.

Step 1

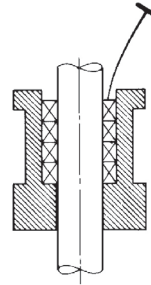

Step 2

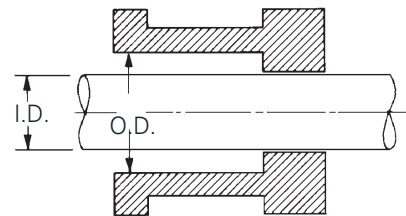
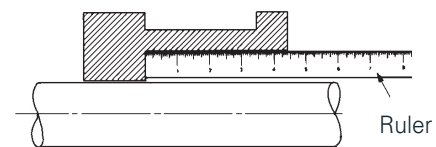

Step 3

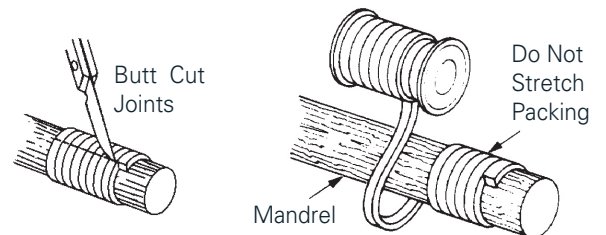

Steps 4 and 5

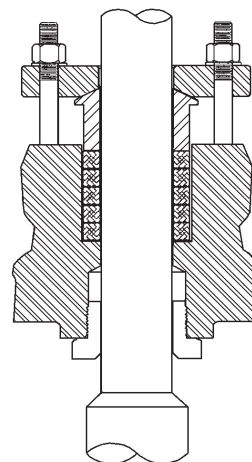

\* Valve stem packing general service installation instructions. For "low emissions" service, refer to the product specific instruction sheet or the LE Valve Stem Packing Owner's Manual.

# Installation Instructions

## PUMP PACKING\*

1. Remove all the old packing with packing hooks, being careful not to damage the shaft or sleeve. This means all rings, even the lantern ring and the rings below the lantern. Clean the stuffing box and examine the shaft and sleeve. Replace any worn parts that are scored or deeply grooved.
2. Measure and record shaft Diameter, stuffing box bore and box depth. To determine the correct packing size, measure the Diameter of the shaft and the stuffing box bore. Subtract the shaft Diameter from the bore Diameter and divide the difference by two. This is the required cross-sectional size.

3. Always cut the packing into individual rings. Never wind the packing into a coil in the stuffing box. Rings should be cut with a butt joint. Cut rings by using a mandrel with the same Diameter as the shaft in the stuffing box area. If there is no wear, rings can be cut on the shaft outside the stuffing box.

Hold the packing tightly on the mandrel, but do not stretch excessively. Cut the ring and insert it into the stuffing box, making certain that it fits the packing space properly. Each additional ring can be cut in the same manner.

4. Install one ring at a time. Make sure it is clean, and has not picked up any dirt in handling. Lubricate the I.D. of each ring lightly. Start one end and then the other, butted closely. Work around circumference from either or both directions. Joints of successive rings should be staggered and kept at least 90° apart. Each individual ring should be firmly seated with a tamping tool. When enough rings have been individually seated so that the nose of the gland follower will reach them, individual tamping should be supplemented by the gland.
5. If a lantern ring is provided, make sure the lantern ring is installed under the pipe tap hole.
6. After the last ring is installed, bring the follower down on the packing and finger-tighten the gland nuts. Do not jam the packing by excessive gland loading. Start pump, and tighten the bolts until leakage is decreased to a tolerable minimum. Make sure gland bolts are tightened evenly. Stopping leakage entirely at this point will cause the packing to burn up.
7. Allow packing to leak freely upon startup after repack. Gradually reducing leakage during the first hour of operation will result in a better seal over a longer period of time. Tighten the gland nuts one flat at a time until the desired leakage is obtained, and the pump is running cool.

Step 1

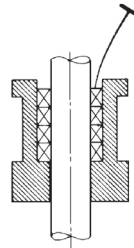

Step 2

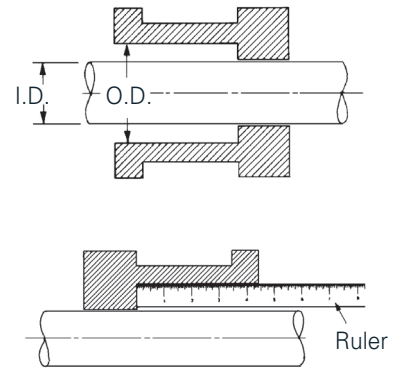

Step 3

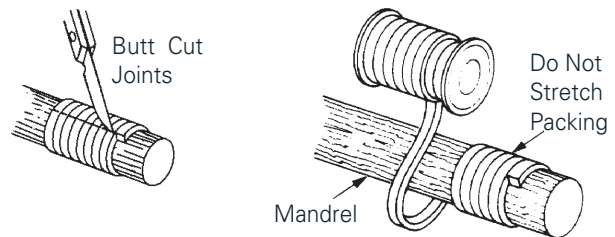

Steps 5 and 6

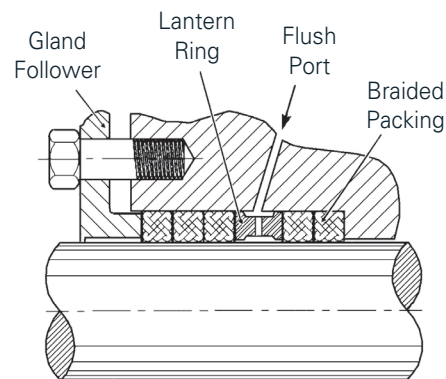

\* Pump packing general service installation instructions. For special products or services, refer to the product specific instruction sheet.

# Testing

## FUNCTIONAL TESTING

### Pump Test Fixtures

Garlock Compression Packing has three different pump test fixture designs used for evaluating pump packing set types and arrangements.

**Media:** Ambient temperature water  
 Note: The end suction pump system, due to the dynamics of a closed loop system, can produce water temperatures as high as 160°F (70°C).

**Abrasives:** Can be introduced into the end suction pump system

**Shaft Speeds:** From 367 fpm to 2,100 fpm (1.63 m/s to 9.33 m/s)

**Packing cross sections:** Typically 3/8" (9.5 mm) cross section, but modifications can be made to test up to 5/8" (15.8 mm) cross section.

**Stuffing box pressures:** 2 psi to 120 psi (0.1 to 8.3 bar)

Note: Pressures above 60 psi (4.1 bar) are achieved by throttling down the discharge flow in the end suction pump.

**Stuffing box depths:** 1.500" to 2.250" (38.1 mm to 57.2 mm)

## MATERIAL TESTING

### Material Testing Laboratory

The various testing capabilities are often used to check conformance to ISO material and processing specification requirements.

The Garlock Compression Packing facility has the capability to perform a range of in-house chemical and physical testing exercises. These tests are used to qualify or to check the conformance of incoming raw materials as an aid to in-process checks, or as a final qualification check to ensure that finished products meet the customer's agreed-upon specifications. Whenever possible and practical, Garlock performs its testing programs in conformance with existing ASTM procedures.

Examples of testing capabilities are:

- » Wet chemical testing
- » Weight loss determination
- » Exposure—radiation, argon, etc.
- » Yields—braid, ring
- » Tensile strength
- » Density determinations



Garlock Valve Test Fixture

### WARNING:

Properties/applications shown throughout this brochure are typical. Your specific application should not be undertaken without independent study and evaluation for suitability. For specific application recommendations consult Garlock. Failure to select the proper sealing products could result in property damage and/or serious personal injury.

Performance data published in this brochure has been developed from field testing, customer field reports and/or in-house testing.

While the utmost care has been used in compiling this brochure, we assume no responsibility for errors. Specifications subject to change without notice. This edition cancels all previous issues. Subject to change without notice.

GARLOCK is a registered trademark for packings, seals, gaskets, and other products of Garlock.

# Gasket Spacers

Gasket spacers are used in conjunction with braided packing rings to:

- » Close up the clearances around the inside Diameter of the packing set, keeping solid particles from progressing through the packing set along with the liquid leakage
- » Act as a throttle bushing and reduce the pressure on the outboard side of the spacer, in applications where the leakage rate is relatively high
- » Keep the packing from extruding beyond the stuffing box bottom, where there are excessive clearances between the I.D. of the stuffing box bottom and the shaft O.D. (This problem may occur through wear, corrosion, or simply the way a piece of equipment is manufactured)

In applications involving high stuffing box pressures (particularly reciprocating pumps) gasket spacers are also used to:

- » Reduce the amount of leakage that occurs through the body of the braid, by forcing leakage to the I.D. of the packing set and eliminating O.D. leakage
- » Keep the packing square, restrict packing movement, and prevent packing rollover and premature failure caused by excessive frictional forces

## STEALTH PACKING SET OPTION

- » Optimal dry running situation—eliminate flush and lantern ring
- » Combines Garlock Style 3530 GYLON® spacers with 1333-G cut rings
- » Contact Applications Engineering for details

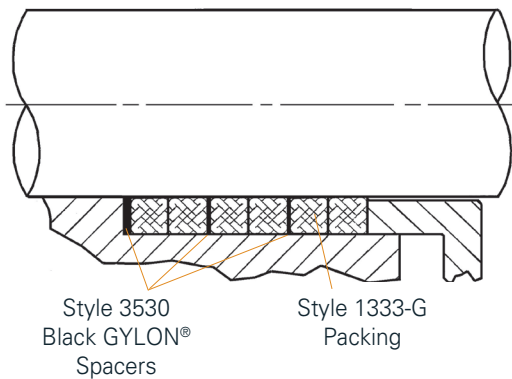

Stealth Packing Set Spacer and Ring Arrangement

# Gland Load\*

Garlock recommends using one of these two methods to determine the proper gland load on a valve packing set.

This method simply determines the distance the set should be compressed in order to achieve a seal. The recommended percent compression varies with packing style.

» 9000-EVSP Simplified	30% compression
QUICKSET® 9001	30% compression
» 70#/ft <sup>3</sup> density GRAPH-LOCK®	25% compression
70#/ft <sup>3</sup> density #98 sets	25% compression
» 90#/ft <sup>3</sup> density GRAPH-LOCK®	20% compression
90#/ft <sup>3</sup> density #98 sets	20% compression
» Garlock braided packing only	25% compression

In cases where the system pressure is very high (over 2,500 psi or 172 bar), higher compression may be required to achieve a seal.

This method determines a more precise gland load. The bolt torque depends upon packing size, gland bolt size, packing style system pressure, and the number of bolts. The gland studs and nuts must be in good condition, cleaned with a wire brush and well-lubricated with a suitable grease.

Use the following equation to determine the appropriate bolt torque:

$$\text{Bolt torque} = \frac{(\text{Bore dia.}^2 - \text{Stem dia.}^2) \times (\text{Gland bolt dia.}) \times (\text{Load factor})}{76.39 \times (\text{No. of bolts})}$$

Where: Bolt torque is in ft. lbs.  
Bore, stem, and bolt Diameters are in inches  
Load factor is in psi

The load factor is determined by the following:

- » For a 9000-EVSP Simplified set, a 9001 QUICKSET® or a Style #98 and GRAPH-LOCK® set:  
LF = 1.5 system pressure or 3,800 psi (whichever is greater)
- » When using any other Garlock packing:  
LF = 1.5 system pressure or 5,500 psi (whichever is greater)

\* General service gland load recommendation. For “low emissions” service, refer to the product specific instruction sheet or the LE Valve Stem Packing Owner’s Manual.

# pH Values

The scientific shorthand for indicating the level of acidity or alkalinity of a substance is the pH value. The scale is logarithmic, making lye, at 13, ten times as alkaline as ammonia at 12.

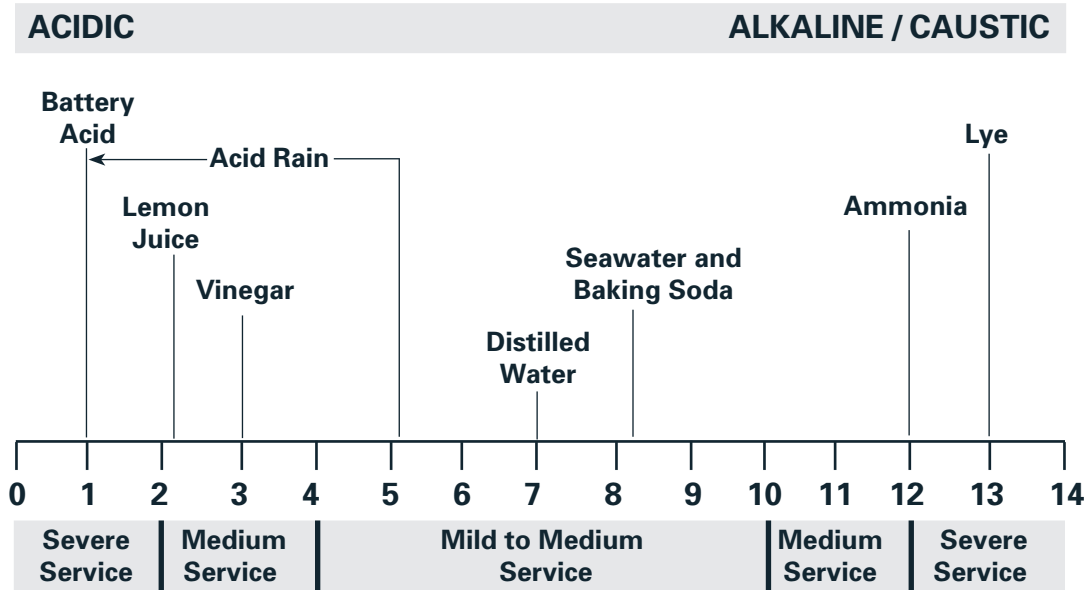

## Common Oxidizers

Oxidizers act as a catalyst and cause hydrocarbons to combine with oxygen and cause breakdown of the fiber. Here is a partial listing of the most commonly used strong oxidizers. (A complete listing is available from Garlock Applications Engineering.)

- Fluorine, used as an oxidizer or rocket fuel.
- Sulfur Trioxide, used to make sulfuric acid.
- Aqua Regia (nitric and hydrochloric acid), used to dissolve metals.
- Sodium Peroxide, used in dyeing, paper and oxygen generation.
- Oleum (fuming sulfuric), used in detergent and explosive manufacturing.
- Perchloric Acid, used in the manufacturing of explosives, esters and medicine.
- Sulfuric Acid, greater than 75% and over 250°F, the most widely-used industrial chemical.
- Chloric Acid, greater than 10% and over 200°F, ignites organic materials on contact.
- Ferric Chloride, greater than 50% and over 200°F, used for sewage treatment, photography, medicine, etching, feed additives and oxidizing disinfectant.
- Nitric Acid, used in fertilizer, explosives, etching, medicine, dyeing and drugs.
- Chlorous Acid, greater than 10% and over 200°F.
- Iodine, greater than 5% and over 200°F, used in soaps, medicine, some lubricants, dyes and salt.
- Hydrofluoric Acid, greater than 40% and over 200°F, used for pickling, purification, dissolving ores, cleaning castings, etching, cleaning stone and brick, and fermentation.
- Sodium Hypochlorite, greater than 5%, used in textiles, water purification and bleaching pulp and paper.
- Sodium Chlorate, greater than 5%, used as bleach for paper pulp, medicine and leather textiles.
- Calcium Chlorate, greater than 5%, used in pyrotechnics and photography.



# Ordering Information

## BRAIDED PACKING

### Sizes

Inches	mm	Inches	mm
1/8	3x3	-	12x12
-	4x4	1/2	12.7x12.7
3/16	5x5	9/16	14x14
-	6x6	5/8	16x16
1/4	6.5x6.5	11/16	18x18
5/16	8x8	3/4	19x19
3/8	9.5x9.5	13/16	20x20
-	10x10	7/8	22x22
7/16	11x11	1	25x25

Note: Additional cross-sections available on request.

## DIE-FORMED RINGS

Garlock can produce die-formed rings in more than 5,000 sizes. When placing your order, specify the I.D., the O.D., the ring/set height (and density if necessary).

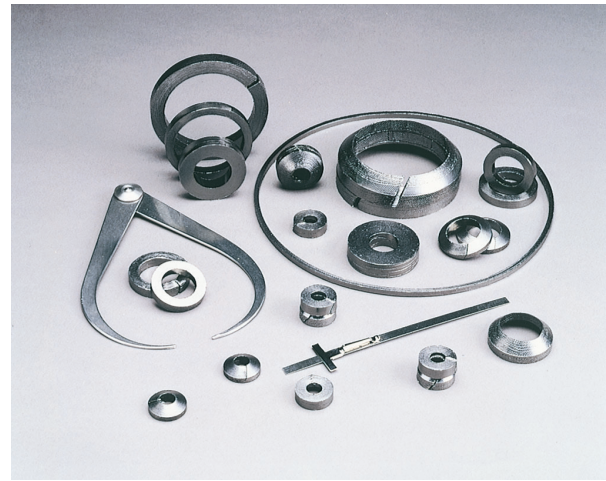

## RPM / FPM CONVERSION TABLE

		Shaft Rotary Speed (RPM)												
		100	300	500	1,000	1,500	1,750	2,000	2,500	3,000	3,600	4,000	4,500	5,000
Shaft Diameter (in)	0.500	13	39	65	131	196	229	262	327	393	471	524	589	654
	0.750	20	59	98	196	295	344	393	491	589	707	785	884	982
	1.000	26	79	131	262	393	458	524	654	785	942	1,047	1,178	1,309
	1.250	33	98	164	327	491	573	654	818	982	1,178	1,309	1,473	1,636
	1.500	39	118	196	393	589	687	785	982	1,178	1,414	1,571	1,767	1,963
	1.750	46	137	229	458	687	802	916	1,145	1,374	1,649	1,833	2,062	2,291
	2.000	52	157	262	524	785	916	1,047	1,309	1,571	1,885	2,094	2,356	2,618
	2.500	65	196	327	654	982	1,145	1,309	1,636	1,963	2,356	2,618	2,945	3,272
	3.000	79	236	393	785	1,178	1,374	1,571	1,963	2,356	2,827	3,142	3,534	3,927
	3.500	92	275	458	916	1,374	1,604	1,833	2,291	2,749	3,299	3,665	4,123	4,581
	4.000	105	314	524	1,047	1,571	1,833	2,094	2,618	3,142	3,770	4,189	4,712	5,236
	5.000	131	393	654	1,309	1,963	2,291	2,618	3,272	3,927	4,712	5,236	5,890	
	6.000	157	471	785	1,571	2,356	2,749	3,142	3,927	4,712	5,655			
	7.000	183	550	916	1,833	2,749	3,207	3,665	4,581	5,498				
	8.000	209	628	1,047	2,094	3,142	3,665	4,189	5,236					
9.000	236	707	1,178	2,356	3,534	4,123	4,712	5,890						
10.000	262	785	1,309	2,618	3,927	4,581	5,236							

# Compression Packing Application Data Form

Customer: \_\_\_\_\_  
\_\_\_\_\_  
\_\_\_\_\_  
Phone: \_\_\_\_\_  
Email: \_\_\_\_\_

Submitted by: \_\_\_\_\_  
\_\_\_\_\_  
Date: \_\_\_\_\_  
Fax: \_\_\_\_\_

### Service Conditions

Shaft speed: \_\_\_\_\_ rpm (or) \_\_\_\_\_ fpm  
Temperature: \_\_\_\_\_ °F (or) \_\_\_\_\_ °C  
Pressure: \_\_\_\_\_ psi (or) \_\_\_\_\_ bar  
Media (What is being sealed): \_\_\_\_\_ pH \_\_\_\_\_

### Equipment

Specify pump, valve, mixer, etc.: \_\_\_\_\_  
\_\_\_\_\_

Shaft dia.: \_\_\_\_\_ Bore dia.: \_\_\_\_\_ Box depth: \_\_\_\_\_

General condition of equipment & environment: \_\_\_\_\_  
\_\_\_\_\_  
\_\_\_\_\_

### Packing

What is presently being used? \_\_\_\_\_

Any problems with this material? \_\_\_\_\_  
\_\_\_\_\_  
\_\_\_\_\_

Comments: \_\_\_\_\_  
\_\_\_\_\_  
\_\_\_\_\_



---

**GARLOCK**  
an *EnPro* Industries family of companies

GST  
GPT  
Garlock Australia  
Garlock de Canada, LTD

Garlock China  
Garlock Singapore  
Garlock Germany  
Garlock India Private Limited

Garlock de Mexico, S.A. De C.V.  
Garlock New Zealand  
Garlock Great Britain Limited  
Garlock Middle East